

THIS DRAWING IS INTENDED ONLY AS A GUIDE AND NOT AS A REPLACEMENT FOR PROFESSIONALLY ENGINEERED PROJECT DRAWINGS. THIS CONCEPT SYSTEM DRAWING DOES NOT IMPLY COMPLIANCE WITH LOCAL BUILDING CODES. ACTUAL INSTALLATION MAY VARY DEPENDING ON INSTALLATION LOCATION AND PARAMETERS AND IT MUST BE DONE IN ACCORDANCE TO ALL LOCAL BUILDING CODES. VERIFY WITH LOCAL BUILDINGS OFFICIALS BEFORE COMMENCEMENT OF SYSTEM INSTALLATION. CHANGES OR MODIFICATIONS TO PIPING OR DESIGN IS NOT TO BE PERFORMED WITHOUT EXPRESSED WRITTEN PERMISSION BY NAVIEN, INC.

RECOMMENDED SYSTEM & HEADER PIPE SIZES – TOTAL BTU (>4 FT/SEC.)

- 1-1/2" – UP TO 301,000 BTU'S (1 BOILER)
- 2" – 399,000 BTU'S (1 BOILER)
- 2-1/2" – 601,000 TO 798,000 BTU'S (2 BOILERS)
- 3" – 903,000 TO 1,197,000 BTU'S (3 BOILERS)
- 4" – 1,204,000 TO 3,192,000 BTU'S (4 TO 8 BOILERS)

NFB-C UNIT CAN INTERNALLY CONTROL UP TO 3 ZONE CIRCULATORS/ZONE VALVES, WITHOUT A ZONE CONTROL PANEL INSTALLED. ANY ADDITIONAL ZONES SHALL REQUIRE A CIRC ZONE PANEL. REFER TO NAVIEN I & O MANUAL FOR ADDITIONAL INFORMATION.

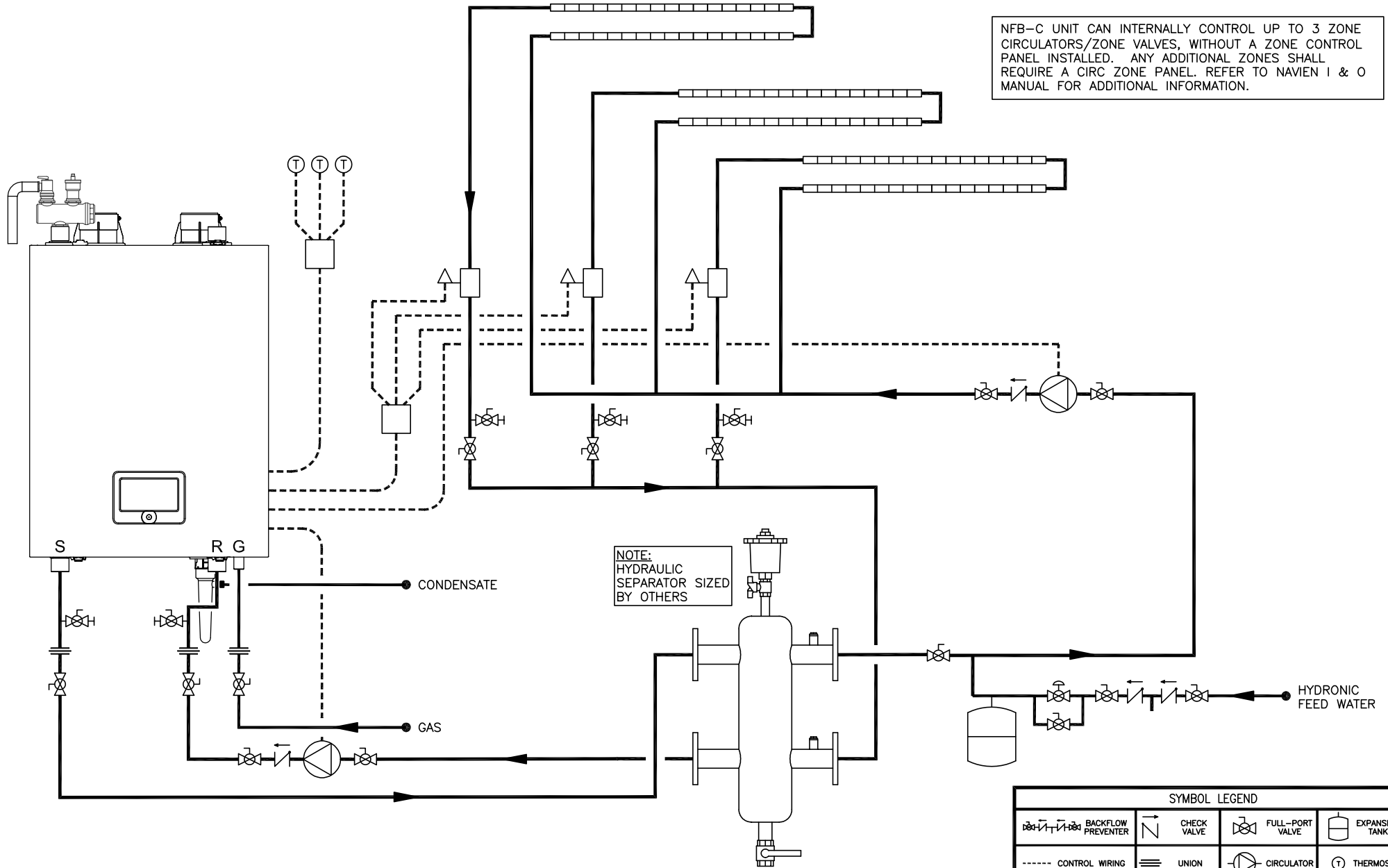

NOTE:
HYDRAULIC
SEPARATOR SIZED
BY OTHERS



20 GOODYEAR
IRVINE, CA 92618
800-519-8794
www.navienc.com

NFB-C SERIES BOILER

(1) NFB-C CONDENSING BOILER WITH
MULTIPLE ZONE VALVES WITH HYDRAULIC SEPARATOR
INCLUDES MODELS NFB-301C, 399C

DRAWN BY: S. STOEKE

NFB-C-1-3ZV-HS

JUNE 9, 2022

SYMBOL LEGEND			
	BACKFLOW PREVENTER		CHECK VALVE
	FULL-PORT VALVE		EXPANSION TANK
	CONTROL WIRING		CIRCULATOR
	THERMOSTAT		CONDENSATE TRAP
	UNION		AIR ELIMINATION
	COPPER BASEBOARD FIN TUBE		BOILER RELIEF VALVE
	AUTOMATIC AIR VENT		ZONE VALVE
	BALL DRAIN VALVE		PRESSURE REDUCING VALVE
	HYDRAULIC SEPARATOR		