

Installation and Operation Manual

NHB-H Condensing Boilers

Model | NHB-055H
NHB-080H
NHB-110H
NHB-150H



ALWAYS read and follow this manual completely before using the boiler. Save for future reference.

WARNING

If the information in these instructions is not followed exactly, a fire or explosion may result, causing property damage, personal injury, or death.

Do not store or use gasoline or other flammable vapors and liquids in the vicinity of this or any other appliance.

WHAT TO DO IF YOU SMELL GAS

- Do not try to light any appliance.
- Do not touch any electrical switch; do not use any phone in your building.
- Immediately call your gas supplier from a neighbor's phone. Follow the gas supplier's instructions.
- If you cannot reach your gas supplier, call the fire department.

Installation and service must be performed by a qualified installer, service agency or the gas supplier.

The installation must conform with local codes or, in the absence of local codes, the National Fuel Gas Code, ANSI Z223.1/NFPA 54 and/or CSA B149.1, Natural Gas and Propane Installation Code.

Contents

Important Safety Information	3	9. Installing a Common Vent System	77
1. About the Boiler	5	9.1 About the Common Vent System	77
1.1 Included Items	5	9.2 Navien Common Vent Collar Kit (Back-draft Damper)	82
1.2 Accessories	5	9.3 Starting the Common Vent System	83
1.3 Specifications	6	9.4 Connecting and Terminating the Vent Pipe	87
1.4 Components	8	9.5 Setting up the Common Vent System	90
1.5 Dimensions	10	9.6 Common Vent Termination Clearances	90
1.6 Rating Plate	11	9.7 Installing a Condensate Drain	92
2. Installing the Boiler	12	9.8 Maintenance	93
2.1 Choosing an Installation Location	12	10. Installation Checklist	94
2.2 Mounting the Boiler to the Wall	14	11. Operating the Boiler	97
3. Installing the System Piping	16	11.1 Operating the Boiler for the First Time	97
3.1 Installing a Space Heating System	16	11.2 Turning the Boiler On or Off	98
3.2 Connecting the Condensate Drain	23	11.3 Start-Up Wizard	99
3.3 Filling the System	26	11.4 Adjusting the System Temperatures	100
3.4 Testing the Water System	26	11.5 Resetting the Boiler	103
3.5 Considerations for System Applications	27	11.6 Accessing Basic Menu Items	103
3.6 Examples of Electrical Connections	34	11.7 Viewing Basic Information	103
4. Connecting the Gas Supply	46	11.8 Setting the Space Heating Operation	104
4.1 Gas Pipe Sizing Tables	49	11.9 Setting the DHW Operation (Indirect)	107
4.2 Measuring the Inlet Gas Pressure	50	11.10 Viewing Error History	108
5. Venting for Combustion Air	52	11.11 Viewing Other System Information	108
5.1 Venting the Boiler	53	11.12 Setting the Display Options	109
5.2 About the Vent Installation Detector	55	11.13 Accessing Advanced Menu Items	109
5.3 Selecting a Vent Type	57	11.14 Understanding Error Codes	119
5.4 Selecting Vent Pipe Materials	61	12. Appendixes	120
5.5 Measuring Vent Length	62	12.1 Gas & High Altitude Conversion	120
5.6 Terminating the Vent	63	12.2 Wiring Diagram	128
6. Setting the DIP Switches	67	12.3 Ladder Diagram	129
6.1 DIP Switch 1 (Set of 6 Switches)	67	12.4 Outdoor Temperature Sensor	130
6.2 Dip Switch 2 (Set of 8 Switches)	68	12.5 Outdoor Reset Control	130
7. Connecting the Power Supply	70	12.6 Component Assembly Diagrams and Parts Lists	132
8. Installing a Cascade System	72	12.7 Requirements for the State of Massachusetts	139
8.1 Connecting Water Supplies	72	13. LIMITED WARRANTY NAVIEN, INC.	140
8.2 Connecting the Communication Cables	76		

Important Safety Information



The following Safety Alert Symbols are used in this manual. They are used to alert you to potential personal injury hazards. Obey all safety messages that follow this symbol to avoid possible serious injury or death. This Safety Alert Symbol precedes any safety message about risk of personal injury. It may also be accompanied by one of the following signal words.

If the information in these instructions is not followed exactly, a fire or explosion may result, causing property damage, personal injury or death.

DANGER

Indicates a hazardous situation that if not avoided will result in death or serious injury.

WARNING

Indicates a hazardous situation that if not avoided could result in death or serious injury.

CAUTION

Indicates a potentially hazardous situation that if not avoided could result in minor or moderate injury.

NOTICE

Indicates information considered important but not hazard-related (such as property damage).

DANGER

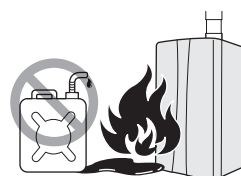

If you smell gas:

- Do not try to light any appliance.
- Do not touch any electrical switches or use landline phones.
- From a neighbor's phone, call your gas provider and follow their instructions.
- If you cannot reach your gas provider, call the fire department.
- Do not return to your home until authorized by your gas supplier or the fire department.

Do not use or store flammable products, such as gasoline, solvents, or adhesives in the same room or area as the boiler.

- The boiler has a main burner flame that can turn on at any time and can ignite flammable vapors. Vapors from flammable liquids can explode and catch fire, causing death or severe burns.
- Vapors cannot be seen and are heavier than air. They can travel long distances along the ground and can be carried from other rooms to the boiler's main burner flame by air current.
- Keep all flammable products far away from the boiler and store them in approved containers. Keep the containers closed tightly and out of the reach of children and pets.

Product Installation Information

Model	
Date Purchased	
Gas Type	
Serial Number	

WARNING

To prevent death, serious injury, or property damage:

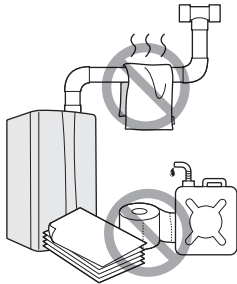

- **Do not store or use gasoline or other flammable liquids near this boiler.**
Doing so may result in fire or explosion.
- **Do not place combustibles, such as newspapers or laundry, near the boiler or venting system.**
Doing so may result in a fire.
- **Do not place or use hair sprays, spray paints, or any other compressed gases near the boiler or venting system, including the vent termination.**
Doing so may result in fire or explosion.
- **Do not operate the boiler with the front cover opened.**
Doing so may result in fire or carbon monoxide (CO) poisoning, which may result in property damage, personal injury, or death.
- **Do not operate this boiler without proper venting.**
Doing so may result in fire or carbon monoxide (CO) poisoning, which may result in property damage, personal injury, or death.
- **Do not touch the power cord or internal components of the boiler with wet hands.**
Doing so may result in electric shock.

California law requires the following Prop 65 warning to be provided:

WARNING

Cancer and Reproductive Harm -
www.P65Warnings.ca.gov.

WARNING









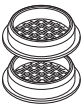
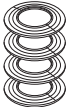

To prevent death, serious injury, or property damage:

- **Do not turn on the boiler unless the water and gas supplies are fully opened.**
Doing so may damage the boiler.
- **Do not use this boiler for anything other than its intended purpose, as described in this manual.**
- **Do not remove the front cover unless the power to the boiler is turned off or disconnected.**
Failure to do so may result in electric shock.
- **When servicing the controls, label all wires prior to disconnecting them.**
Failure to do so may result in wiring errors, which can lead to improper or dangerous operation. Verify proper operation after servicing.
- **Do not use unapproved replacement or accessory parts.**
Doing so may result in improper or dangerous operation and will void the manufacturer's warranty.
- **Do not place anything in or around the vent terminals, such as a clothes line, that could obstruct the air flow in or out of the boiler.**
- **This boiler has been approved for use in the USA and Canada only.**
Using the boiler in any other country will void the manufacturer's warranty.

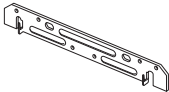
1. About the Boiler









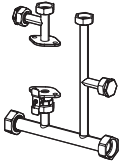
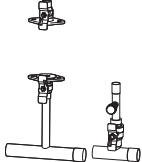
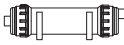

1.1 Included Items

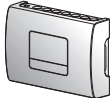
When you open the box, you will find the following items with the boiler. Check the box for each of the following items before installing the boiler.

	
Installation & Operation Manual, User's Information Manual	Quick Installation Manual
	
2 in Vent Termination Caps (x2)	2 in Wall Flanges (x4)
	
Spare Parts	Air Vent
	
Wall Mounting Bracket	Tapping Screws & Anchors (x4)
	
Pressure Relief Valve, Heating	Conversion Kit
	
Outdoor Temperature Sensor and Cable	Air Vent Bushing (3/4in to 1/2in)

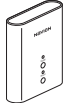
1.2 Accessories

The following optional accessories are available for the boiler.

	
STS Manifold System (for primary zone)	Navien Manifold System (for secondary zone)
	
Condensate Neutralizer Kit	Zone Controller (FMZ-20/30)
	
Zone Controller (FMZ-40/60)	System Supply/Return Temperature Sensors
	
Navi-Link (Wi-Fi Control System)	Ready-Link Rack
	
NaviLink Lite	NaviClean
	
Valve Kit	Universal Adapter Kit

1.3 Specifications

The following tables list the specifications for the boiler. Additional specifications for water, gas, electricity, and vent connections are provided in the Installation section.

Space Heating Specifications

Navien Condensing Boiler Space Heating Ratings							Other Specifications	
Model Number ¹	Heating Input (MBH)		Heating Capacity ² (MBH)	Net AHRI Rating Water ³ (MBH)	AFUE ² (%)	Water Pressure	Water Connection Size (Supply, Return)	
	Min	Max						
NHB-055H	8	55	51	44	95	12–30 psi	1 in NPT	
NHB-080H	8	80	73	64	95			
NHB-110H	10	110	101	88	95			
NHB-150H	10	150	136	118	95			

Note

1. Ratings are the same for natural gas models converted to propane use.
2. Based on U.S. Department of Energy (DOE) test procedures.
3. The net AHRI water ratings shown are based on a piping and pickup allowance of 1.15. Consult Navien before selecting a boiler for installations having unusual piping and pickup requirements, such as intermittent system operation, extensive piping system, etc.

General Specifications

Item		NHB-055H	NHB-080H	NHB-110H	NHB-150H
Dimensions		17.3 in (W) x 12.8 in (D) x 23.8 in (H)			
Weight		73 lb (33 kg)		80 lb (36 kg)	
Installation Type		Indoor Wall-Hung			
Venting Type		Forced Draft Direct Vent			
Ignition		Electronic Ignition			
Natural Gas Supply Pressure (from source)		3.5 in–10.5 in WC			
Propane Gas Supply Pressure (from source)		8.0 in–13.5 in WC			
Natural Gas Manifold Pressure		-0.11 in WC	-0.17 in WC	-0.26 in WC	-0.40 in WC
Propane Gas Manifold Pressure		-0.11 in WC	-0.17 in WC	-0.25 in WC	-0.41 in WC
Gas Connection Size		¾ in NPT			
Power Supply	Main Supply	120V AC, 60Hz			
	Maximum Power Consumption	Less than 15 amperes			
Materials	Casing	Cold-rolled carbon steel			
	Heat Exchangers	Primary and Secondary Heat Exchangers: Stainless Steel			
Venting	Exhaust	2 in or 3 in PVC, CPVC, approved polypropylene* 2 in or 3 in Special Gas Vent Type BH (Class III, A/B/C), Stainless Steel			
	Intake	2 in or 3 in PVC, CPVC, polypropylene 2 in or 3 in Special Gas Vent Type BH (Class III, A/B/C), Stainless Steel			
	Vent Clearance	0 in to combustibles			
Safety Devices		Flame Rod, APS, Ignition Operation Detector Water Temperature High Limit Switch, Exhaust Temperature High Limit Sensor, Water Pressure Sensor, Vent Installation Detector (VID)			

* For more information about the approved vent materials, refer to “5.4 Selecting Vent Pipe Materials” on page 61.

Temperature Setting Range

Item		Temperature Setting Range	Remarks
Space Heating	Supply	77–185°F (25-85°C)	Actual supply and return temperatures vary depending on the selected outdoor reset curve.
	Return	68–158°F (20-70°C)	

Note For more information about the space heating temperature setting range, refer to “11.8 Setting the Space Heating Operation” on page 104.

1.4 Components

The following diagram shows the key components of the boiler. Component assembly diagrams and particular parts lists are included in the Appendixes.

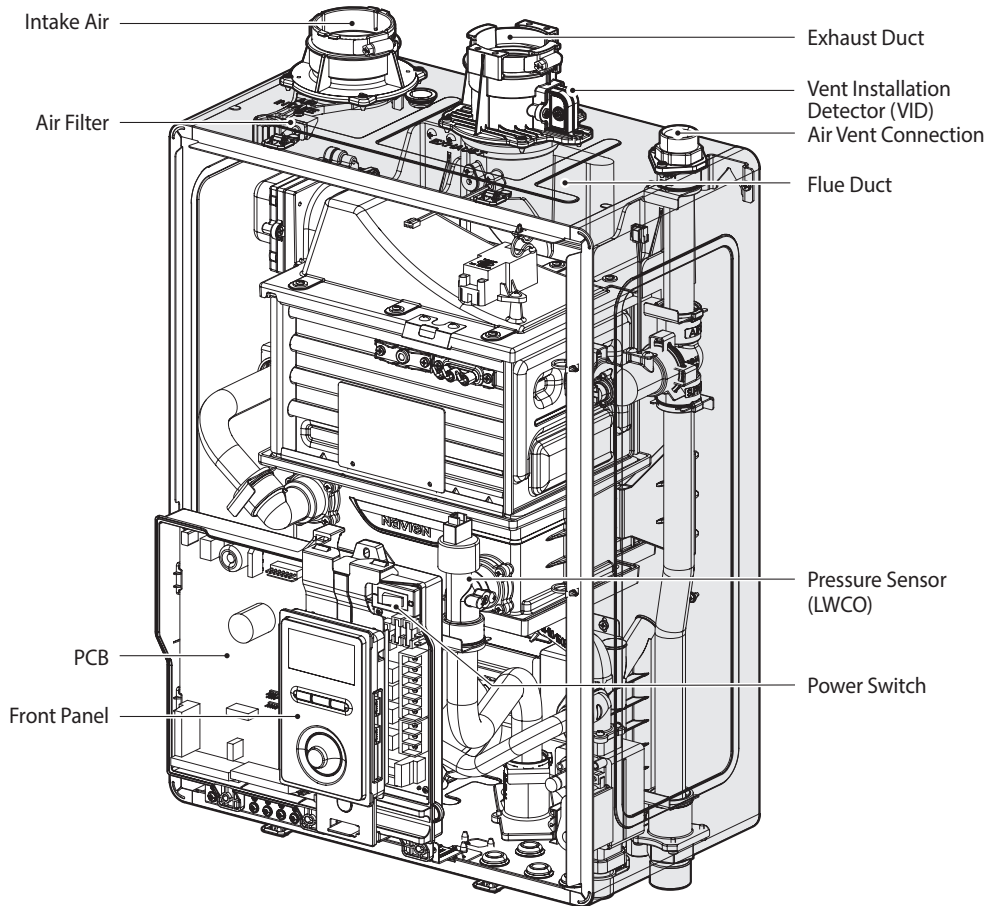

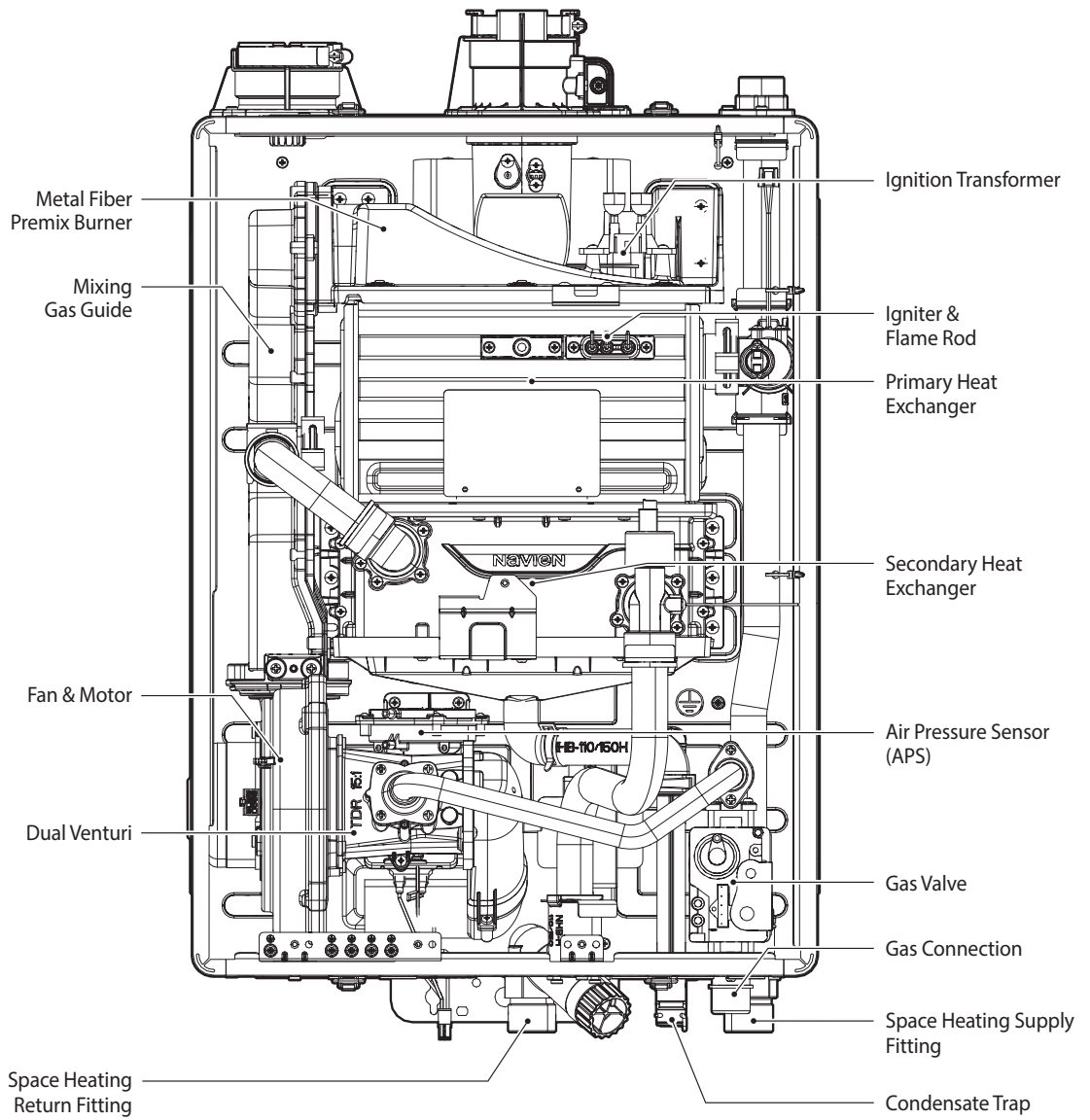

1.5 Dimensions

The following diagrams show the dimensions of the boiler and the table lists the supply connections.

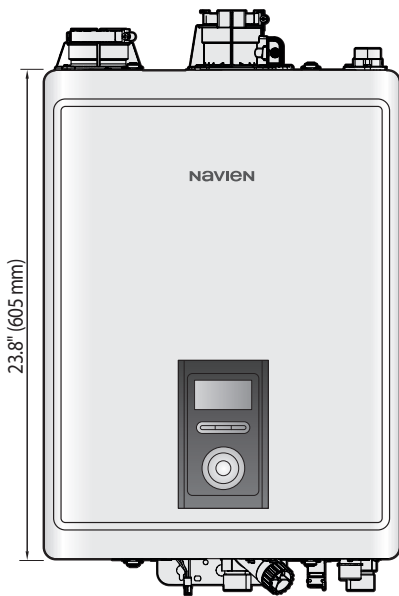

Supply Connections

	Description	Diameter
A	Air Intake	2 in
B	Exhaust Gas Vent	2 in
C	Air Vent Connection	¾ in
D	Rubber Grommet	1 in
E	Space Heating Return	1 in
F	Condensate Outlet	½ in
G	Gas Connection	¾ in
H	Space Heating Supply	1 in

Overhead View

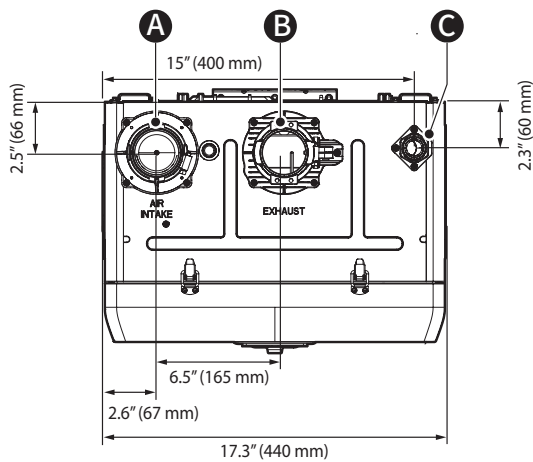

Supply Connections

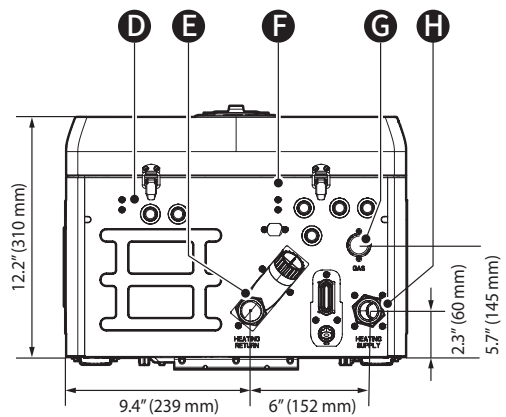

1.6 Rating Plate

The Navien NHB-H boilers come from the factory configured for use with Natural Gas (NG). **Before starting the installation**, check the rating plate located on the side of the boiler to ensure that the boiler matches the gas type, gas pressure, water pressure, and electrical supply available in the installation location. **If the boiler does not match each of these ratings, do not install the boiler.** If conversion to Propane Gas is required, the included gas conversion kit must be used. Refer to “12.1 Gas & High Altitude Conversion” on page 120 for details.

Note

The Propane Gas & High Altitude Conversion Kit is attached to the interior of the boiler cabinet. You will need to remove the front cover to access the Propane Gas & High Altitude Conversion Kit. If you need assistance, please call a licensed professional or Navien Technical Support at 1-800-519-8794.

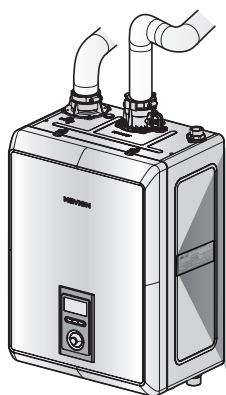

Rating Plate, *Plaque Signalétique

Direct Vent Boiler *Évacuation directe chaudière
Navien, Inc.

20 Goodyear, Irvine, CA 92618

Tel: 1-800-519-8794

FOR EITHER DIRECT VENT INSTALLATION OR FOR INSTALLATION USING INDOOR COMBUSTION AIR,
*POUR INSTALLATION AVEC ÉVACUATION DIRECTE OU AVEC AIR INTÉRIEUR COMBURANT

Model No., *Numéro de modèle
NHB-150H

Max./Min. Input Rating (Heating), *Entrée GPL max./min

150,000 Btuh / 10,000 Btuh

Category of boiler, *Catégorie de chaudière
Category IV

Max. Inlet Gas Pressure, *Pression max. de gaz d'entrée

Min. Inlet Gas Pressure, *Pression min. de gaz d'entrée

Manifold Pressure, *Pression d'admission

Electrical Rating, *Régime nominal électrique

Minimum relief valve capacity, *Capacité minimuma soupape.

Type of Gas, *Type de gaz
Natural Gas

Heating Capacity, *Capacité de chauffage

136,000 Btuh

Net AHRI Rating, *Régime de AHRI

118,000 Btuh

10.5 Inches W.C., *pouces W.C.

3.5 Inches W.C., *pouces W.C.

-0.40 Inches W.C., *pouces W.C.

AC *c.a. 120 Volts 60Hz Use less than 15 Amp, *Utilise moins de 15A

189 lbs/hr CSA/ANSI Z21.13:2022 - CSA 4.9:2022



Orifices necessary for Propane conversion are provided. *Les injecteurs nécessaires à la conversion au propane sont fournis.

Failure to use the correct gas can cause problems which can result in death, serious injury or property damage. *Le fait de ne pas utiliser le bon gaz peut causer des problèmes qui peuvent mener à la mort, causer des blessures graves ou endommager la propriété.

Consult your installation manual for more information. *Consultez votre manuel d'installation pour plus d'information.

This appliance is certified for use at altitudes up to 4,500 ft (1,370 m) in accordance to the latest CAN/CGA 2.17-High Altitude Installation procedures at normal manifold pressure. This appliance has also been tested up to 10,100 ft (3,078 m).

For installations at altitudes up to 10,100 ft (3,078 m), follow the directions provided in the High Altitude Installations sections of the Installation Manual. *Cet appareil est certifié pour une utilisation à des altitudes de 0 à 4 500 pieds (1 370 m) conformément aux toutes les procédures d'installation à haute altitude CAN/CGA 2.17 à une pression normale. Cet appareil a été testé jusqu'à 10 100 pieds (3 078 m). Pour les instructions d'installation à une altitude supérieure à 10 100 pieds (3 078 m), suivez les instructions fournies dans la section des installations à haute altitude du manuel d'installation.

This appliance must be installed in accordance with local codes or in the absence of local codes, the most recent edition of National Fuel Gas Code, ANSI Z223.1, in Canada use CAN/CGA B149.1 or 2 installation codes for Gas Burning Appliances.

*Cet appareil doit être installé conformément aux codes locaux, ou si l'il n'y a pas de codes locaux, la plus récente version du National Fuel Gas Code des E.-U., ANSI Z223.1, au Canada utilisez les codes d'installation CAN/CGA B149.1 ou 2 pour les appareils à gaz.

FOR YOUR SAFETY *POUR VOTRE SÉCURITÉ

Do not store or use gasoline or other flammable vapors and liquids in the vicinity of this or any other gas appliances. *Ne rangez pas et n'utilisez pas d'essence ou d'autres liquides ou vapeurs inflammables près de cet appareil ou de tout autre appareil électroménager.

⚠ WARNING

To prevent death, serious injury or property damage:

Before starting the installation, check the Rating Plate located on the side of the boiler to ensure that the boiler matches the gas type, gas pressure, water pressure, and electrical supply available in the installation location.

If the boiler does not match each of these ratings, do not install the boiler. Using a different gas type will result in abnormal combustion and malfunction of the boiler.

- ONLY a licensed professional should connect the gas supply.
- ALWAYS leak test the appliance and the gas connections before operating the appliance.
- This boiler cannot be converted from natural gas to propane without a Navien Propane Gas & High Altitude Conversion Kit. NEVER attempt a field conversion of this boiler without using the Navien Propane Gas & High Altitude Conversion Kit. Doing so will result in dangerous operating conditions and will void the warranty.

Navien Inc. is not liable for any property damage, personal injury or death resulting from improper conversions.

This appliance complies with the requirements of SCAQMD Rule 1146.2 for NOx emissions of 14 ng/J or 20 ppm at 3% O₂.

2. Installing the Boiler

2.1 Choosing an Installation Location

When choosing an installation location, you must ensure that the location provides adequate clearance for the boiler, adequate venting and drainage options, and sufficient access to gas, water, and electrical supplies. Carefully consider the following factors when choosing an installation location:

⚠ WARNING

- Do not install outdoors. Outdoor installation may result in property damage, severe personal injury, or death. Damage to the boiler resulting from installation outdoors is not covered by warranty.
- Do not install this boiler in a recreational vehicle, trailer, boat or other moving vehicles as it will result in a Carbon Monoxide Poisoning Hazard.

Note

- Installer must verify that at least one carbon monoxide detector is installed within the residential living space before placing the boiler into operation. Refer to the manufacturer's instructions and local codes as well as the Consumer Product Safety Commission (CPSC) and Environmental Protection Agency (EPA) recommendations for proper use of carbon monoxide alarms.
- If the boiler is installed in Massachusetts, refer to "Requirements for the State of Massachusetts" on page 139.

Compliance Requirements

- Local, state, provincial, and national codes, laws, regulations, and ordinances.
- National Fuel Gas Code, ANSI Z223.1-latest edition.
- Standard for Controls and Safety Devices for Automatically Fired Boilers, ANSI/ASME CSD-1, when required.
- National Electrical Code.
- For Canada only: B149.1 Installation Code, CSA C22.1 Canadian Electrical Code Part 1, CSA-B214-12 Installation code for hydronic heating systems, and any local codes.

Access to Utilities

- Water – the installation location should be near where the domestic water supply enters the building.
- Gas – the installation location should be near where the gas supply enters the building.
- Electricity – the installation location should be near where the electrical supply enters the building.

Humidity and Contact with Water

When installing the boiler, avoid places with excessive humidity. The boiler has electric gas ignition components. Moisture can get inside the boiler and damage the ignition system. The boiler must be installed in a way to ensure that the gas ignition system components are protected from water (dripping, spraying, rain, etc.) during operation and service.

Adequate Drainage

The boiler produces a significant amount of condensate during operation. The boiler should be located near a suitable drain and where damage from a possible leak will be minimal. Installing the boiler in a location without a drain will void the warranty and Navien will not be responsible for water damages that occur as a result. For more information about condensate drainage, refer to "3.2 Connecting the Condensate Drain" on page 23.

The boiler must be located in an area where leakage of the unit or connections will not result in damage to the area adjacent to the appliance or to lower floors of the structure. When such locations cannot be found, installation of an adequately drained drain pan under the boiler is highly recommended. When installing the drain pan, ensure that the installation does not restrict combustion air flow.

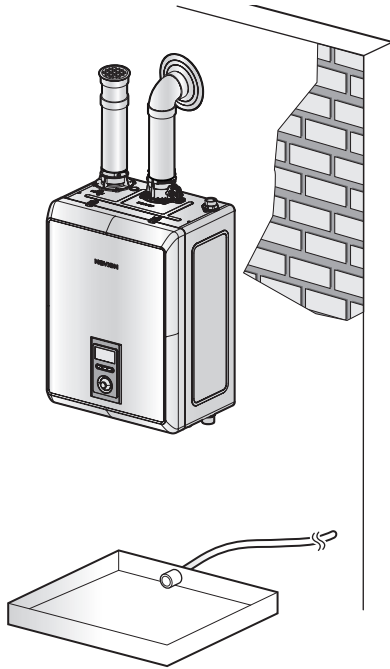

Adequate Venting and Ventilation

Select a location that requires minimal venting. Consider venting restrictions caused by windows, doors, air intakes, gas meters, foliage, and other buildings. For more information about venting, refer to “5. Venting for Combustion Air” on page 52.

To ensure adequate venting and ventilation, follow these guidelines:

- Maintain proper clearances from any openings in the building.
- Ensure that the vent termination is at least 12 in (300 mm) above ground, 12 in (300 mm) above the highest anticipated snow level, or as required by local codes, whichever is greater.
- Do not enclose the vent termination.
- Install the exhaust vent in an area that is free from any obstructions, where the exhaust will not accumulate.
- Avoid Installations of the boiler where moisture from the exhaust may discolor or damage walls.
- Do not install the boiler in bathrooms, bedrooms, or any other occupied rooms that are normally kept closed or not adequately ventilated.

Adequate Installation Clearances

NOTICE

Do not install the boiler on carpeting.

Install the boiler in an area that allows for service and maintenance access to utility connections, piping, filters, and traps. Based on the installation location, ensure that the following clearances are maintained:

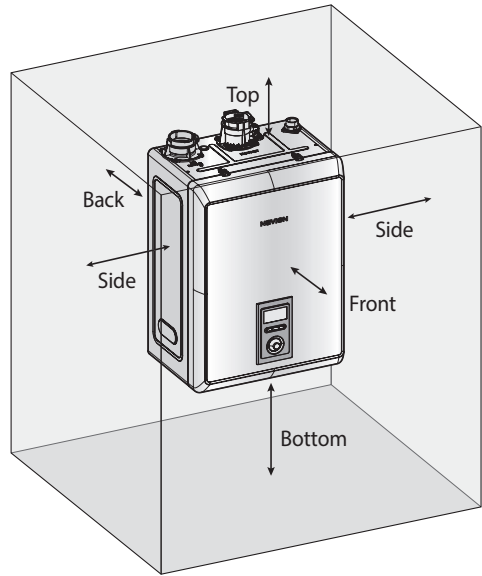

Clearance from:	Indoor Installation
Top	9 in (229 mm) minimum
Back	0.5 in (13 mm) minimum
Front	4 in (100 mm) minimum
Sides	3 in (76 mm) minimum
Bottom	12 in (300 mm) minimum

CAUTION

It is necessary to leave clearance for service access.

Clean, Debris and Chemical-free

Combustion Air

- Do not install the boiler in areas where dust and debris may accumulate or where hair sprays, spray detergents, chlorine, or similar chemicals are used.
- Do not install the boiler in areas where gasoline or other flammables are used or stored.
- Ensure that combustible materials are stored away from the boiler and that hanging laundry or similar items do not obstruct access to the boiler or its venting.

Operating Temperature

The ambient temperature at the installation location must be above 32°F (0°C) and below 120°F (49°C).

High Elevation Installations

This unit may be installed at elevations up to 10,100 ft (3,078 m) for use with natural gas and propane. Refer to “6. Setting the DIP Switches” on page 67 for the appropriate altitude setting.

WARNING

- ALWAYS read and follow the Natural Gas High Altitude Conversion Guide when installing the gas orifice included with the kit in order to prevent death, serious injury or property damage.
- The front cover will need to be removed from the boiler to access the High Altitude Conversion Kit.
- Do NOT install this boiler at elevations above 10,100 ft (3,078 m).

2.2 Mounting the Boiler to the Wall

Navien NHB-H boilers come with an upper mounting bracket that is pre-drilled at 16 in (400 mm) on center for easy installation on standard wall studs. If the strength of the wall is insufficient or if the framing is non-standard or uneven, reinforce the area before installing the boiler. Avoid installation on common walls as the unit will make some operational noises while it is running.

To mount the boiler to the wall:

1. Affix the bracket securely to the wall and ensure that it is level and that it can support the weight of the boiler.
2. Align the grooves on the back of the boiler with the tongues on the mounting bracket and hang the boiler on the bracket.

When mounted with the mounting bracket, the boiler will have a $\frac{5}{8}$ in (16 mm) clearance from the back of the wall.

3. Install two set screws through the bracket at the bottom of the boiler to secure the boiler on the wall.

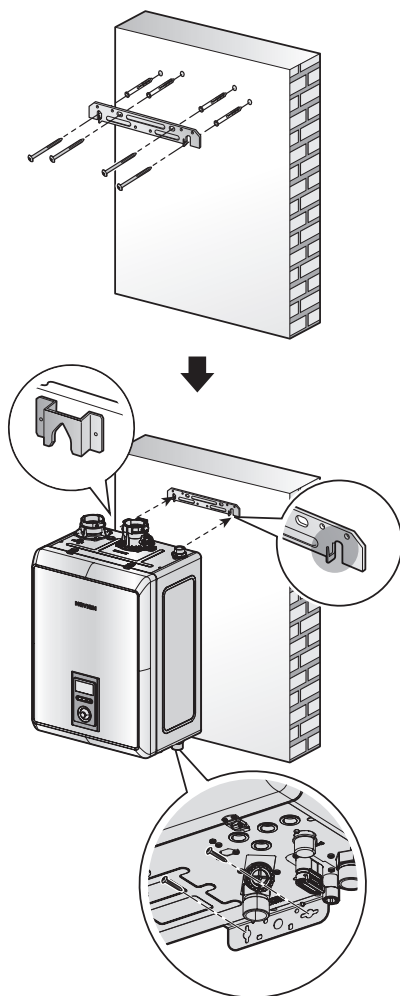

! WARNING

- **The boiler is heavy.** Always lift the unit with assistance. Be careful not to drop the boiler while lifting or handling it to avoid bodily injury or damage to the unit.
- Install the boiler in the upright, vertical position. Installation in any other orientation will result in improper boiler operation and property damage, and could result in serious personal injury or death.

NOTICE

- Ensure that the structure of the installation location is sturdy enough to support the full weight of the installed boiler, including the water contained in the heat exchanger and related piping.
- The wall must be vertical, and it must be capable of carrying the weight of the boiler.
- Do not mount the boiler to drywall that has not been reinforced.
- **Do not** rest the boiler on the bottom end after removing it from the shipping carton. Doing so may result in excessive pressure on protruding pipes and resulting in product damage. If you must put the boiler down, lay it on its back or put it inside the protective shipping base.

3. Installing the System Piping

Prior to connecting piping to the boiler, flush the entire system to ensure it is free of sediment, flux, solder, scale, debris or other impurities that may be harmful to the system and boiler. During the assembly of the heating system, it is important to keep the inside of the piping free of any debris including construction dust, copper burr, sand and dirt.

For retrofits, all system piping including radiators, must be cleaned of all build-up including sludge and scale. All systems, old and new, must be cleaned to remove flux, grease and carbon residue. Navien recommends cleaning the boiler system with cleaning products specially formulated for boiler systems. For retrofit applications with heavy limescale and sludge deposits, a heavier duty cleaner may be required. For information on performing the cleaning, follow the instructions included with the boiler system cleaner products.

NOTICE

- Failure to rid the heating system of the contaminants listed above will void your warranty and may result in premature heat exchanger failure and property damage.
- To avoid damaging the connectors on the boiler, use two wrenches when tightening piping to the boiler. Use one wrench to prevent the connector at the boiler from turning, and use the other wrench to tighten the connection. Damaged connectors may result in system leaks.
- Properly support the piping with hangers. Do not allow the piping to be supported by the boiler or its accessories.

3.1 Installing a Space Heating System

The primary and secondary heat exchangers of the Navien NHB-H boilers are designed to attain the highest level of heat transfer in a compact design. To accomplish this, the heating water flows through a series of tubes (secondary heat exchanger) and finned tubes (primary heat exchanger), designed to maximize the heat transfer area. To maintain the efficient and reliable operation of the heat exchangers, and to avoid heat exchanger failure, it is critical to ensure the rules and guidelines in this section are followed.

⚠ WARNING

Failure to follow the instructions provided in this section will void the warranty and may result in property damage, fire, serious injury or death.

3.1.1 Guidelines for a Space Heating Installation

Read and follow the guidelines listed below to ensure safe and proper installation of a boiler heating system.

Freeze Protection for a Space Heating System

- Freeze protection products may be used for the space heating system. Freeze protection for new or existing systems requires specially formulated glycol, which contains inhibitors to prevent the glycol from attacking the metallic system components.
- Before using freeze protection products, ensure that system fluid contains proper glycol concentration and the inhibitor level is appropriate. Navien recommends against exceeding a 35% concentration of glycol.
- When using the freeze protection products, the system must be tested at least once a year, and as recommended by the manufacturer of the glycol solution.
- When using the freeze protection products, allowance should be made for expansion of the glycol solution.
- Freeze damage is not covered by the warranty.
- The use of glycol results in a greater head loss due to its higher viscosity compared to water.

NOTICE

For systems requiring freeze protection, use only inhibited propylene glycol, specially formulated for hydronic heating systems; use of other types of antifreeze may be harmful to the system and will void the warranty.

System Pressure

- The Navien NHB-H boiler is intended solely for use in pressurized closed loop heating systems operating with 12-30 psi water pressure at the boiler outlet. To obtain the minimum system design pressure, follow the piping diagrams illustrated in this section.
- The Navien NHB-H boiler's space heating system is not approved for operation in an "open system", thus it cannot be used for direct potable water heating or to process heating of any kind.

Oxygen Elimination

This boiler may only be installed in a pressurized closed-loop heating system, free of air (oxygen) and other impurities. All of the air should be removed from the system during commissioning via strategically placed and adequately sized air removal appliances, located throughout the heating system.

Note See the examples of system application at the end of this section detailing the installation location of the air removal device, in case an additional air removal device is required for a specific application.

NOTICE

- Immediately repair any leaks in the system piping to avoid adding make-up water. Make-up water adds oxygen and minerals to the system that may lead to heat exchanger failure.
- Do not solder piping directly onto the water connections, as the heat may cause damage to internal components. Use threaded water connections only.
- Failure to follow these instructions may result in poor performance, unnecessary wear of system components and premature failure.

3.1.2 Essential Elements in a Space Heating System

Air Vent

The Navien NHB-H boiler comes with an air vent and an adapter bushing that must be connected to the air vent connection. The vent efficiently removes the air from the boiler. The following figure illustrates an example of a typical air vent installation.

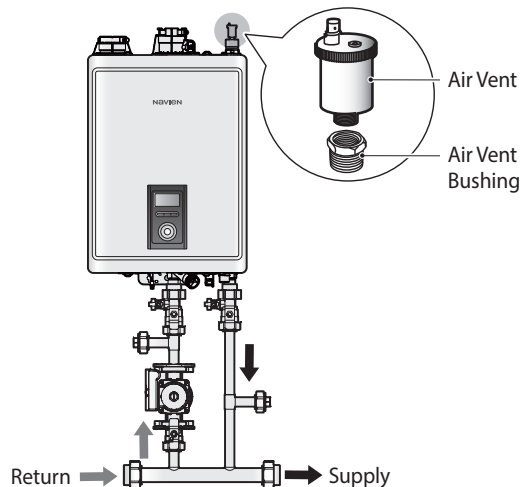

Also, an external LWCO and a pressure relief valve can be installed at the air vent connection. Refer to "Low Water Cut Off (LWCO) Device" on page 17 and "Pressure Relief Valve" on page 18.

Note Before installing the vent line and any vent fittings, you must be familiar with the LWCO and pressure relief valve installation guidelines.

Low Water Cut Off (LWCO) Device

Internal LWCO

The Navien NHB-H boiler is equipped with a factory-installed, pressure-sensing type low water cutoff (LWCO) device. The minimum operation pressure for this device is 6 psi by default.

Note When the built-in water pressure sensor detects insufficient water level in the boiler, error code E302 is displayed on the front panel requiring a manual boiler reset.

Refer to local codes to determine if a LWCO device is required for your system and ensure that the built-in device meets the requirements.

External LWCO

If local codes require a separate LWCO device, install one separately. Combining the LWCO with the air vent simplifies the installation. The following illustration shows an example of a separately installed external LWCO.

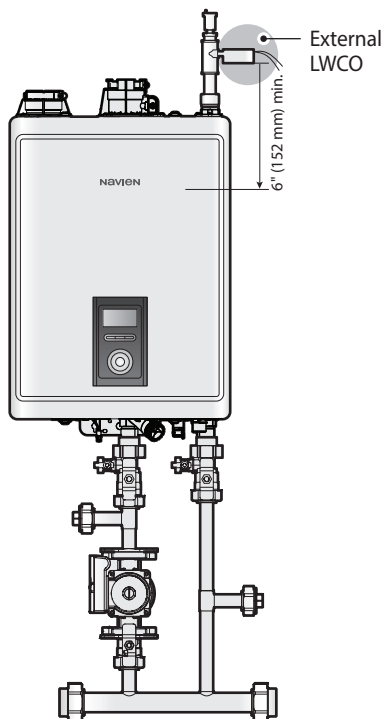

The external LWCO must be installed at least 6 in (152 mm) above the top of the heat exchanger. Refer to “3.6.2 Wiring Diagram - External LWCO” on page 34 for typical wiring connections of the LWCO to the boiler PCB.

⚠ WARNING

Electric Shock Hazard

ALWAYS check that the power to the boiler is turned off before making the boiler may fail and result in serious injury, or death if power is supplied during wire connection. Product failures caused by incorrect installation are not covered by warranty.

Backflow Preventer

Install a backflow preventer valve in the make-up water supply to the unit as required by local codes.

Expansion Tank

An expansion tank must be installed in the space heating piping to prevent excessive pressure from building in the system. See the examples of system application at the end of this section for the installation location. Refer to the expansion tank manufacturer’s instructions for additional details.

Follow the guidelines below when installing an expansion tank.

- Connect an air separator to the expansion tank only if the air separator is located on the suction side of the system pump.
- Install the make-up water connection at the same location as the expansion tank’s connection to the system.
- When replacing an expansion tank, consult the expansion tank manufacturer’s literature for proper sizing.
- For diaphragm expansion tanks, always install an automatic air vent on the top side of the air separator to remove residual air from the system.

Isolation Valves and Unions

- Full port ball valves are required for the boiler system. Failure to use full port ball valves could result in a restricted flow rate through the boiler.
- Check valves are recommended for installation. Failure to install check valves could result in a reverse flow condition during pump(s) off cycle.
- Unions are recommended for unit serviceability.

Pressure Relief Valve

To complete the space heating system installation, you must install a $\frac{3}{4}$ in, 30 psi (max.) pressure relief valve on the space heating hot water outlet. An ASME approved HV pressure relief valve for space heating system is supplied with the boiler.

⚠ WARNING

- Installing the pressure relief valve improperly may result in property damage, personal injury, or death. Follow all instructions and guidelines when installing the pressure relief valve. The valve should be installed only by a licensed professional.
- The pressure relief valve must be installed at the boiler outlet and in the vertical position, as shown in this section, with the drain pipe outlet exiting the side of the pressure relief valve horizontally and elbowing down.
- Install the pressure relief valve as close to the boiler as possible. No other valve should be installed between the pressure relief valve and boiler.

When installing the pressure relief valve, follow these guidelines:

- Ensure that the valve's discharge capacity is equal to or greater than the maximum pressure rating of the boiler's space heating system.
- Ensure that the maximum BTU/H rating on the pressure relief valve is equal to or greater than the maximum input BTU/H rating of the boiler.
- Direct the discharge piping of the pressure relief valve so that hot water does not splash on the operator or equipment.
- Attach the discharge line to the pressure relief valve and install the end of the line within 6-12 in (150-300 mm) above the floor.
- Ensure that the discharge line provides complete and unobstructed drainage. Do not install a reducing coupling or other restrictions on the discharge line.

If the relief valve discharges periodically, this may be caused by thermal expansion when the expansion tank is full or undersized. Do not plug the relief valve.

Refer to the following illustration for a pressure relief valve installation in the space heating system. A Watts M330-M1 pressure relief valve ($\frac{3}{4}$ in, HV, Max 30 psi) is provided with the boiler.

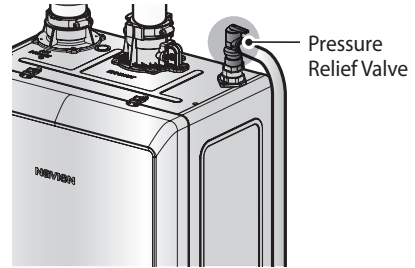

⚠ WARNING

- To prevent scalding, burns and water damage, always route the discharge line to a safe location.
- To prevent serious injury or death, the pressure relief valve should be checked at least once every three years by manually operating the relief valve.
- Before manually operating the valve, check the discharge line and discharge location to ensure you or others will not come in contact with hot water. Hot water can cause burns and may result in serious injury or property damage.

Note

All field supplied pressure relief valves must be ASME certified.

3.1.3 Space Heating System Piping

When connecting the space heating system, follow these guidelines:

- Carefully tighten all connections to avoid damage to fittings.
- After installing the boiler, check the space heating system's operation and inspect for leaks.

The optional Navien manifold system enables easy separation of the boiler (primary loop) from the system (secondary loop(s)). Refer to the illustration below for an example of the piping connections for a Navien manifold system (primary zone).

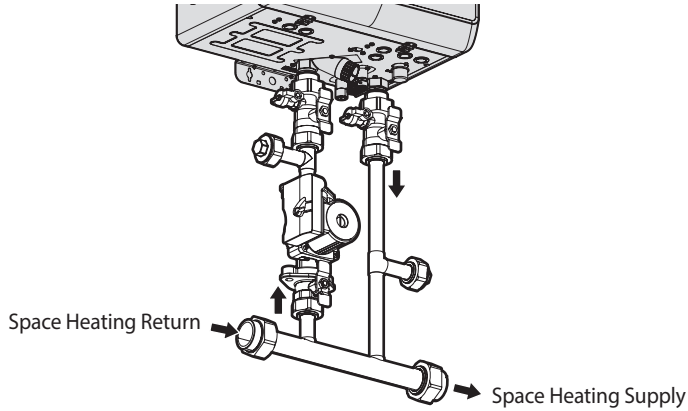

The following tables list the specifications for the available pumps and Navien's manifold system. If you are not using one of the pumps listed below, you must use a circulator with check valve installed at pump outlet or a pump with an integral check valve.

Model Number

Item	NHB-055H	NHB-080H	NHB-110H	NHB-150H
Manifold System	GXXX002396			

Pump Specifications

Manufacturer	NHB-055/080/110H	NHB-150H
Grundfos	UPS 15-58	UPS 26-99
Armstrong	Astro 230CI	Astro 280CI
Taco	0015-MSF3-IFC	0013-MSF2-IFC
Wilco	Star S 21F	TOP-S 1.25x25
Bell & Gossett	NRF-25	NRF-36

Note

If you are not using one of the pumps listed in the above tables, use a pump with an integral check valve or install a check valve at the pump outlet. Refer to the performance curve on page 21 to select a pump that suits your application. The boiler can supply up to a maximum of 2.5 A current at the boiler pump connection terminal.

Pressure Loss Data Curve

NHB-055/080H

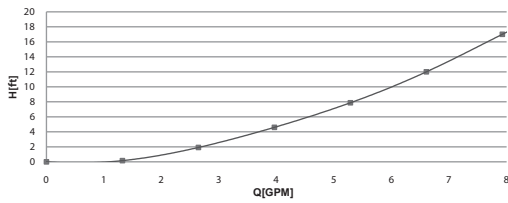

NHB-110H

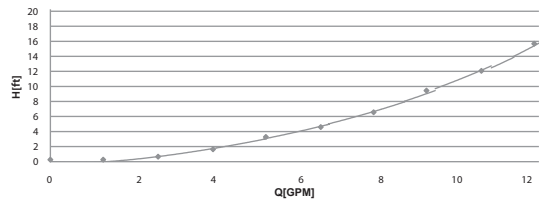

NHB-150H

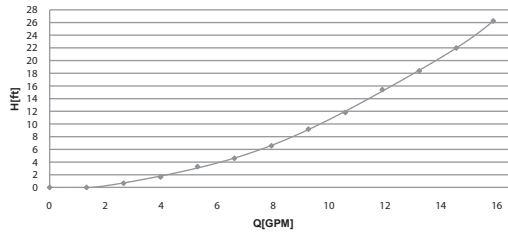

Temperature Rise Conditions

Model	20°F ΔT @ 100% Water		25°F ΔT @ 100% Water		35°F ΔT @ 100% Water	
	Flow Rate (GPM)	Head (Ft)	Flow Rate (GPM)	Head (Ft)	Flow Rate (GPM)	Head (Ft)
NHB-055H	5	7.2	4	4.7	2.9	2.6
NHB-080H	7.3	14.8	5.8	9.5	4.2	5.2
NHB-110H	10	10.9	8	7.0	5.7	3.5
NHB-150H	13.5	19.8	10.8	12.7	7.7	6.4

Pump Sizing for Use with Glycol

The use of glycol results in a greater head loss due to its higher viscosity compared to water. Heat transfer is also reduced as the glycol concentration increases. The corrected flow rate and head loss values below must be used when sizing the boiler pump in order to maintain similar performance as using 100% water for the heating system. Refer to the chart below.

Model	20°F ΔT @ 30% Glycol		25°F ΔT @ 30% Glycol		35°F ΔT @ 30% Glycol	
	Flow Rate (GPM)	Head (Ft)	Flow Rate (GPM)	Head (Ft)	Flow Rate (GPM)	Head (Ft)
NHB-055H	5.4	10.0	4.3	6.5	3.1	3.5
NHB-080H	7.8	20.2	6.3	13.4	4.5	7.0
NHB-110H	10.8	15.2	8.6	9.6	6.1	4.8
NHB-150H	14.5	27.4	11.6	17.5	8.3	9.0

Note Do not exceed a maximum concentration of 35% glycol.

Minimum Flow Rates through the Boiler for Use with Glycol

Model	Minimum Flow (GPM)
	For use With 30% Glycol
NHB-055H	2.3
NHB-080H	3.4
NHB-110H	4.6
NHB-150H	6.2

Note If the flow rate is below the required value for the specific boiler model as shown on the chart, it may result in noise and/or potential damage to the boiler.

3.2 Connecting the Condensate Drain

The Navien NHB-H boiler creates condensation when it operates. This condensation has an acidic pH of 3-5. Follow all local codes and regulations when disposing of condensate from the boiler. We recommend draining the condensate into a suitable external drain. However, other suitable waste drain locations may be used according to the local codes.

⚠ WARNING

- Fill the condensate trap with water after installing the condensate drain pipe.
- Do not cap or plug the integrated condensate line. If prevented from draining, condensate can damage the boiler.
- The condensate line must have a negative slope to drain properly.
- NEVER drink or allow animals to drink condensate. The pH of the condensate could cause serious injury.

Before connecting the condensate drain, choose one of the following disposal options:

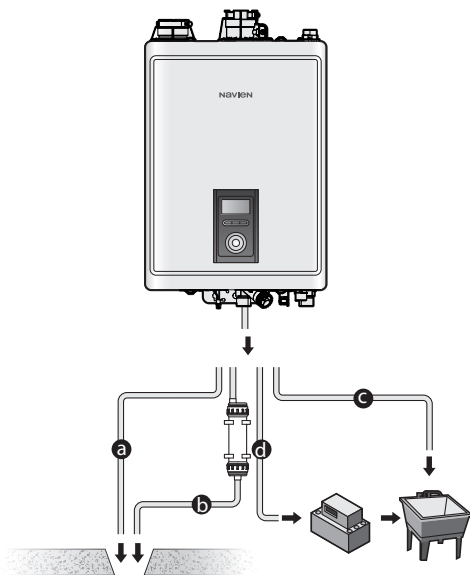

- a. From the boiler directly into an external drain.

Note Do not install a fixed connection for the drain.

- b. From the boiler, through a neutralizing agent, and then into an external drain (refer to “3.2.1 Condensate Neutralizer Kit” on page 24).

Note If you choose this option, the neutralizing agent must be replaced periodically. Depletion of the neutralizing agent will vary, based on the usage rate of the boiler. During the first year of operation, the neutralizer should be checked every few months for depletion and replaced as needed.

- c. From the boiler into a laundry tub.

Note The bottom of the boiler must be higher than the top of the laundry tub to use this option. The condensate line must have a negative slope to drain properly.

- d. From the boiler into a condensate pump, and then into a laundry tub.

Note A pump can be used when there is a long distance between the boiler and the laundry tub or when the bottom of the boiler is lower than the top of the laundry tub.

To connect the condensate drain:

1. Connect a drain line to the ½ in fitting at the bottom of the boiler.

Use only corrosion-resistant material for the drain line, such as PVC or CPVC. Do not reduce the size of this fitting or the drain line to less than ½ in.

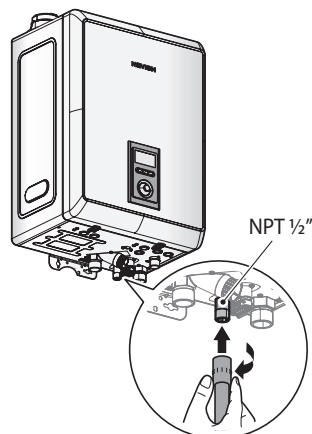

2. Place the free end of the drain line into an appropriate drain.
3. If you are using a condensate pump, ensure that the pump allows for up to 3 GPH of drainage for each boiler in the system.
4. If you are not using a condensate pump, ensure that the drain line is pitched downward at a minimum slope of ¼ in per foot.

NOTICE

To prevent property damage, do not allow condensate line to freeze or become obstructed or condensate can flow from the drain.

5. Fill the condensate trap by pouring water into the boiler's exhaust vent until water flows through the condensate drain.

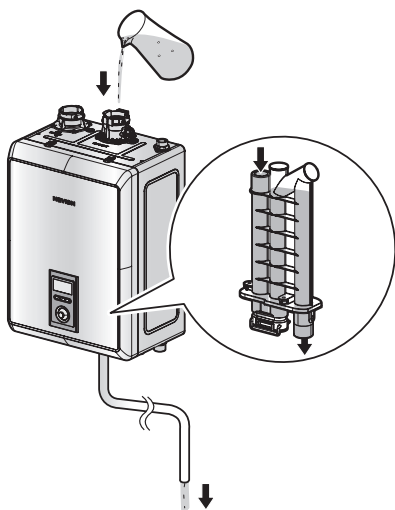

NOTICE

To prevent property damage, do not allow condensate line to freeze or become obstructed or condensate can flow from the drain.

3.2.1 Condensate Neutralizer Kit

WARNING

To prevent serious injury or death:

- DO NOT allow exhaust flue gases to vent through the neutralizer. Inhalation of flue gases can result in carbon monoxide poisoning.
- ALWAYS install the neutralizer so its inlet and discharge are closer to the floor than the condensate drain.
- ALWAYS install an overflow bypass connection between the appliance and the neutralizer to prevent the backflow of condensate into the appliance.
- DO NOT connect more than one appliance to the neutralizer.

If option 'b' (p. 23) is selected as the disposal option, the Navien condensate neutralizer kit is recommended. The condensate from the appliance flows through the neutralizing media and increases the pH of the condensate. An increased pH prevents corrosion of the installation's drainage system and the public sewer system.

Installation

- The inlet has a center connection port and the outlet has an offset connection.
- Install the neutralizer on the wall or the floor and secure it using the brackets supplied with the kit.
- If the neutralizer is installed horizontally, rotate the neutralizer to position the outlet at the highest point (Figure 1).
- If the neutralizer is mounted vertically, ensure that the outlet is higher than the inlet (Figure 2).
- Ensure that the condensate runs freely to the drain.
- Ensure all connections are made to prevent the backflow of condensate. Use corrosion resistant piping and secure all piping to prevent movement.

Note

Do not install condensate piping in areas where the temperature drops below freezing point. Protect piping in high pedestrian areas from damage and vibration.

- If local codes permit, install a Y-fitting as a bypass drain for increased safety when the condensate drain is blocked. Connect the Y-fitting as shown in the installation diagram and ensure that the condensate runs freely to the drain.
- Ensure that the discharge connection is accessible. Access to the discharge connection is required for maintenance and pH testing.
- If there is insufficient gradient for drainage, install a drainage pump designed for boiler and water heater condensate removal.

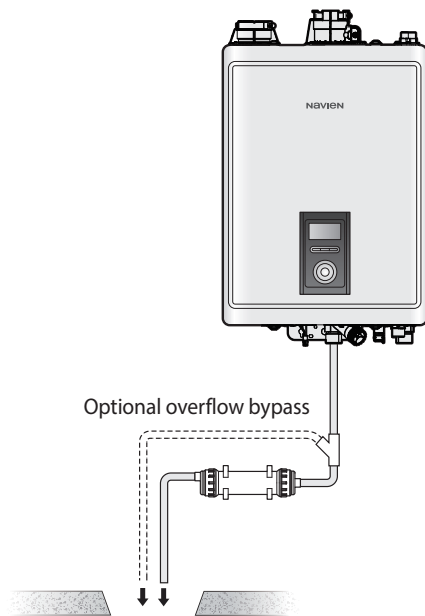

Figure 1. Horizontal installation

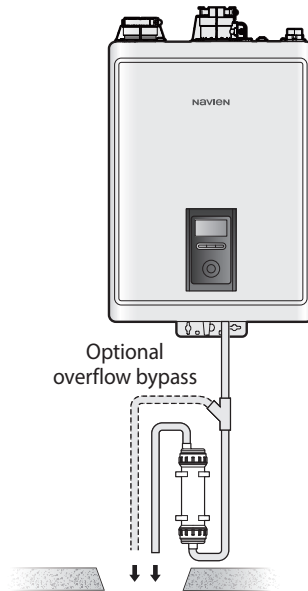

Figure 2. Vertical installation

Maintenance

Periodically monitor the level of media in the neutralizer and test the pH level at the outlet. We recommend an annual pH test using recognized test strips or an electronic pH meter to obtain precise measurements. Replace the neutralizing media when the pH drops below the minimum level required by the local water authority. If the pH level is not specified, replace the neutralizing media when the pH is below 6.0. For replacement media, contact your local Navien distributor.

3.3 Filling the System

Before filling the boiler, completely unscrew and remove the air vent cap to enable the system to fill properly. Also, loosen the vent screws on the system and boiler pumps to prevent the air from being trapped inside the pumps.

Note If the air vent cap is only partially loosened, the air vent may not allow for the boiler to fully purge. The cap must be completely unscrewed and removed to complete the procedure.

Replace the air vent cap and tighten the vent screws on the pumps when the system is full.

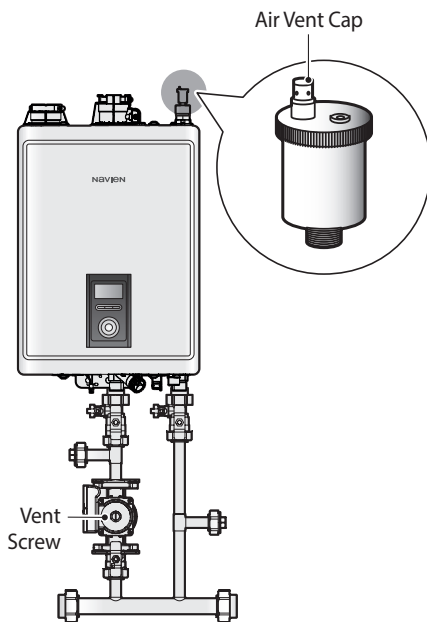

NOTICE

- Ensure that the vent cap is re-installed and the vent screws on the system and boiler pumps are properly tightened before testing or operating the system.
- Ensure that the pressure relief valve is closed before testing or operating the system.

3.3.1 Make-up Water Connection

An external make-up water connection is required. The illustration below shows an example of an external water supply connected to the system piping.

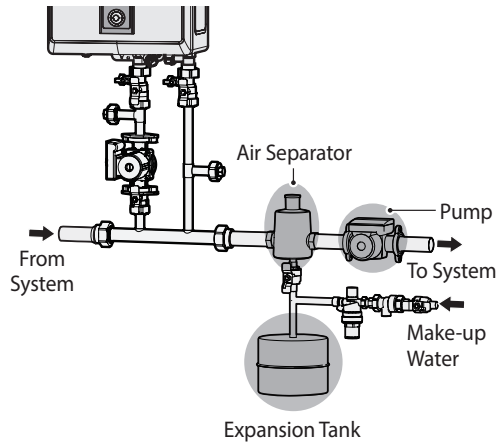

3.4 Testing the Water System

WARNING

To prevent death, serious injury or property damage:

Ensure that the boiler is full of water before firing the burner. Operating the unit without completely filling it could cause abnormal operation of the boiler and potential product damage. Such damage is not covered by the warranty.

Perform a leak test after installing the boiler's water system to make sure that the system has been installed properly. Follow the instructions below to perform a fill test on the water system.

1. Fill the system only after ensuring that the water chemistry meets the requirements.

Contaminant	Maximum Allowable Level
Total Hardness	Up to 200 mg/l (12 grains/gallon)
Aluminum	0.05 to 0.2 mg/l
Chloride	Up to 250 mg/l
Copper	Up to 1.0 mg/l
Iron	Up to 0.3 mg/l
Manganese	Up to 0.05 mg/l
pH	6.5 to 8.5
Sulfate	Up to 205 mg/l
Total Dissolved Solids (TDS)	Up to 500 mg/l
Zinc	Up to 5 mg/l
Chlorine	Up to 4 mg/l

Note Proper maintenance of the boiler is required when water quality does not meet standards. Damage caused by poor water quality is not covered under warranty. The table above shows the maximum contaminant levels allowed. If you suspect that your water is contaminated in any way, discontinue the use of the boiler and contact an authorized technician or licensed professional.

2. Close the manual and automatic air vents and the boiler drain valve.
3. Fill the boiler to the correct system pressure. The correct pressure will vary with each application. The typical cold water fill pressure for a residential system is 12 psi. The pressure will rise when the boiler is turned on and the system water temperature increases. The operating pressure must never exceed the relief valve pressure setting.
4. At initial fill and during boiler start-up and testing, check the system thoroughly for leaks. Repair any leaks before proceeding further.

NOTICE

Eliminate all system leaks. The continual introduction of fresh makeup water will reduce boiler life. Minerals can build up in the heat exchanger, reducing heat transfer, overheating the heat exchanger and causing heat exchanger failure.

The system may have residual substances that could affect water chemistry. After the system has been filled and leak tested, verify that water pH and chlorine concentrations are within the acceptable range by performing sample testing.

WARNING

Before operating the boiler for the first time, ensure that the boiler system is filled with water. Purge the air inside the system to avoid damage to the boiler.

3.5 Considerations for System Applications

Read and follow the guidelines listed below when installing system piping for the Navien NHB-H boiler:

- System application drawings are intended to explain the system piping concept only.
- For the upstream side of all pumps, use straight pipes with a minimum inside diameter of ½ in (12 mm).
- Provide a system expansion tank following the guidelines on page 18.
- System installations must comply with all local codes.

Air Removal

The boiler and system piping layout must be configured to promote the removal of air from the water. Air vents and bleeders must be strategically placed throughout the system to aid in purging the air from the system during commissioning of the boiler. The system must also employ the use of a strategically located air removal device, such as an air eliminator designed to remove the air from the water as it flows through the system.

Follow the installation instructions included with the air removal device when placing it in the system; air removal devices generally work better when placed higher in the system. Always locate air removal devices in areas of the system that have a guaranteed positive pressure, e.g., in close proximity to the water fill and expansion tank.

Note Connecting an air vent on top of the boiler is recommended.

Expansion Tank

The expansion tank must be sized in accordance with the water volume of the system as well as the firing rate of the appliance. It is important to locate the expansion tank, and make-up water connection, on the inlet side of any pump in the system, as doing so will guarantee the lowest pressure in the system will be at least equal to the tank and make-up water pressure.

Ensure the expansion tank cannot become isolated from the boiler anytime the system is operating. Failure to follow these instructions may lead to discharge from the pressure relief valve, which may result in property damage or injury.

Note The installation of flow checks, motorized valves or other shutoff devices (other than for the purpose of servicing) are not permitted between the location of the “Closely Spaced Tees” and the expansion tank.

Air Handler Interface

The Navien NHB-H boiler can control the operation of an air handler when a thermostat is used in combination with the air handling unit. The Air Handler Interface is designed to stop air handler operation when the boiler’s space heating function is not operating due to DHW supply demands, boiler errors, or low water conditions.

The air handler contacts (A/H) turn off when the following conditions arise:

- The PCB DIP SW2 (Set of 8 Switches) #7 is set to ON.
- Thermostat is turned off.
- The boiler is supplying DHW, or it is in stand-by mode for DHW demand.
- Level 2 or higher errors occur.
- The boiler is turned off.

⚠ CAUTION

- **Do not remove the front cover unless the power to the boiler is turned off or disconnected.** Failure to do so may result in electric shock.
- Configure only the DIP switches that require adjustment according to the instructions in this manual. Do not adjust any other DIP switches.

Thermostat Configuration for the Air Handler Interface

Set the PCB DIP SW2 (Set of 8 Switches) #7 to down position (OFF) to use a thermostat with the Air Handler.

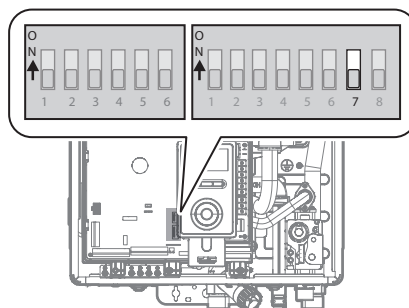

Refer to the “3.6.9 Wiring Diagram - Air Handler” on page 43 for wiring connections.

WARNING

- Do not turn the power on until electrical wiring is finished. Disconnect power before servicing. Death or serious injury from electrical shock may result if power is supplied to the boiler during electrical wiring or servicing.
- The boiler, when used in conjunction with an air conditioning system, must be installed so that the chilled medium is piped in parallel with the heating boiler. Appropriate valves must be used to prevent the chilled medium from entering the boiler.
- If the boiler is connected to heating coils located in air handling units where they can be exposed to refrigerated air, use flow control valves or other automatic means to prevent gravity circulation of the boiler water during the cooling cycle.

Configuring a Zone System

The NHB-H boiler can control up to 3 zones utilizing zone valves or zone pumps. After installing the system, the boiler operation must be configured accordingly using the front panel.

To configure a zone system:

On the front panel, press the Menu button (**M**) to enter the setting menu, and then select **2. Space Htg Operation > 2.Zone Settings**.

3.5.1 Examples of System Applications

Refer to the following examples to properly implement a system for space heating, DHW supply, or both. These examples are provided to suggest basic guidelines when you install the boiler system. However, the actual installation may vary depending on the circumstances, local building codes, or state regulations. Check the local building codes and state regulations thoroughly before installation, and comply with them fully.

WARNING

Ensure the power is turned off while making wiring connections. Boiler components or the boiler may fail and result in serious injury or death if power is supplied during wire connection. Product failures caused by incorrect installation are not covered by warranty.

3.5.2 System Application - Zone System with Zone Valves (Primary/Secondary Piping)

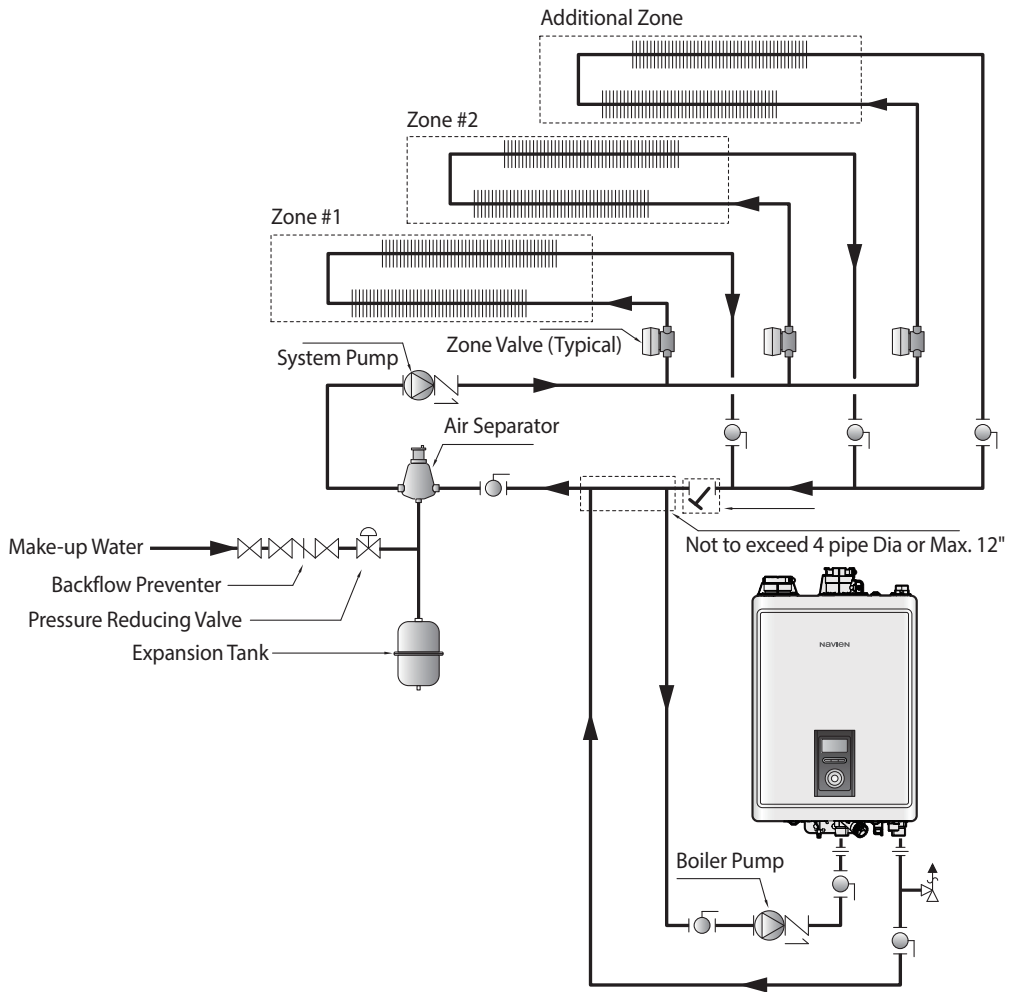

Note

- System application drawings are intended to explain the system piping concept only.
- Install a filter in the system return to remove foreign objects from the system. Foreign objects inside the system may result in abnormal system operation.
- Refer to “3.3 Filling the System” on page 26 for make-up water connections and refer to the requirements of your local codes to ensure compliance.
- Use a pump with an integral check valve or install a check valve at the pump outlet.
- Refer to “3.6.5 Wiring Diagram - Zone Valve System” on page 39 for wiring connections.

3.5.3 System Application - Zone System with Pumps (Primary/Secondary Piping)

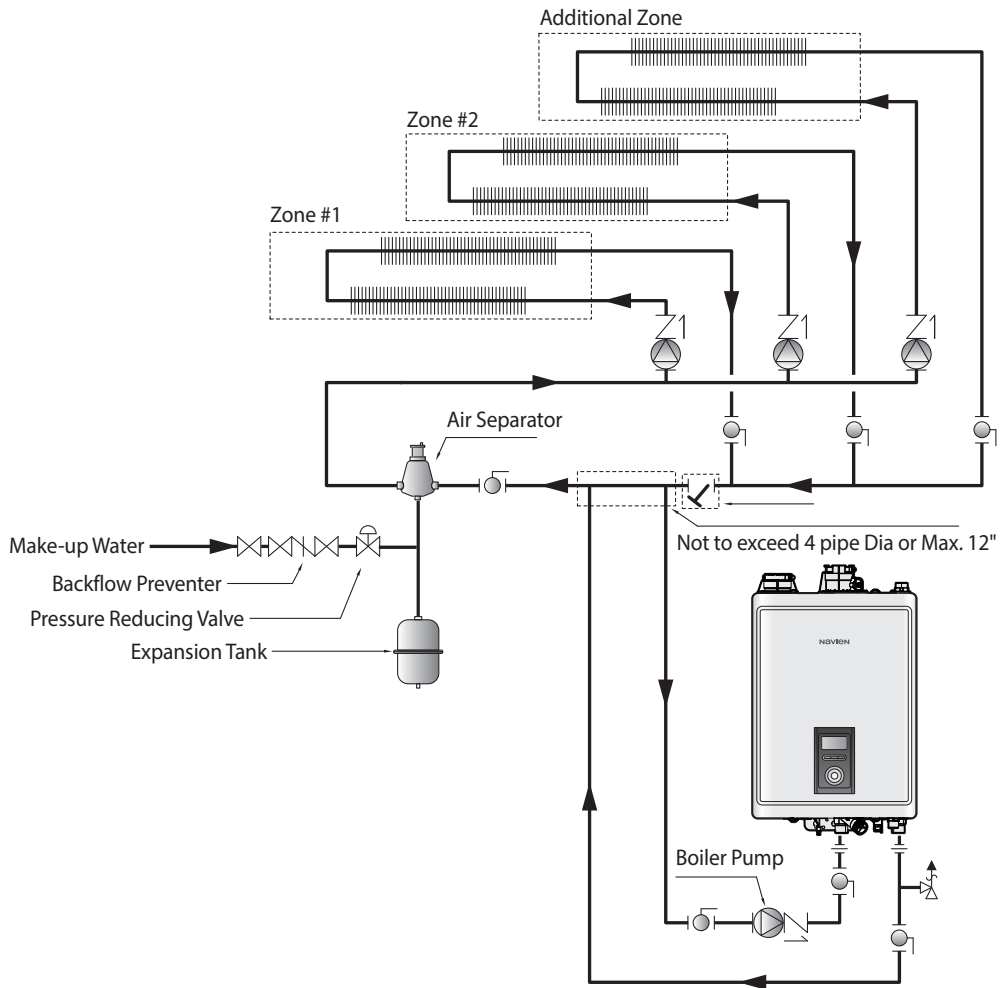

Note

- System application drawings are intended to explain the system piping concept only.
- Install a filter in the system return to remove foreign objects from the system. Foreign objects inside the system may result in abnormal system operation.
- Refer to “3.3 Filling the System” on page 26 for make-up water connections and refer to the requirements of your local codes to ensure compliance.
- Use a pump with an integral check valve or install a check valve at the pump outlet.
- Refer to “3.6.3 Wiring Diagram - Zone Pump System” on page 35 for wiring connections.

3.5.4 System Application - Air Handler System

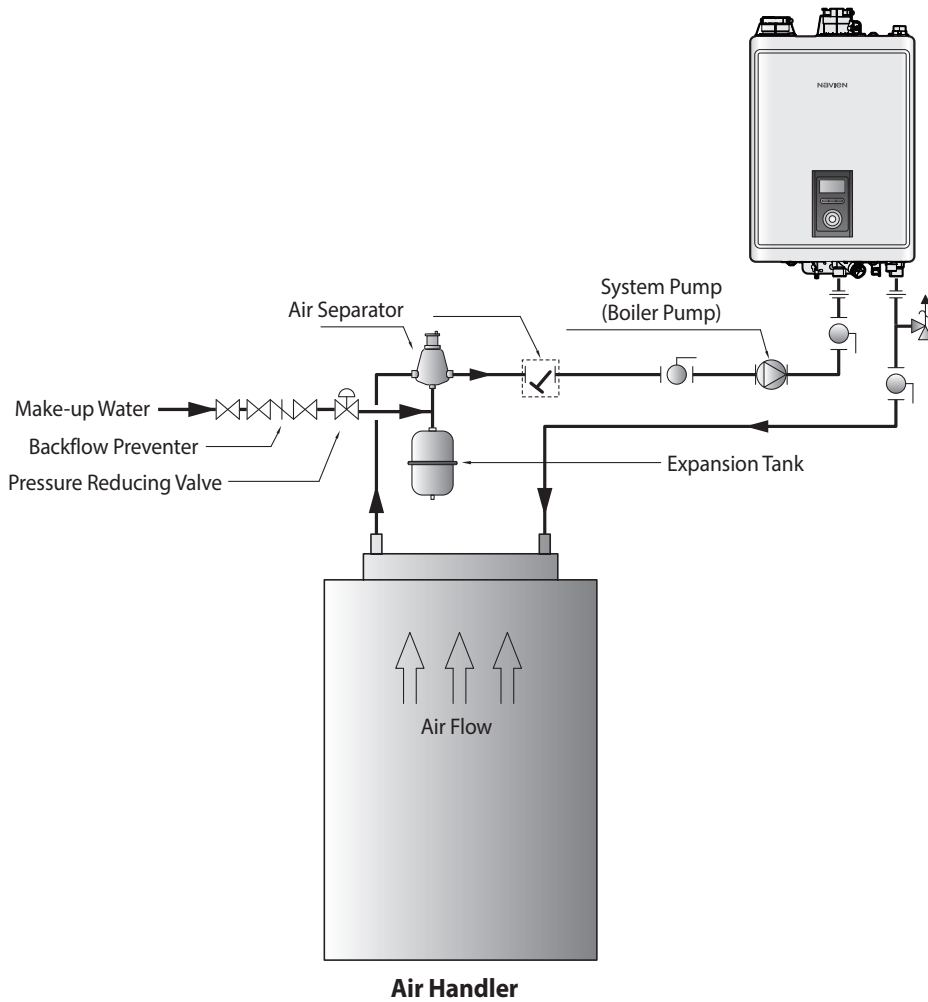

Note

- System application drawings are intended to explain the system piping concept only.
- Install a filter in the system return to remove foreign objects from the system. Foreign objects inside the system may result in abnormal system operation.
- Refer to “3.3 Filling the System” on page 26 for make-up water connections and refer to the requirements of your local codes to ensure compliance.
- Air handlers with an internal pump shall be piped either with a crossover pipe at the AHU or in a primary/secondary configuration with the boiler.
- Refer to the “3.6.9 Wiring Diagram - Air Handler” on page 43 for wiring connections.
- You can use a secondary piping configuration for the air handler system to maintain optimal flow and heat capacity.

3.5.5 System Application - DHW System with Indirect Tank (Primary/Secondary Piping)

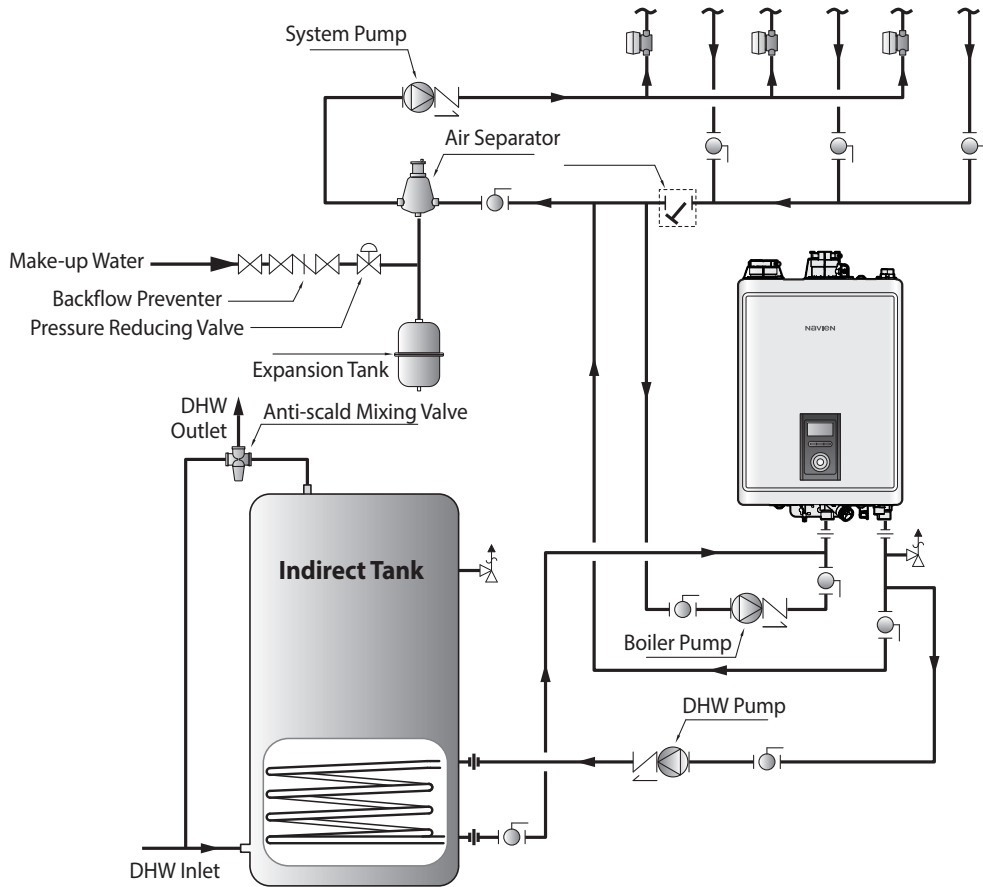

Note

- System application drawings are intended to explain the system piping concept only.
- Install a filter in the system return to remove foreign objects from the system. Foreign objects inside the system may result in abnormal system operation.
- Refer to “3.3 Filling the System” on page 26 for make-up water connections and refer to the requirements of your local codes to ensure compliance.
- Use a pump with an integral check valve or install a check valve at the pump outlet.
- Refer to the “3.6.10 Wiring Diagram - DHW System with Indirect Tank” on page 43 for wiring connections.

3.6 Examples of Electrical Connections

⚠ WARNING

Electric Shock Hazard

To prevent serious injury or death:

- ALWAYS follow all applicable electrical codes of the local authority having jurisdiction.
- In the absence of such requirements, follow the latest edition of the National Electrical Code (NFPA 70) in the USA or the latest edition of CSA C22.1 Canadian Electrical Code Part 1 in Canada.
- ONLY licensed professionals should connect the electrical components.
- ALWAYS label all wires before disconnecting them when you work on the controls.
- Wiring errors can cause improper and dangerous operation.
- ALWAYS verify proper operation after servicing.

Note

The installation must comply with National Electrical Code and any other national, state, provincial or local codes or regulations. In Canada, CSA C22.1 Canadian Electrical Code Part 1, and any local codes. Wiring must be N.E.C. Class 1. If original wiring as supplied with boiler must be replaced, use only type 105 °C wire or equivalent. Boiler must be electrically grounded as required by National Electrical Code ANSI/NFPA 70 – latest edition.

To access the PCB, carefully follow the steps below:

1. Turn off the power supply to the boiler.
2. Unfasten the 4 latches (2 at the top and 2 at the bottom) to remove the front cover and gain access to the internal components.



3.6.2 Wiring Diagram - External LWCO

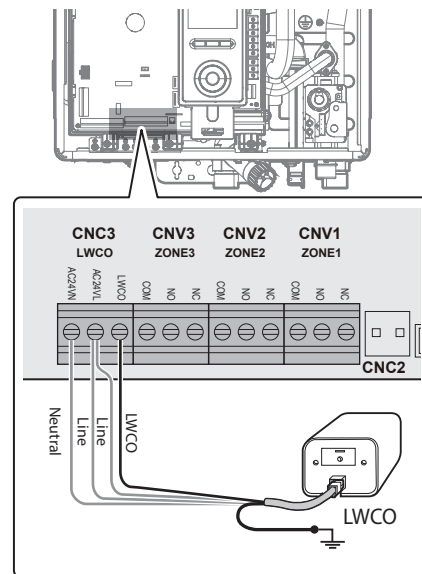

Note

The boiler supplies 24 VAC at the LWCO power terminals (CNC3).

3.6.1 Accessing the Terminal Strips

⚠ DANGER

Electric Shock Hazard

To prevent serious injury or death:

You must ensure that the boiler is disconnected from the electrical supply before carrying out any servicing inside the boiler and, particularly, on the electric terminal strips.

For terminal type LWCO devices, a typical wiring method is shown below (same voltage for control and burner circuit):

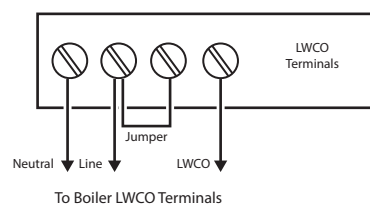

3.6.3 Wiring Diagram - Zone Pump System

The NHB-H boilers can operate a heating system with up to 3 zones. The following is the wiring diagram for a zone pump system with 3 zones.

Without 24VAC Connections

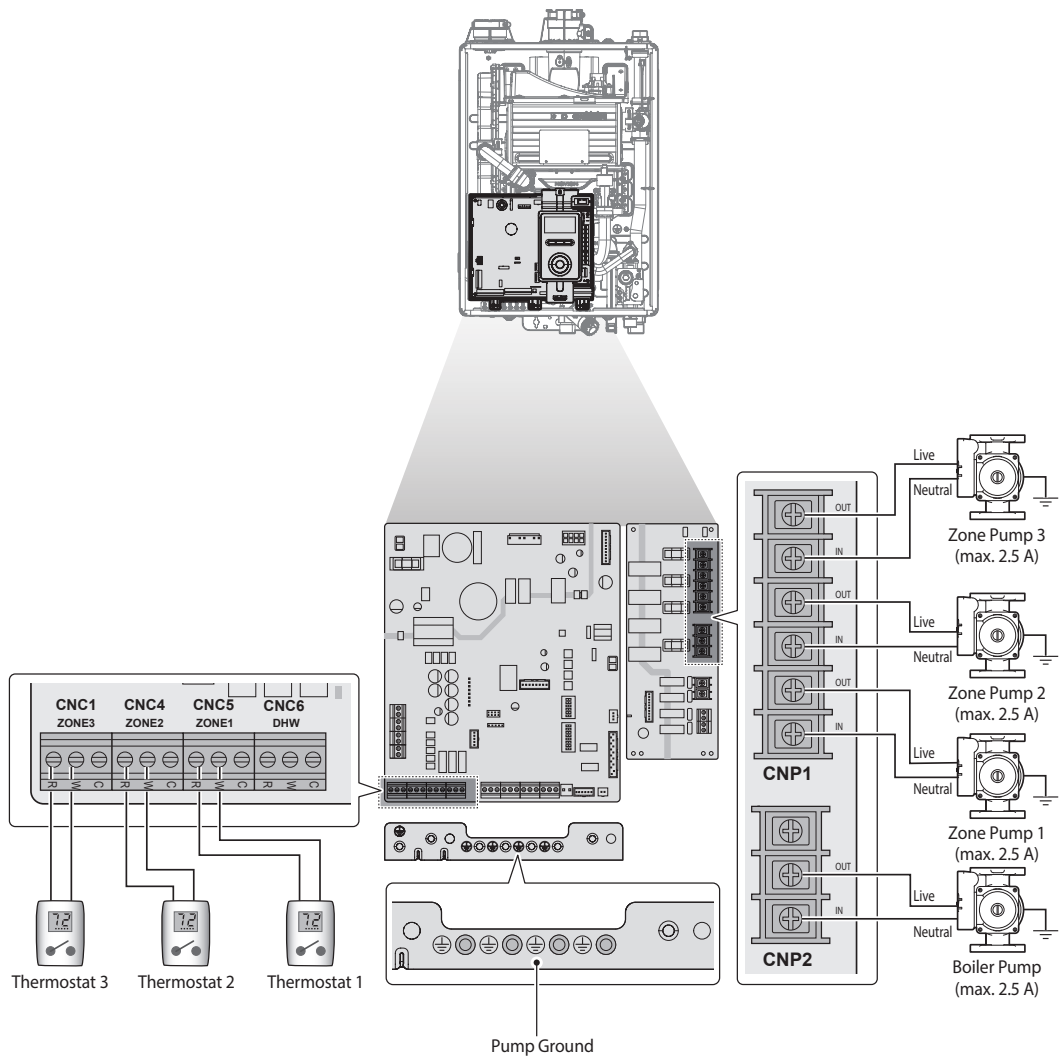

Note

- If you have a 24 V thermostat, connect it to the R & C terminals on the boiler's PCB.
- The C terminals are for optional connections with 24 V thermostat COMMON.

With 24VAC Connections

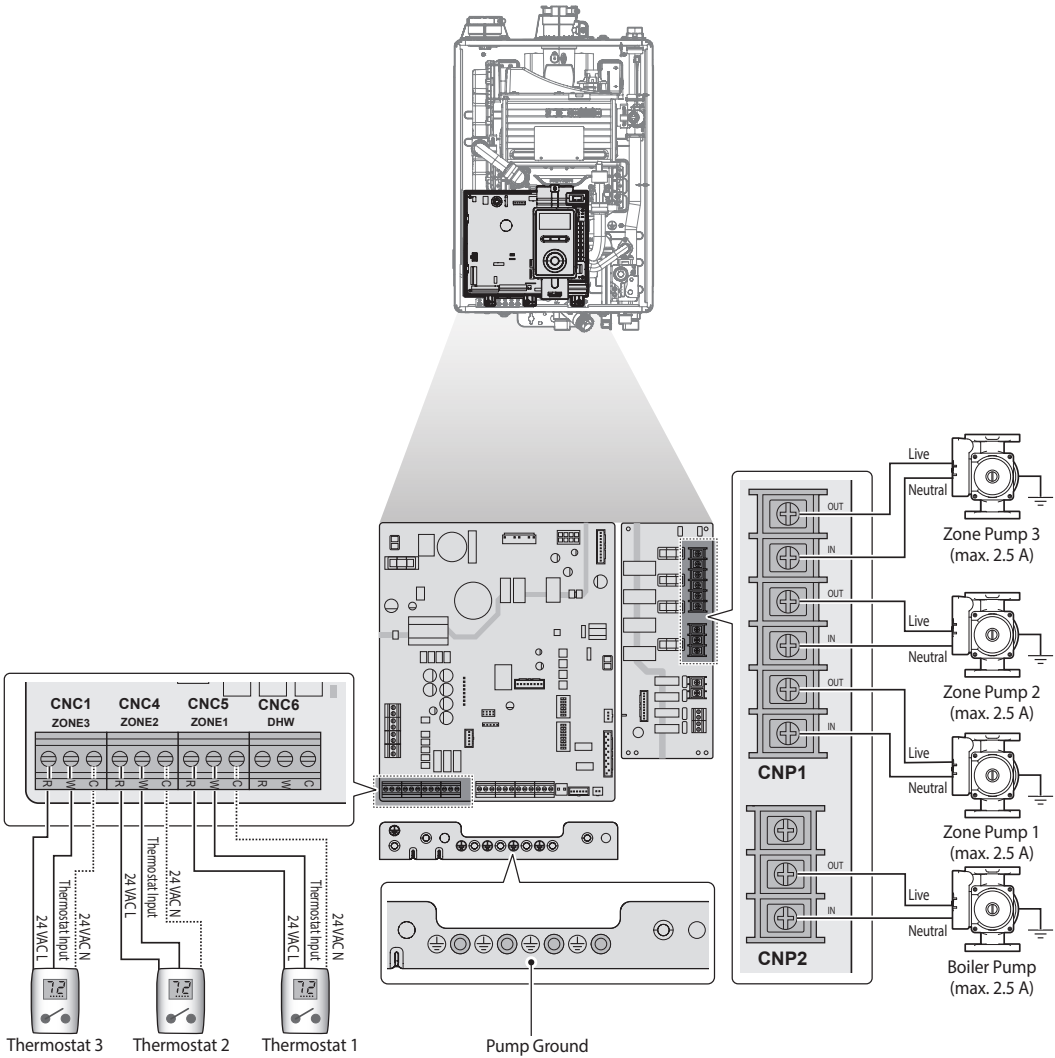

3.6.4 Wiring Diagram - Zone Pump System with DHW Tank

The NHB-H boilers can operate a heating system with up to 2 zones and 1 DHW Tank. The following is the wiring diagram for a zone pump system with 2 zones and 1 DHW Tank.

Without 24VAC Connections

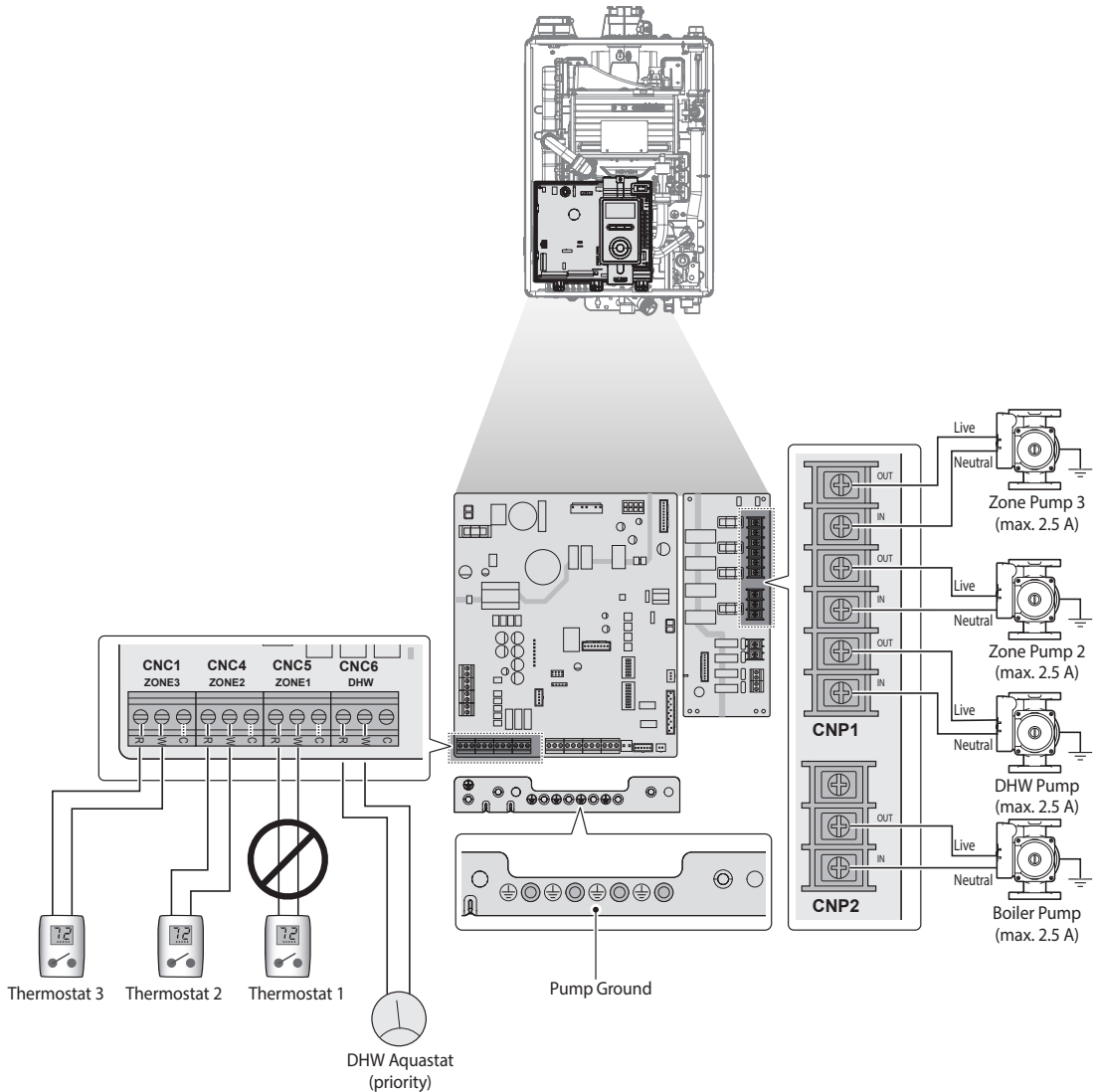

Note

- The C terminals are for optional connections with 24 V thermostat COMMON.
- If the DHW Tank is connected to the priority terminal, the T/S Zone 1 input is not available.

With 24VAC Connections

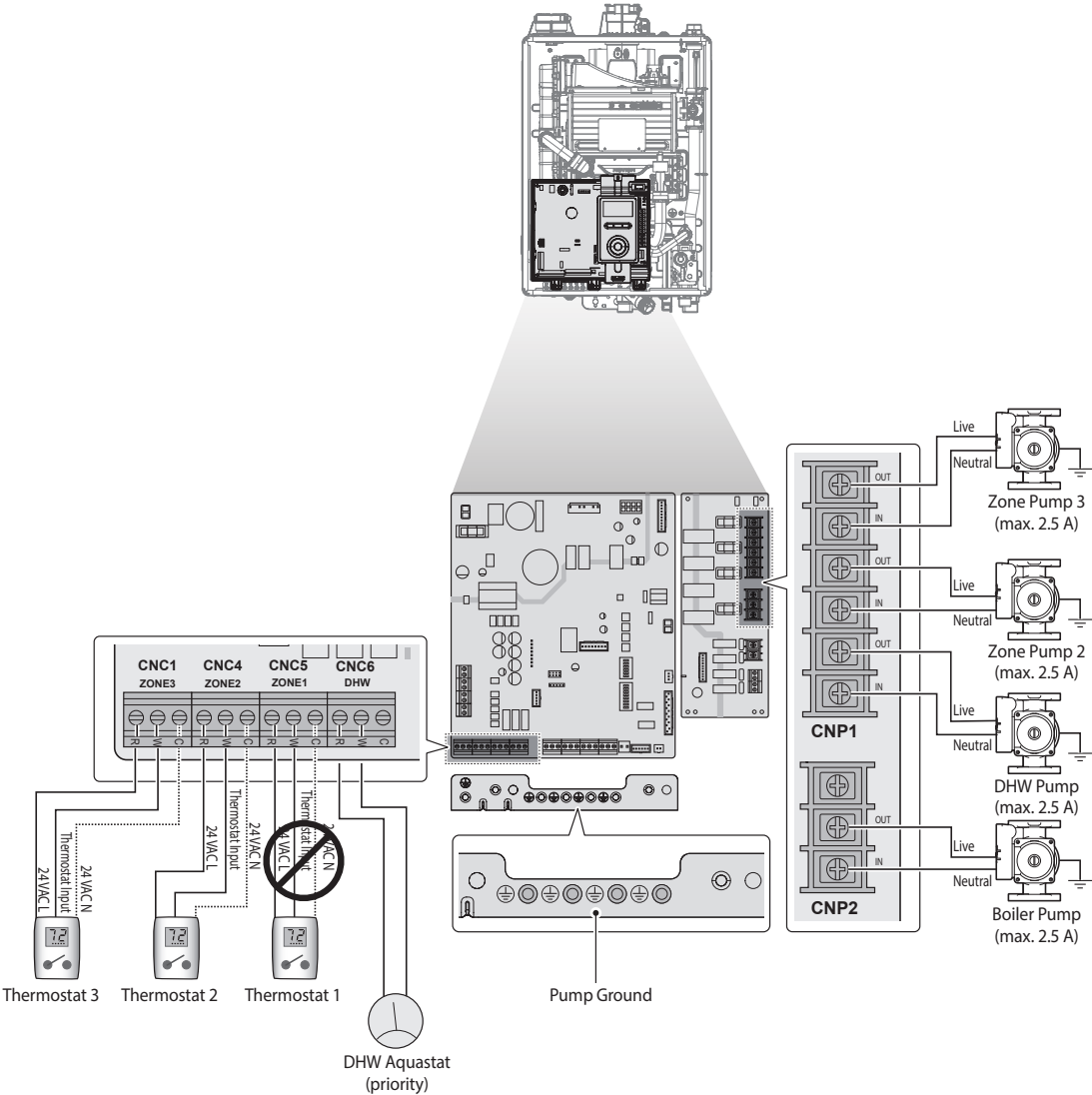

Note If the DHW Tank is connected to the priority terminal, the T/S Zone 1 input is not available.

3.6.5 Wiring Diagram - Zone Valve System

The NHB-H boilers can operate a heating system with up to 3 zones. The following is the wiring diagram for a zone valve system with 3 zones.

Without 24VAC Connections

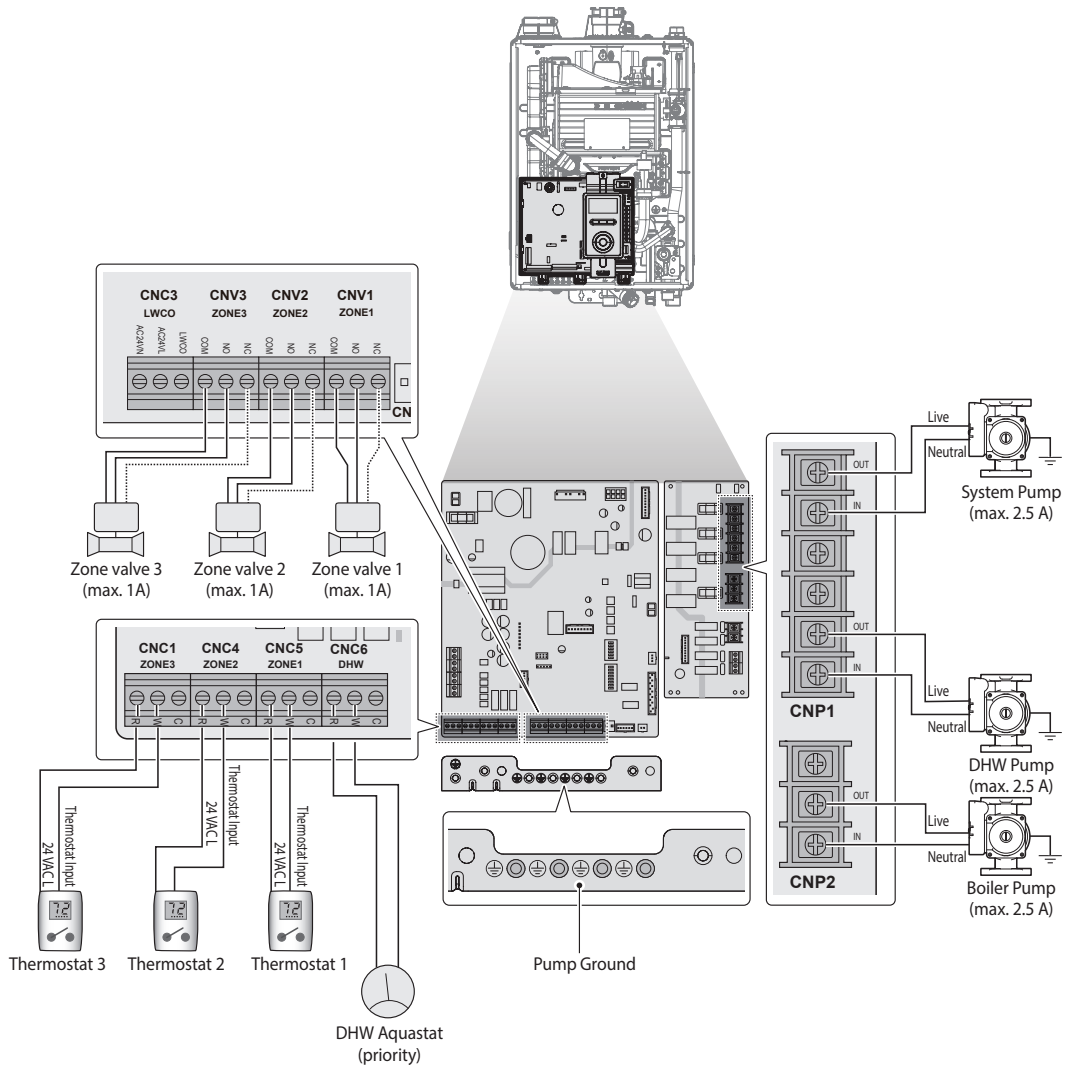

Note

- NO (Normal Open): Power is supplied when the zone valve is operating, and power turns off when the zone valve stops.
- NC (Normal Close): Power is supplied when the zone valve stops, and power turns off when the zone valve is operating.
- COM: 24 V AC COMMON
- The boiler has an internal 24V transformer that is rated for 75VA. This transformer provides power to the zone valve, low water cut-off (LWCO) and thermostat terminals.
- If the total power consumption of all 3 zone valves exceeds 72VA, an external zone valve controller must be used.

With 24VAC Connections

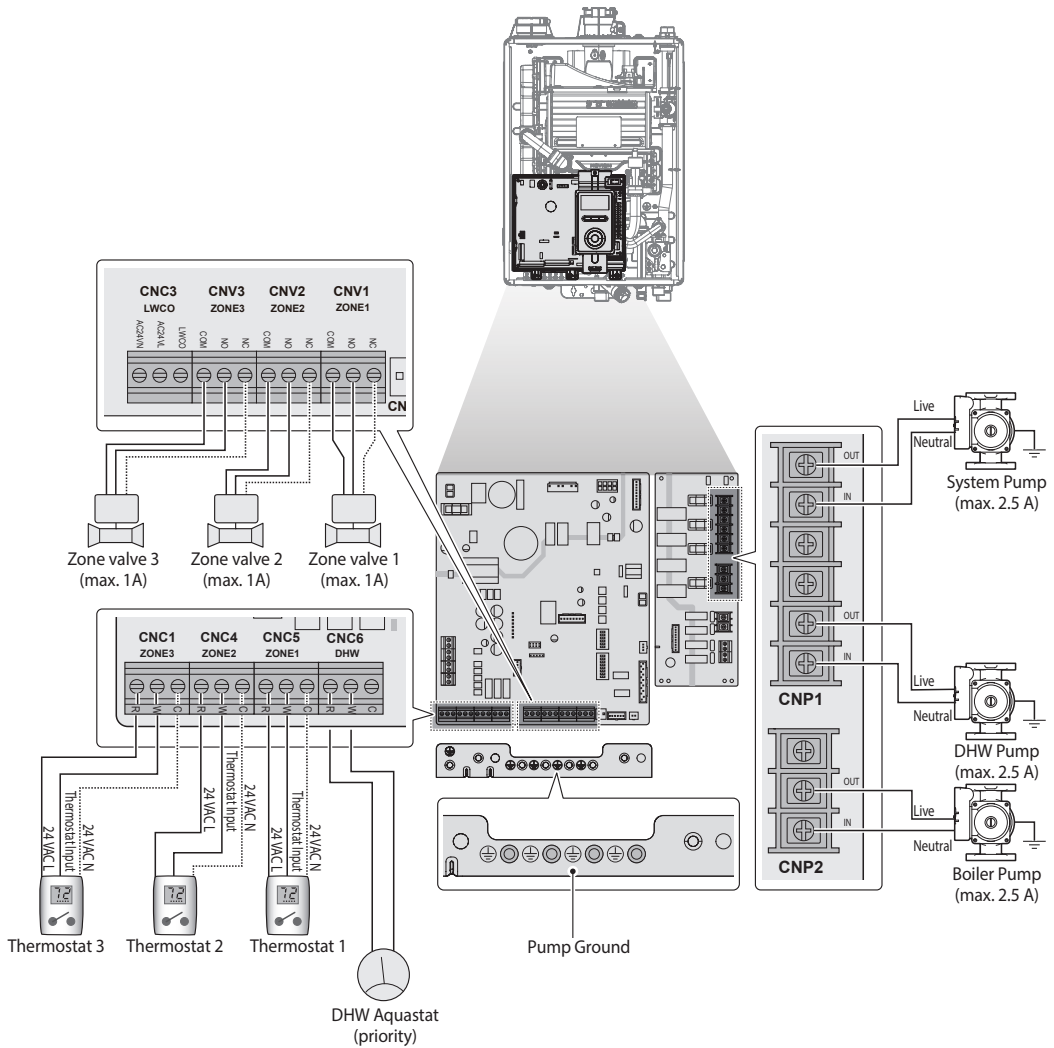

Note

- NO (Normal Open): Power is supplied when the zone valve is operating, and power turns off when the zone valve stops.
- NC (Normal Close): Power is supplied when the zone valve stops, and power turns off when the zone valve is operating.
- COM: 24 V AC COMMON
- The boiler has an internal 24V transformer that is rated for 75VA. This transformer provides power to the zone valve, low water cut-off (LWCO) and thermostat terminals.
- If the total power consumption of all 3 zone valves exceeds 72VA, an external zone valve controller must be used.

3.6.6 Wiring Diagram - the Navien Smartzone+

The Navien Smartzone+ controller may be used with the NHB-H boilers to operate a heating system with more than 3 zones.

When Navien boilers are used with a Navien Smartzone+ zone pump controller, an RS-485 data communication link is established through the Ready-link connection. This allows the controller and the boiler to share operational information and to control the zones more efficiently by minimizing unnecessary pump operation. The communication link also provides an optimal control environment for freeze protection.

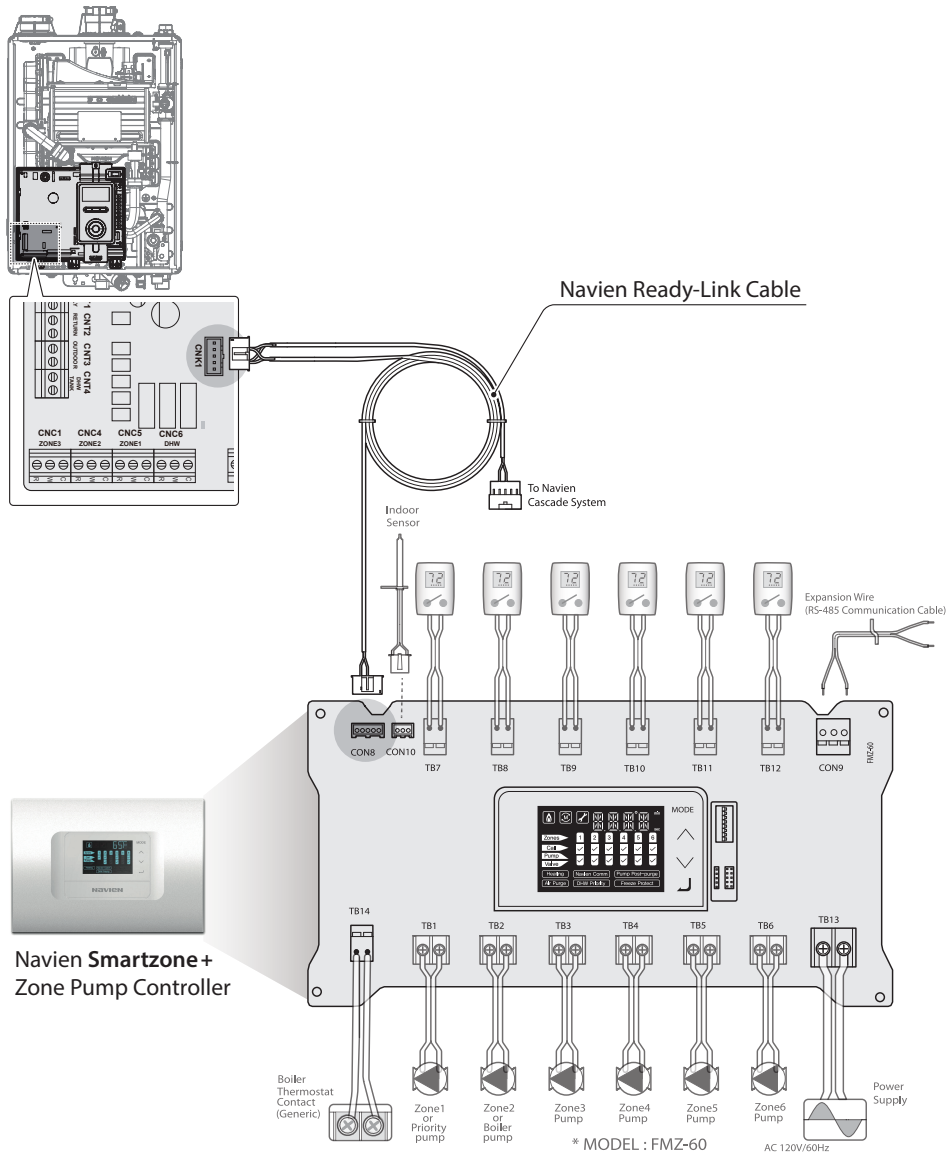

Refer to the user manual that is supplied with the Navien Smartzone+ zone pump controller for details.

Note The Navien Zone Controller setting must be enabled when using the Ready-Link cable for communication. Refer to "11.8 Setting the Space Heating Operation" on page 104 for details.

3.6.7 Wiring Diagram - Generic Zone System with Zone Valves

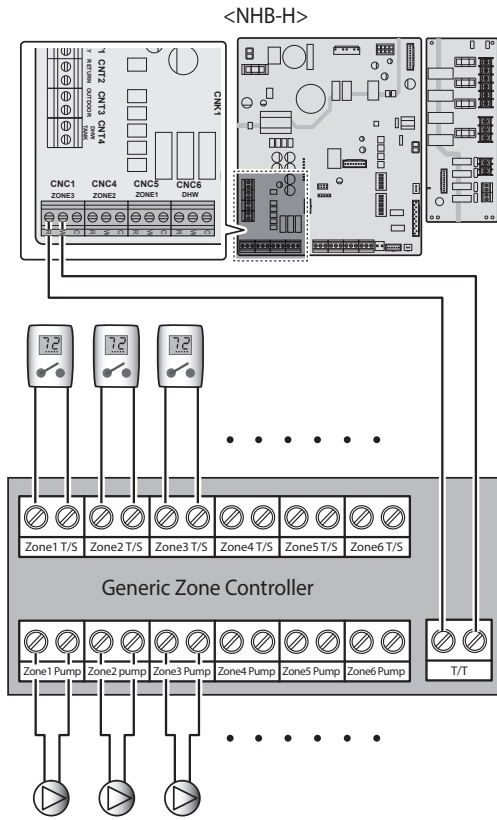

3.6.8 Wiring Diagram - Generic Zone System with Circulators

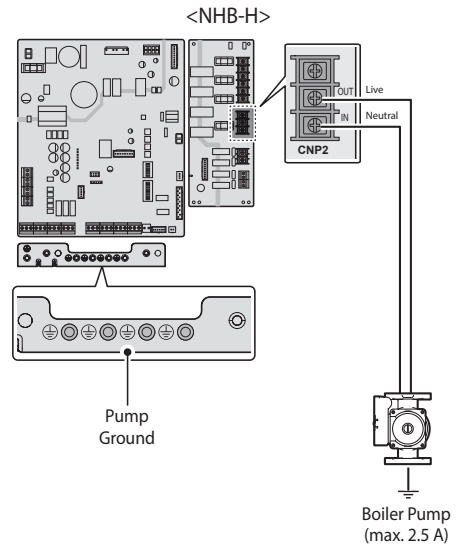
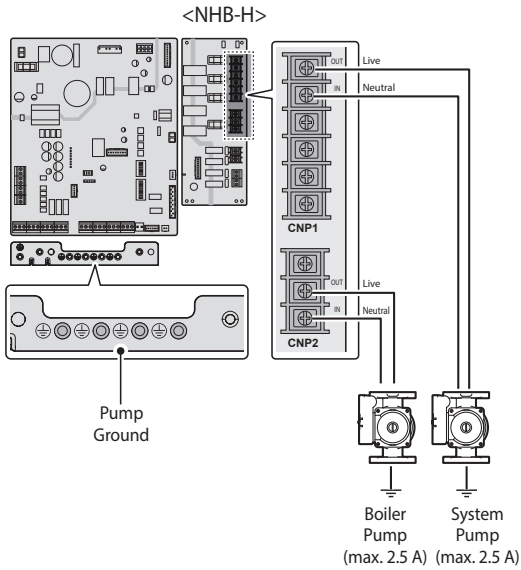
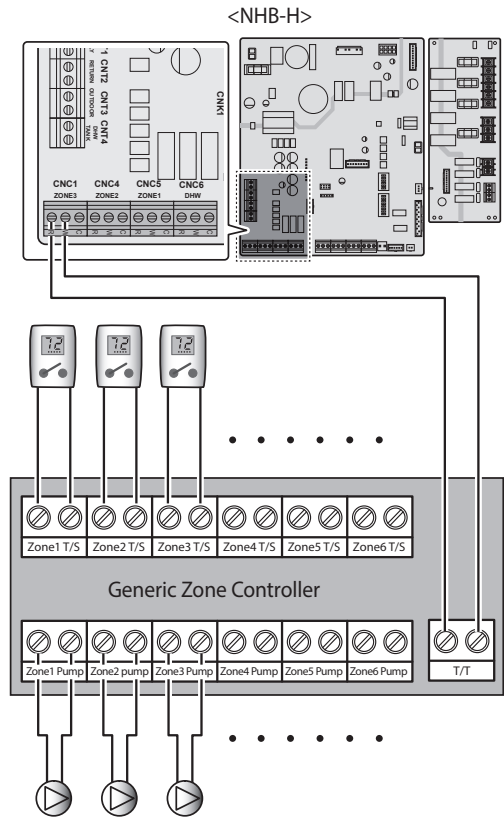

3.6.9 Wiring Diagram - Air Handler

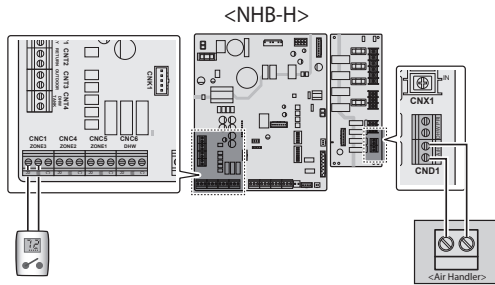

If you are using the Navien manifold system, connect the pump wires to the system pump. If you are not using the Navien manifold system, connect the pump wires to either the system pump or the boiler pump.

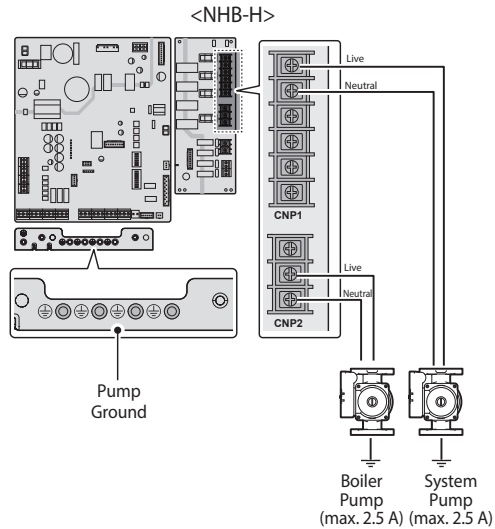

3.6.10 Wiring Diagram - DHW System with Indirect Tank

When connecting the Aquastat

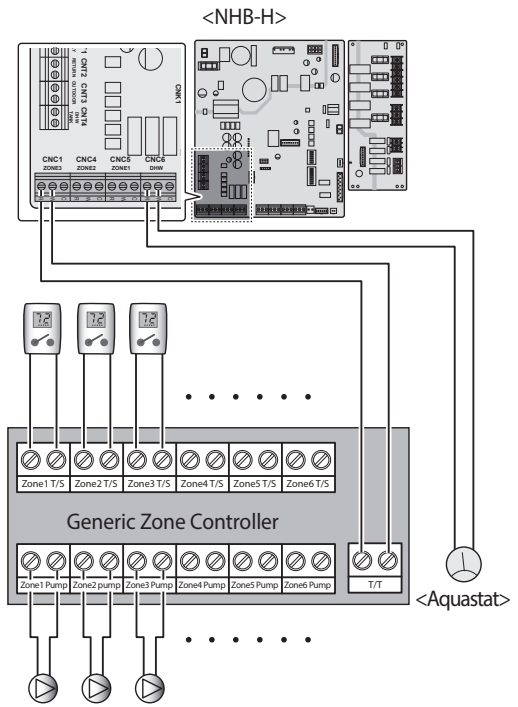

When connecting the DHW Tank Sensor

The Navien Universal Temperature sensor can be used as a DHW Tank Sensor. When installing the Universal Temperature sensor to the boiler, follow these guidelines:

- This sensor is compatible for use with aquastat immersion wells. Attach an aquastat immersion well to the DHW tank before installing the sensor.
- When installing the sensor to the tank, verify that the sensor is completely inserted into the immersion well.
- Install the included clip on the groove on the immersion well as shown in the illustration.
- Insert the wire through the available eyelet on the clip then wrap it around the clip once to fix the sensor to the well.
- Complete the installation by connecting the wires to the DHW Tank terminals located on the PCB.

Note When inserting the sensor into the immersion well, heat conductive paste can be used to improve thermal transfer between the two components.

Installing the DHW Tank Sensor

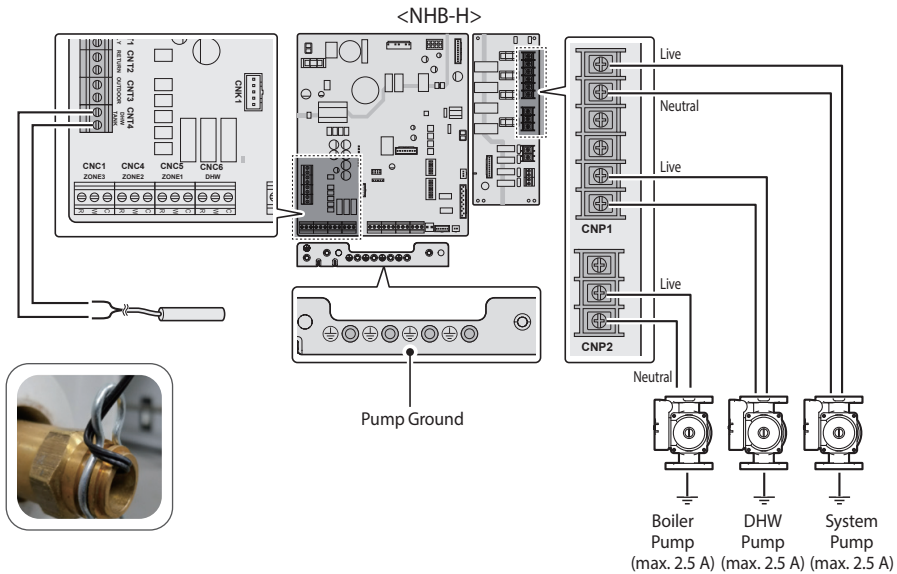

NOTICE

Use only the Navien Universal Temperature sensor (#GXXX001769). The use of other sensors may result in higher water temperatures than expected.

3.6.11 Wiring Diagram - Optional Supply/Return Temperature Sensors

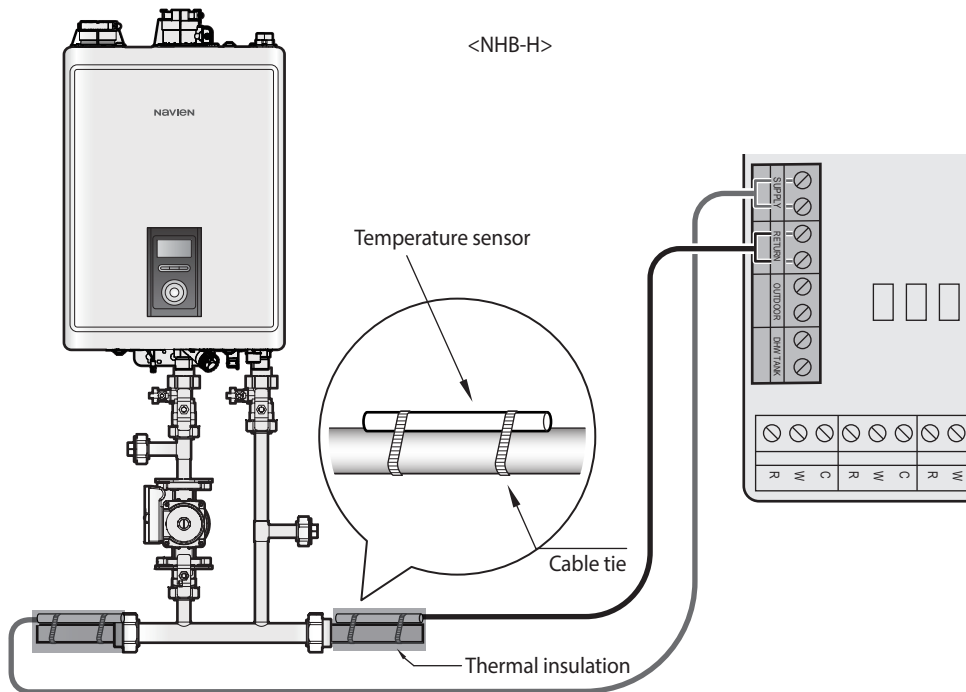

Note

- To control the boiler supply or return water temperature using the external temperature sensors, configure the system accordingly.
- On the front panel, press the Menu button (M) to enter the setting menu, and then select 2. Space Htg Operation > 6. SH Control Method to select one of the control modes.
- Use only the Navien Universal Temperature sensor (#GXXX001769). The use of other sensors may result in higher water temperatures than expected.

4. Connecting the Gas Supply

⚠ WARNING

To prevent death, serious injury or property damage:

- ALWAYS check the Rating Plate located on the side of the product matches the gas type, gas pressure, water pressure, and electrical supply available for the unit.
- CHECK the #1 DIP switch setting on the Front panel matches the type of gas supplied to the unit (OFF for Natural Gas and ON for Propane Gas).

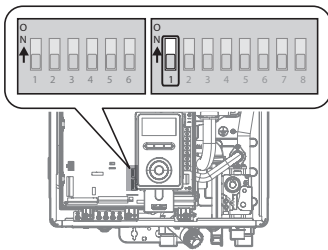

Switch	Function	Setting	
1	Gas Type	Natural Gas	1-OFF
		Propane Gas	1-ON

- Before connecting the gas supply, determine the gas type and pressure for the boiler by referring to the rating plate. Use only the same gas type indicated on the rating plate. Using a different gas type will result in abnormal combustion and malfunction of the boiler. Gas supplies should be connected by a licensed professional only.
- To avoid damaging the connectors on the boiler, use two wrenches when tightening piping to the boiler. Use one wrench to prevent the boiler's connector from turning, and use the other wrench to tighten the connection. Damaged connectors may result in system leaks.
- Properly support the piping with hangers. Do not allow the piping to be supported by the boiler or its accessories.

⚠ WARNING

- Ensure that the gas piping is protected from physical damage and freezing where required. Failure to follow these instructions could result in gas leakage and result in fire, explosion, property damage, severe personal injury, or death.
- The appliance and its gas connection must be leak tested before placing the appliance in operation.
- To avoid danger from explosion and fire, do not use a flame to check for a gas leak. Perform a bubble test on the joints to check for gas leaks. If a leak exists, bubbles will form at the leaking joint. A gas leak could result in substantial property damage, severe personal injury, or death.
- Immediately turn off the boiler and stop the gas supply if a gas leak is detected. Perform a bubble test to find the leak and repair the leak immediately. Do not start the boiler again until the leak is repaired. Operating the boiler with a gas leak could result in substantial property damage, severe personal injury, or death.
- This boiler cannot be converted from natural gas to propane or vice versa without a Navien gas conversion kit. Do not attempt a field conversion of this boiler without a Navien gas conversion kit. Doing so will result in dangerous operating conditions and will void the warranty.

Navien recommends connecting the boiler as the first appliance downstream of the gas meter, to ensure a sufficient gas supply.

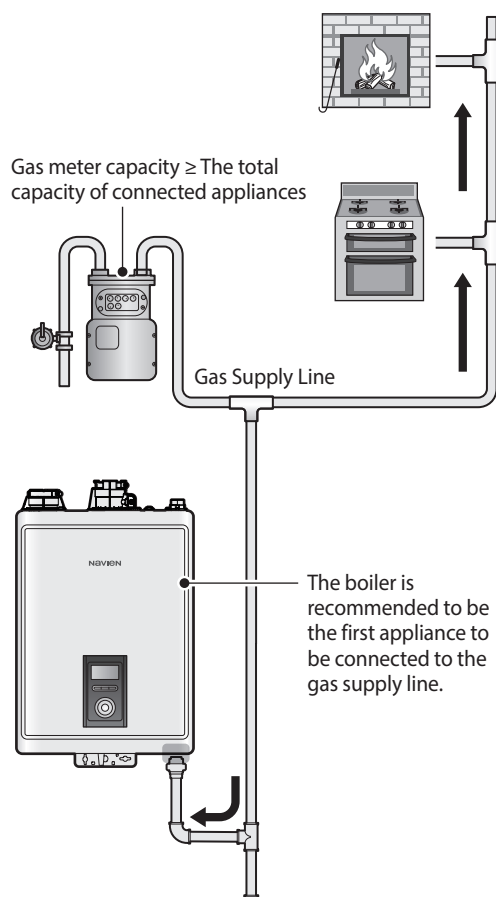

6. Connect the gas supply line.
7. Test the supply line, all connection points, and the boiler for gas leaks.

Note Tighten the boiler connection valves with care to avoid damage.

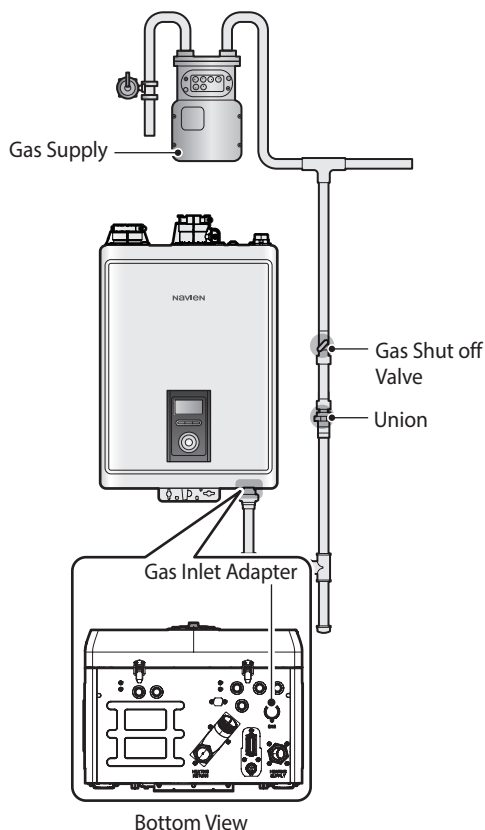

To connect the gas supply:

1. Determine the gas type and pressure for the boiler by referring to the rating plate.
2. Perform a pressure test on the main gas supply line.
3. Purge the gas line of any debris.
4. Determine the proper size and type for the gas line. Refer to the tables that follow.

Note Refer to the instructions provided with the gas regulator for the minimum pipe distance between the regulator and the appliance.

5. Install certified full port valves on the gas supply line and boiler.

NOTICE

- Install a manual gas shut-off valve between the gas supply line and the boiler.
- A sediment trap must be provided upstream of the gas controls.

Note

- Tighten the boiler connection valves with care to avoid damage.
- The gas connection fitting on all boilers is 3/4 in.
- 1/2 in rigid pipe can be used; refer to the sizing tables on the proceeding pages for limitations. Do not use 1/2 in corrugated connectors or tubing as noise may occur.



Corrugated Connector

- When using flexible gas lines, ensure that the pipe's inner diameter and connector is sufficient to supply the required BTUs. Also, ensure that the flexible line has no crimps or tight bends in it, as this will restrict gas flow.
- When using rigid pipe, Navien recommends the installation of a union on the gas supply line close to the boiler, to facilitate any future maintenance or service.

NOTICE

Prior to using an excess flow valve (EFV) in the gas line, check the manufacturer's minimum and maximum flow capacity rating. An improperly sized EFV will not allow for a full flow of gas to the boiler and may cause improper operation.

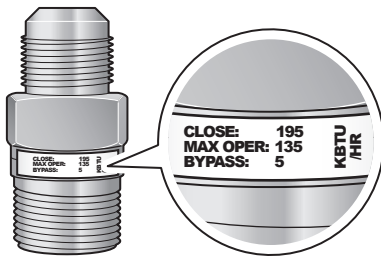

Excess Flow Valve

Typical LP Gas piping examples:

2 Stage System with Multiple Regulators (Recommended)

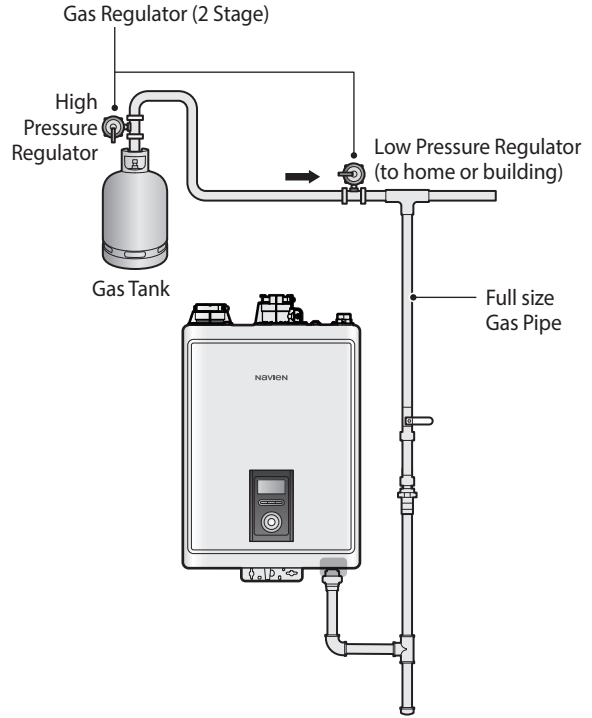

Single Regulator System

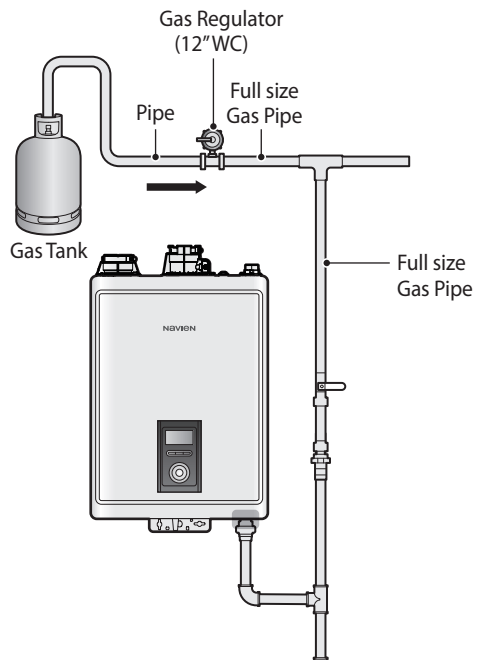

4.1 Gas Pipe Sizing Tables

The following tables are referenced from the 2021 National Fuel Gas Code and are for reference only. Please consult the gas pipe manufacturer for actual pipe capacities.

Maximum Natural Gas Delivery Capacity

In Cubic Feet (ft³) per Hour (0.60 Specific Gravity; 0.5 in WC Pressure Drop). Contact your gas supplier for BTU/ft³ ratings. Use 1,000 BTU/ft³ for simplified calculations. This table is recommended for supply pressures less than 6 in WC.

Pipe Size	Length (including fittings)										
	10 ft (3 m)	20 ft (6 m)	30 ft (9 m)	40 ft (12 m)	50 ft (15 m)	60 ft (18 m)	70 ft (21 m)	80 ft (24 m)	90 ft (27 m)	100 ft (30 m)	125 ft (38 m)
¾ in	360	247	199	170	151	137	126	117	110	104	92
1 in	678	466	374	320	284	257	237	220	207	195	173
1 ¼ in	1,390	957	768	657	583	528	486	452	424	400	355
1 ½ in	2,090	1,430	1,150	985	873	791	728	677	635	600	532
2 in	4,020	2,760	2,220	1,900	1,680	1,520	1,400	1,300	1,220	1,160	1,020
2 ½ in	6,400	4,400	3,530	3,020	2,680	2,430	2,230	2,080	1,950	1,840	1,630
3 in	11,300	7,780	6,250	5,350	4,740	4,290	3,950	3,670	3,450	3,260	2,890
4 in	23,100	15,900	12,700	10,900	9,660	8,760	8,050	7,490	7,030	6,640	5,890

In Cubic Feet (ft³) per Hour (0.60 Specific Gravity; 3.0 in WC Pressure Drop). Contact your gas supplier for BTU/ft³ ratings. Use 1,000 BTU/ft³ for simplified calculations. This table is recommended for supply pressures of 6 in WC or greater.

Pipe Size	Length (including fittings)										
	10 ft (3 m)	20 ft (6 m)	30 ft (9 m)	40 ft (12 m)	50 ft (15 m)	60 ft (18 m)	70 ft (21 m)	80 ft (24 m)	90 ft (27 m)	100 ft (30 m)	125 ft (38 m)
½ in	454	312	250	214	190	172	158	147	138	131	116
¾ in	949	652	524	448	397	360	331	308	289	273	242
1 in	1,790	1,230	986	844	748	678	624	580	544	514	456
1 ¼ in	3,670	2,520	2,030	1,730	1,540	1,390	1,280	1,190	1,120	1,060	936
1 ½ in	5,500	3,780	3,030	2,600	2,300	2,090	1,920	1,790	1,670	1,580	1,400
2 in	10,600	7,280	5,840	5,000	4,430	4,020	3,690	3,440	3,230	3,050	2,700
2 ½ in	16,900	11,600	9,310	7,970	7,060	6,400	5,890	5,480	5,140	4,860	4,300
3 in	29,800	20,500	16,500	14,100	12,500	11,300	10,400	9,690	9,090	8,580	7,610
4 in	60,800	41,800	33,600	28,700	25,500	23,100	21,200	19,800	18,500	17,500	15,500

Maximum Liquefied Propane Delivery Capacity

In Thousands of BTU/H (0.5 in WC pressure drop)

Pipe Size	Length (including fittings)												
	10 ft (3 m)	20 ft (6 m)	30 ft (9 m)	40 ft (12 m)	50 ft (15 m)	60 ft (18 m)	70 ft (21 m)	80 ft (24 m)	90 ft (27 m)	100 ft (30 m)	125 ft (38 m)	150 ft (45 m)	175 ft (53 m)
½ in	291	200	160	137	122	110	101	94	89	84	74	67	62
¾ in	608	418	336	287	255	231	212	197	185	175	155	140	129
1 in	1,150	787	632	541	480	434	400	372	349	330	292	265	243
1 ¼ in	2,350	1,620	1,300	1,110	985	892	821	763	716	677	600	543	500
1 ½ in	3,520	2,420	1,940	1,660	1,480	1,340	1,230	1,140	1,070	1,010	899	814	749
2 in	6,790	4,660	3,750	3,210	2,840	2,570	2,370	2,200	2,070	1,950	1,730	1,570	1,440

4.2 Measuring the Inlet Gas Pressure

WARNING

The boiler cannot function properly without sufficient inlet gas pressure. Measuring the inlet gas pressure should be performed by a licensed professional only.

- The inlet gas pressure must be maintained between 3.5 in and 10.5 in WC for natural gas and between 8.0 in and 13.0 in WC for liquefied propane.
- The appliance and its individual shutoff valve must be disconnected from the gas supply piping system during any pressure testing of that system at test pressures in excess of ½ psi (3.5 kPa).
- The appliance must be isolated from the gas supply piping system by closing its individual manual shutoff valve during any pressure testing of the gas supply piping system at test pressures equal to or less than ½ psi (3.5 kPa).

To measure the inlet gas pressure:

1. Shut off the manual gas valve on the gas supply line.

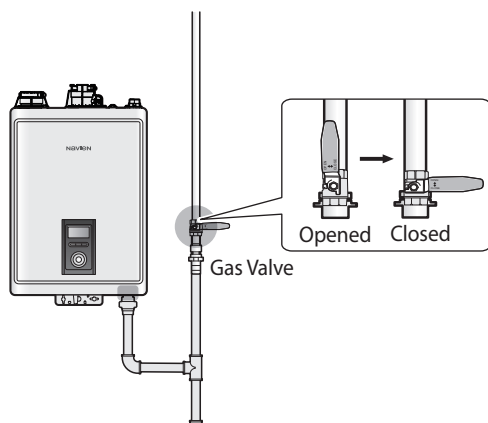

2. Turn on the boiler. On the front panel, press the Back button (↩) and the Menu button (M) simultaneously for 3 seconds, and then rotate the Command dial (⊙) to move to **7. Special Operations**.

3. Press the Command dial (⊙) to enter special operation mode.

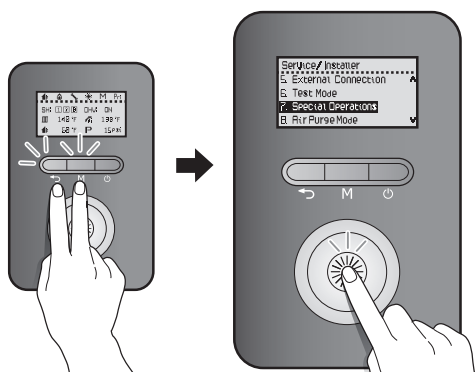

4. Rotate the Command dial (⊙) to move to **5. 2nd Max**, and then press the command dial (⊙) to select the operation mode.
5. Press the Back button (↩) twice to return to normal operation mode.
6. Run space heating. The gas in the gas supply line will be purged.
7. Leave the boiler on until the boiler shuts down due to a lack of gas supply, and then turn off the boiler.

8. Unfasten the 4 latches (2 at the top and 2 at the bottom) to remove the front cover and gain access to the internal components.

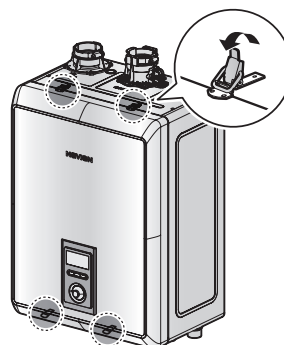

9. Loosen the screws indicated in the figure below and connect a manometer to the pressure port. Reset the manometer to zero before use.

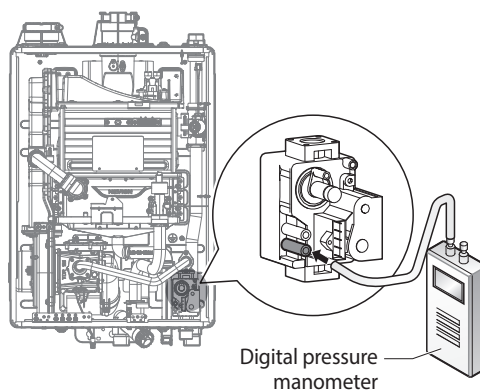

10. Re-open the manual gas valve and check for leaks.
11. Activate multiple zones to ramp the boiler up to its maximum firing rate.
12. When the boiler reaches its maximum firing rate, check the inlet gas pressure reading on the manometer. The gas pressure must fall within the ranges specified on page 6.

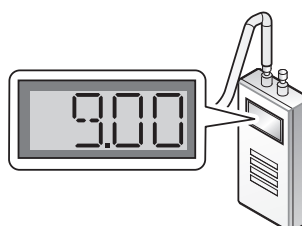

5. Venting for Combustion Air

Additional Guidelines for Combustion Air

WARNING

Carbon Monoxide Hazard

The installation of carbon monoxide detectors may be required in your area for the boiler or other gas fired appliances. Check applicable codes for the installation location of the boiler.

Carbon monoxide detectors should comply with NFPA 720 and be ANSI/UL 2034 listed and IAS certified.

- Combustion air piping to the outside is recommended. (Direct Venting)
- The boiler may be installed with a single pipe carrying the flue products to the outside while using combustion air from the equipment room. In order to use the room air venting option on page 58, specific conditions and considerations must be followed.

WARNING

To prevent death, serious injury, or property damage:

- Do not install the boiler or combustion air piping in areas with contaminated air (containing a high level of dust, sawdust, sand, flour, aerosols, fluorine or chlorine compounds), as contaminants can cause severe problems.
- Pool and laundry products and common household cleaning products can contain corrosive compounds. If any of the chemicals or vapors enter the boiler, this can result in serious product damage that can even cause the potential for flue gas leakage in extreme cases.

To prevent the potential of severe personal injury or death, check for areas and products listed in the following tables before installing the boiler or air inlet piping.

If contaminants are found in the combustion air, you MUST Remove contaminants permanently or Relocate air inlet and vent terminations to other clean areas.

- If you must install the boiler in an area with contaminated air, use direct venting to supply clean air from outside the building. We recommend regular filter cleaning and maintenance in these areas.

Note

The warranty does not cover damage caused by air contaminants.

Corrosive Contaminants
Muriatic acid/hydrochloric acid
Refrigerant leaks
Chlorine-type bleaches, detergents, and cleaning solvents found in household laundry rooms
Varnish removers or paint
Adhesives used to fasten building products and other similar products
Chlorine-based swimming pool chemicals
Permanent wave solutions
Anti-static fabric softeners used in clothes dryers
Calcium chloride used for thawing
Spray cans containing chloro/fluorocarbons
Cements and glues
Sodium chloride used for water softening
Chlorinated waxes/cleaners

Corrosive Sources
Remodeling areas
Refrigeration repair shops
New building construction
Metal fabrication plants
Laundry areas and establishments/dry cleaning
Swimming pools
Auto body shops
Furniture refinishing areas and establishments
Garages with workshops
Plastic manufacturing plants
Beauty shops
Photo processing plants

5.1 Venting the Boiler

DANGER

This appliance is certified as a Category IV appliance and requires a special venting system. The vent system operates with a positive pressure in the pipe.

To prevent serious injury or death:

- ALWAYS vent exhaust gases directly outdoors using the vent materials and following these instructions.
- DO NOT connect vent connectors serving appliances vented by natural draft into any portion of mechanical draft systems operating under positive pressure.

WARNING

Improper venting of the boiler can result in excessive levels of carbon monoxide and can lead to serious injury or death.

This boiler must be vented in accordance with the “Venting of Equipment” section of the latest edition of the ANSI Z223.1/NFPA 54 Natural Fuel Gas Code in the USA and/or the “Venting systems and air supply for boilers” section of the latest version of the CAN/CGA B149.1 Natural Gas and Propane Installation Code in Canada, as well as all applicable local building codes and regulations.

To prevent serious injury or death:

- ONLY licensed professionals should install venting.
- ALWAYS follow all regulations, codes, and instructions when venting the boiler.
- ALWAYS seal the venting system gastight to prevent flue gas leakage and carbon monoxide emissions.
- The building owner is responsible to maintain the exhaust and intake terminations free of snow, ice, or other potential blockages, as well as scheduling routine maintenance.
- ALWAYS seal the venting system gastight to prevent flue gas leakage and carbon monoxide emissions.
- The building owner is responsible to maintain the exhaust and intake terminations free of snow, ice, or other potential blockages, as well as scheduling routine maintenance.

The boiler must be properly vented to ensure a constant supply of clean intake air and to ensure that exhaust air is properly removed from living areas. When venting the boiler, follow these guidelines:

- Do not install the boiler in areas with contaminated air (containing a high level of dust, sawdust, sand, flour, aerosols, or any other such airborne contaminants), as contaminants can cause operational problems. The warranty does not cover damage caused by contaminants in the installation area. If you must install the boilers in an area with contaminated air, use direct venting to supply air from outside the building. We recommend regular filter cleaning and maintenance in these areas.
- For best results, keep the venting system as short and straight as possible.
- Locate the boiler as close as possible to the vent termination.
- Do not connect the boiler vent to a vent for any other gas boiler or vent stack.
- For horizontal runs, slope the horizontal section upward toward the vent termination at a rate of $\frac{1}{4}$ in per foot (2% slope).
- Create an airtight seal at each joint in the exhaust and intake air pipes from the boiler collar to the vent termination (see below).

Note

Do not cover any non-metallic vent materials with thermal insulation.

Connecting the Pipe to the Vent Collar

Note Do not use primer or cement on the appliance connection.

⚠ WARNING

ALWAYS properly cut the pipe at a 90° angle and deburr the vent pipe before installing so the pipe is fully connected to the exhaust gas vent fitting.

Use water (NOT grease) to lubricate the end of the vent pipe before inserting into the collar.

ALWAYS insert the vent pipe 2-3/4" (70mm) into the appliance exhaust collar using a twisting motion until the end reaches the bottom of the socket.

If flue gas leaks, inhalation of carbon monoxide may result in serious injury or death.

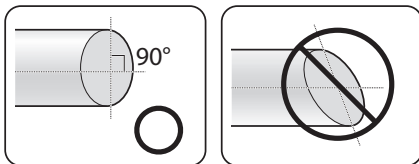
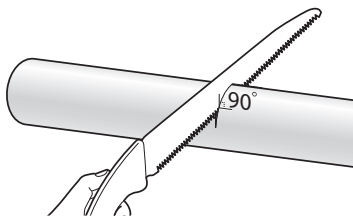

1. Measure 2-3/4" (70mm) from the end of the vent pipe, then draw a mark at that distance.

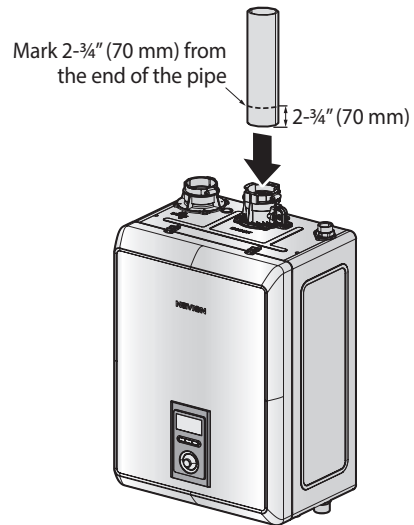

2. Insert the pipe into the vent collar to start the vent run. Make sure to completely slide the vent into the collar until the end makes contact with the bottom of the socket.

Note Verify that 2-3/4" (70 mm) of the pipe has been completely inserted into the collar and that the mark is no longer visible.

3. Tighten the clamp with a socket wrench (8 mm) to properly seal the joint.

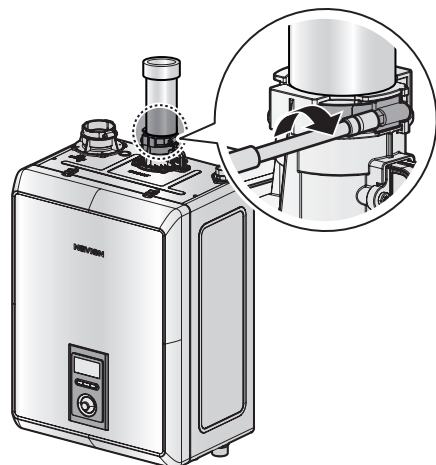

⚠ WARNING

NEVER start the vent run with a **street elbow** at the vent collar to prevent serious injury or death. Using an elbow directly at the collar will not allow for a tight seal between the appliance and the vent pipe.

ALWAYS use a length of straight pipe when starting the vent run.



- To avoid moisture and frost build-up and to maintain clearances to openings on adjacent homes, 45° elbows, 90° elbows, or tees may be attached to the end of the termination vent pipe to direct the exhaust plumes away from buildings, as long as the total allowable vent lengths, maximum number of elbows, and distances to air intake restrictions are observed.
- Do not store hazardous or flammable substances near the vent termination.
- If this boiler will be installed in areas where snow is known to accumulate, protect the vent termination from blockage.
- Ensure that the vent termination is at least 12 in (300 mm) above the highest anticipated snow line, or as required by local codes, whichever is greater.
- Support the vent pipe with hangers at regular intervals or as required by local codes.
Exhaust and intake air pipes must be supported at least every 4 ft (1.2 m).
- The vent for this appliance shall not terminate over public walkways; or near soffit vents or crawl space vents or a nuisance or hazard or cause property damage; or where condensate or vapor could cause damage or could be detrimental to the operation of regulators, relief valves, or other equipment.

⚠ WARNING

ALWAYS turn on the boiler and test for gas leaks along the exhaust vent using a bubble test kit.

If the connections leak, carbon monoxide in the flue gas may cause serious injury or death.

5.2 About the Vent Installation Detector

This boiler unit comes pre-installed with a Vent Installation Detector ("VID") to assist the installer in properly installing the Vent Pipe into the vent collar.

How It Works

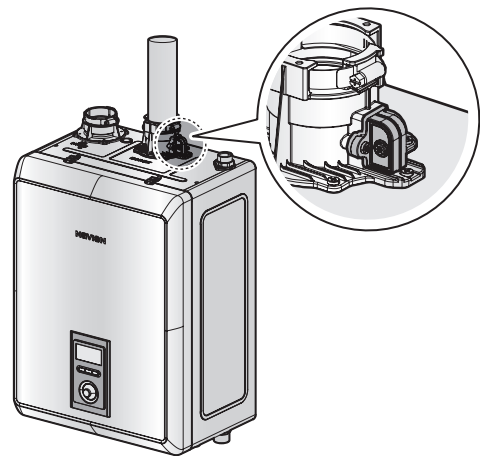

As shown, the VID is a device connected to the vent collar which is intended to detect whether the vent pipe has been inserted to a sufficient depth into the collar during its initial installation.

During installation, the VID detects whether the vent pipe is fully inserted (at least 2-3/4" (70 mm) into the collar. If a correctly sized vent pipe (2.0 inches) is fully inserted into the collar, it will press against a switch to activate the VID. If the vent pipe is not fully inserted into the collar, the unit will display an error message and will not operate. Make sure the vent pipe is correctly sized and has been inserted properly if Error 762 appears.

Purpose

The VID's purpose is to guide the installer to fully insert the vent pipe to a depth of at least 2- $\frac{3}{4}$ " (70 mm), into the collar. If the vent pipe is not properly inserted and installed, it could separate from the collar resulting in flue gas spillage and carbon monoxide emissions which will result in severe personal injury or death.

⚠ WARNING

Periodically inspect all vent pipe connections.

The Vent Installation Detector (VID) will NOT detect the separation of connected vent pipe if the joints become detached or are leaking flue gas that may contain carbon monoxide.

The VID is not intended and should not be relied upon to detect all instances of vent pipe movement or separation from the collar.

Various factors, including but not limited to sensor failure, switch sticking and corrosion, may cause the VID to not properly function if the vent pipe separates from the collar.

Limitations

The VID is not an alarm, safety switch or a substitute for a carbon monoxide detector. The VID may not cause the unit to stop operating if the vent pipe is partially or completely dislodged. Other factors can impact the performance of the VID causing it to be unable to function as intended. Such factors include, but are not limited to, deformity of the vent pipe, not using a correctly sized vent pipe, misalignment of the vent pipe into the collar, vertical movement of the vent pipe caused by improper installation, and other misuse or non-conformance with installation instructions.

⚠ WARNING

Carbon Monoxide Hazard

To prevent serious injury or death:

- ALWAYS insert vent pipe 2- $\frac{3}{4}$ " (70 mm) into the boiler exhaust collar.
- If the vent pipe is not fully inserted, the vent installation detector switch may not detect its presence and the boiler may not operate.
- ALWAYS only use the correctly sized vent pipe materials or an error code E762 can appear on the front panel if the vent pipe is not properly installed.
- The factors that can effect the performance of the VID include, but are not limited to, deformity of the vent pipe, not using a correctly sized vent pipe, misalignment of the vent pipe into the collar, vertical movement of the vent pipe caused by improper installation, and other misuse or non-conformance with installation instructions.
- ALWAYS visually inspect the vent pipe before inserting the vent pipe into the boiler collar. The vent pipe inserted into the boiler exhaust collar must be free from damage or defects for the vent installation detector to operate properly. If the vent pipe is damaged, then replace it with new vent pipe.
- The vent installation detector only detects separation of the vent pipe from the boiler exhaust collar if fully inserted 2- $\frac{3}{4}$ " (70 mm). The vent installation detector will not detect the separation of connected vent pipe if the joints become detached or are leaking flue gas that may contain carbon monoxide.
- It is the installer's responsibility to install the vent pipe properly, to check for leaks, and to adequately secure the boiler to the wall.

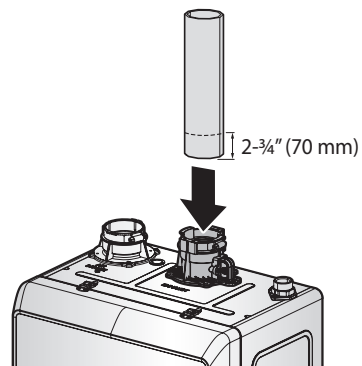

⚠ WARNING

Periodically inspect all vent pipe connections. The VID is not intended and should not be relied upon to detect all instances of vent pipe movement or separation from the collar.

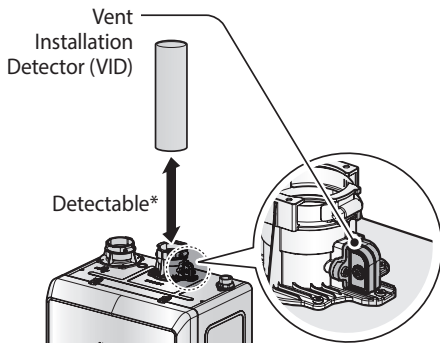

*If inserted 2-3/4" (70 mm), then VID should detect vent pipe.

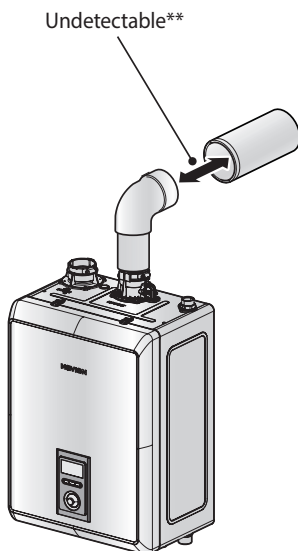

**VID can not detect if the vent pipe is leaking or disconnected at any point between the boiler and the exterior vent location or if the vent is blocked for any reason.

5.3 Selecting a Vent Type

All Navien boilers are Category IV appliances and prepared at the factory to be direct vented (sealed combustion). Navien recommends direct air vent installations whenever possible to avoid back drafting cold air through the boiler unit. If you cannot use a direct vent, ensure that an ample supply of make-up air is available in the installation location.

Navien also recommends installing a new vent system with this appliance. If reusing an existing vent system, thoroughly inspect it for punctures, cracks, or blockages prior to connecting it to the boiler.

Direct Venting

The boiler uses a 2 in or 3 in diameter exhaust and a 2 in or 3 in diameter air intake ducts. To ensure the draw of air directly from and exhaust of air directly to the outside of the building, create an airtight seal from the boiler collar to the vent termination.

Intake materials can be made of ABS, PVC, CPVC, PP, galvanized or stainless steel, corrugated aluminum or any other such materials. If you use a corrugated material, ensure that there is not inadvertent crimping of, or damage to, the intake air pipe.

When using direct venting, maintain the following venting clearances, as required by **ANSI Z21.10.3 and the National Fuel Gas Code, ANSI Z223.1/ NFPA 54, and CAN/CGA B149.1 Natural Gas and Propane Installation Code:**

Terminal Clearances for Direct Vent Installations

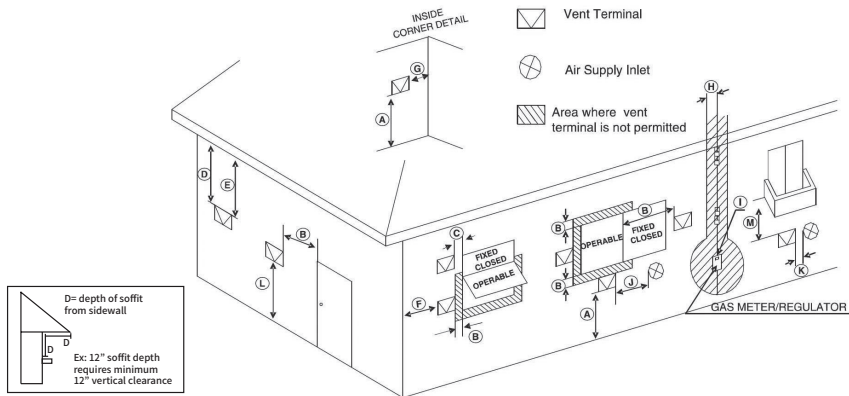

Ref	Description	Canadian Direct Vent Installations ¹	US Direct Vent Installations ²
A	Clearance above grade, veranda, porch, deck, or balcony	12 in (30 cm)	12 in (30 cm)
B	Clearance to window or door that may be opened	36 in (91 cm)	12 in (30 cm)
C	Clearance to permanently closed window	0 in (0 cm) ⁵	0 in (0 cm) ⁵
D	Vertical clearance to ventilated soffit located above the terminal within a horizontal distance of 2 ft (61 cm) from the center line of the terminal	Equal or greater than soffit depth ^{4, 5}	Equal or greater than soffit depth ^{4, 5}
E	Clearance to unventilated soffit	Equal or greater than soffit depth ^{4, 5}	Equal or greater than soffit depth ^{4, 5}
F	Clearance to outside corner	2 ft (61 cm)*	2 ft (61 cm)*
G	Clearance to inside corner	12 in (30 cm)*	12 in (30 cm)*
H	Clearance to each side of center line extended above meter/regulator assembly	3 ft (91 cm) within a height 15 ft above the meter/regulator assembly	3 ft (91 cm) within a height of 15 ft (4.6 m)*
I	Clearance to service regulator vent outlet	3 ft (91 cm)	3 ft (91 cm)*
J	Clearance to nonmechanical air supply inlet to building or the combustion air inlet to any other appliance	36 in (91 cm)	12 in (30 cm)
K	Clearance to a mechanical air supply inlet	6 ft (1.83 m)	3 ft (91 cm) above if within 10 ft (3 m) horizontally
L	Clearance above paved sidewalk or paved driveway located on public property	7 ft (2.13 m) [†]	7 ft (2.13 m) [†]
M	Clearance under veranda, porch deck, or balcony	12 in (30 cm) [‡]	12 in (30 cm) - open on 3 sides*

*Suggested clearances by the manufacturer. If the clearances required by local codes are different from those from the table above, the greater clearance should apply.

1 In accordance with the current CSA B149.1 Natural Gas and Propane Installation Code

2 In accordance with the current ANSI Z223.1/NFPA 54 National Fuel Gas Code

3 If locally adopted installation codes specify clearances different than those illustrated, then the most stringent clearance shall prevail.

4 Soffit with 12" depth requires a minimum of 12" vertical clearance from the termination (36" soffit requires a minimum of 36" vertical clearance)

5 In the areas where corrosion and discoloration of building materials can occur, a minimum clearance of 12" shall apply.

† A vent shall not terminate directly above a sidewalk or paved driveway that is located between two single family dwellings and serves both dwellings.

‡ Permitted only if veranda, porch, deck, or balcony is fully open on a minimum of two sides beneath the floor.

Direct exhaust vapors and condensate away from building materials to avoid degradation. The minimum distance from adjacent public walkways, adjacent buildings, openable windows, and building openings shall not be less than those values specified in the National Fuel Gas Code, ANSI Z223.1/NFPA 54, and/or the Natural Gas and Propane Installation Code, CSA B149.1.

Non-Direct Venting (Single Pipe)

If, at any time, the installation location could experience negative pressure, there is a possibility of back drafting cold air through the boiler's heat exchanger. This situation could lead to the freezing of the heat exchanger and malfunction of the boiler.

However, building codes in most jurisdictions disallow negative pressures in residences. In a home with a well-balanced air supply, the heat exchanger should not be in danger of freezing. Because the cause of back drafting is not considered a manufacturing problem, any freezing damage which occurs from back drafting will not be covered by the Navien warranty. If there is any question about the possibility of back drafting in the installation location, use a direct venting system for the boiler.

When using non-direct venting, maintain non-direct vent clearances shown on page 60 as required by **ANSI Z21.10.3 and the National Fuel Gas Code, ANSI Z223.1/NFPA 54, and CAN/CSA B149.1 Natural Gas And Propane Installation Code.**

To use non-direct venting for the boiler:

1. Insert the termination end cap into the intake air duct. Do not glue the end cap, to allow for easy removal and cleaning of the cap.

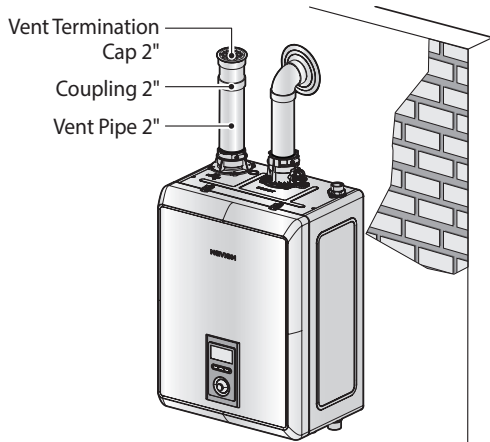

2. Provide two openings to allow for circulation of combustion air as specified by ANSI Z223.1/NFPA 54 or CAN/CGA B-149.1:

	NHB-055H	NHB-080H	NHB-110H	NHB-150H
Maximum Input (BTU/H)	55,000	80,000	110,000	150,000
Outdoor make up air is provided, a minimum free area of 1 in ² , per 4,000 BTU/H	14 in ² 6 in (W) x 3 in (H) or 5 in round	20 in ² 7 in (W) x 3 in (H) or 5 in round	28 in ² 10 in (W) x 3 in (H) or 6 in round	40 in ² 10 in (W) x 4 in (H) or 7 in round
Indoor make up air is provided, a minimum free area of 1 in ² per 1,000 BTU/H	55 in ² 7 1/2 in (W) x 7 1/2 in (H)	80 in ² 9 in (W) x 9 in (H)	110 in ² 10 1/2 in (W) x 10 1/2 in (H)	150 in ² 12 1/4 in (W) x 12 1/4 in (H)

Terminal Clearances for Non-Direct Vent Installations

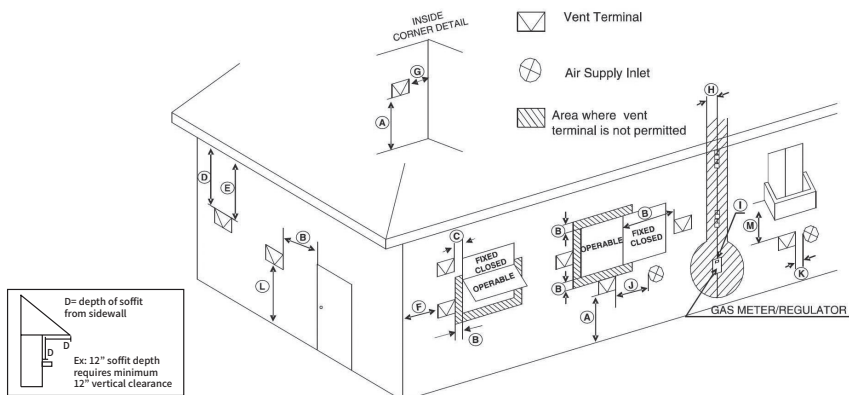

Ref	Description	Canadian Non-Direct Vent Installations ¹	US Non-Direct Vent Installations ²
A	Clearance above grade, veranda, porch, deck, or balcony	12 in (30 cm)	12 in (30 cm)
B	Clearance to window or door that may be opened	36 in (91 cm)	48 in (120 cm) below or to side of opening; 12 in (30 cm) above opening
C	Clearance to permanently closed window	0 in (0 cm) ⁵	0 in (0 cm) ⁵
D	Vertical clearance to ventilated soffit located above the terminal within a horizontal distance of 2 feet (61 cm) from the center line of the terminal	Equal or greater than soffit depth ^{4,5}	Equal or greater than soffit depth ^{4,5}
E	Clearance to unventilated soffit	Equal or greater than soffit depth ^{4,5}	Equal or greater than soffit depth ^{4,5}
F	Clearance to outside corner	2 ft (61 cm)*	2 ft (61 cm)*
G	Clearance to inside corner	12 in (30 cm)*	12 in (30 cm)*
H	Clearance to each side of center line extended above meter/regulator assembly	36 in (91 cm) within a height 15 ft (4.57 m) above the meter/regulator assembly	3 ft (91 cm) within a height of 15 ft (4.6 m)*
I	Clearance to service regulator vent outlet	36 in (91 cm)	3 ft (91 cm)*
J	Clearance to non-mechanical air supply inlet to building or the combustion air inlet to any other appliance	36 in (91 cm)	48 in (120 cm) below or to side of opening; 12 in (30 cm) above opening
K	Clearance to a mechanical air supply inlet	6 ft (1.83 m)	36 in (91 cm) above if within 10 ft (3 m) horizontally
L	Clearance above paved sidewalk or paved driveway located on public property	7 ft (2.13 m) [†]	7 ft (2.13 m) [†]
M	Clearance under veranda, porch deck, or balcony	12 in (30 cm) [‡]	12 in (30 cm) - open on 3 sides*

*Suggested clearances by the manufacturer. If the clearances required by local codes are different from those from the table above, the greater clearance should apply.

1 In accordance with the current CSA B149.1 Natural Gas and Propane Installation Code

2 In accordance with the current ANSI Z223.1/NFPA 54 National Fuel Gas Code

3 If locally adopted installation codes specify clearances different than those illustrated, then the most stringent clearance shall prevail.

4 Soffit with 12" depth requires a minimum of 12" vertical clearance from the termination (36" soffit requires a minimum of 36" vertical clearance)

5 In the areas where corrosion and discoloration of building materials can occur, a minimum clearance of 12" shall apply.

† A vent shall not terminate directly above a sidewalk or paved driveway that is located between two single family dwellings and serves both dwellings.

‡ Permitted only if veranda, porch, deck, or balcony is fully open on a minimum of two sides beneath the floor.

Direct exhaust vapors and condensate away from building materials to avoid degradation. The minimum distance from adjacent public walkways, adjacent buildings, openable windows, and building openings shall not be less than those values specified in the National Fuel Gas Code, ANSI Z223.1/NFPA 54, and/or the Natural Gas and Propane Installation Code, CSA B149.1.

5.4 Selecting Vent Pipe Materials

Venting requirements differ in the US and Canada. Consult the following chart or the most recent edition of ANSI Z223.1/NFPA 54 or CAN/CGA B149.1, as well as all applicable local codes and regulations when selecting vent pipe materials. Do not use cellular core PVC (ASTM F891), cellular core CPVC, or Radel® (polyphenolsulfone) for the exhaust vent.

⚠ WARNING

Carbon Monoxide Hazard

To prevent serious injury or death:

- ONLY use approved venting materials.
- NEVER mix different types of vent pipe materials. The vent system may fail and harmful flue products may leak into the living space. The use of more than one type of pipe for the vent piping will also void the warranty and certification of the boiler.

Locale	Recommended Vent Materials
USA	<ul style="list-style-type: none"> • PVC/CPVC Schedule 40 or 80 (Solid Core) • UL1738 approved PVC or CPVC • Approved Polypropylene (PP) • Approved Stainless Steel (SS)
Canada*	<ul style="list-style-type: none"> • Type BH Special Gas Vent Class IIA (PVC) • Type BH Special Gas Vent Class IIB (CPVC) • Type BH Special Gas Vent Class IIC (Polypropylene/Stainless Steel)

* For installation in Canada, field-supplied plastic vent piping must comply with CAN/CGA B149.1 (latest edition) and be certified to the Standard For Type BH Gas Venting Systems, ULC-S636. Components of this listed system must not be interchanged with other vent systems or unlisted pipes or fittings. All plastic components and specified primers and glues of the certified vent system must be from a single system manufacturer and must not be intermixed with another system manufacturer's parts. The supplied vent connector and vent termination are certified as part of the boiler.

The vent system shall be installed in accordance with the boiler manufacturer and, if applicable, the venting system manufacturer's instructions.

This product is set to use **PVC** as the default vent pipe material. If you require that return water hotter than 140°F (60°C) to circulate back to boiler, the DIP switch must be configured (**DIP SW2 (Set of 8 Switches) #8 to ON position**). Otherwise, the boiler will control and maintain the flue and DHW temperature below 150°F (65°C) and 140°F (60°C) respectively.

Note

When you set PCB DIP SW2 (Set of 8 Switches) #8 to On, ensure that CPVC, polypropylene or stainless steel piping is used for exhaust venting.

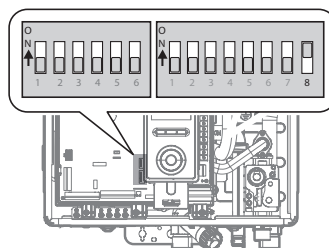

⚠ CAUTION

- This boiler has a built-in control to limit the exhaust temperature to 149°F (65°C). As a result, the boiler can be vented with Schedule 40 PVC.
- In high temperature applications, the exhaust temperature can exceed 149°F (65°C). In that case, you must use Schedule 40/80 CPVC or Approved Polypropylene/Stainless Steel in the USA or Type BH Special Gas Vent Class IIB (CPVC) or Class IIC (Polypropylene/SS) that conforms to ULC-S636 in Canada.
- When using 2 in. vent, if the exhaust temperature exceeds 149°F (65°C), CPVC pipe (field supplied) must be used for the first 3 feet of equivalent pipe length. For systems using 3 in. vent, the first 5 in. of length must be CPVC pipe.

The following **polypropylene** vent components are approved for use with this appliance:

Duravent PolyPro® SW (Rigid) (Certified to ULCS636)
2PPS-xxx (2") or 3PPS-xxx (3")

Centrotherm Innoflue® SW (Rigid) (Certified to UL1738 and ULCS636)

ISxx02xx (2") or ISxx03xx (3")

Duravent PolyPro® (Flexible) (Certified to ULCS636)
3PPS -FLEXxx (3")

2PPS-FAM or 3PPS-FAM (2" or 3" Rigid-to-Flex Male Adapter)

2PPS-X3L (2" to 3" Increaser)

Centrotherm Innoflue® (Flexible) (Certified to UL1738 and ULCS636)

IFVL02xxx (2") or IFVL03x xx (3")

IFSFC02 or IFSFC03 (2" or 3" Rigid-to-Flex Male Adapter)

ISEI0203 or ISIA0203 (2" to 3" Increaser)

Hart & Cooley Polyflue™ SW (Rigid) (Certified to ULCS636)

2PF-xx (2") or 3PF-xx (3")

Z-Flex Z-DENS SW (Rigid) (Certified to UL1738 and ULCS636)

2ZDP ___ (2" or 3")

The following **stainless steel** vent components are approved for use with this appliance:

Duravent FasNSeal® (Rigid) (Certified to UL1738 and ULCS636)

FSA-PVC3 (3" PVC to FasN Seal Appliance Adapter)

FSxxxx03 (3")

Duravent FasNSeal® (Flexible) (Certified to UL1738 and ULCS636)

FSASMM-PP-2 (2" PP-to-F asNSeal adapter)

FSFLEX-02 (2")

Heat Fab Saf-T Vent® EZ Seal (Certified to UL1738 and ULCS636)

9301PVC (3" PVC/CPVC Outlet Boiler Adapter)

93xx (3")

Z-Flex Z Vent (Certified to UL1738 and ULCS636)

2SVSTTA023 (2" x 3" Appliance Adapter)

2SVEPSCF030X (Straight Pipe)

2SVEEWCF0390 (90° Elbow)

2SVEEWCF0345 (45° Elbow)

ECCO Polypropylene Vent (Rigid) (Certified to ULCS 636)

2xxPPP (2") or 3xxPPP (3")

245PEL/287PEL (2" 45°/90° Elbow)

345PEL/387PEL (3" 45°/90° Elbow)

203PINC (2" x 3" Increaser)

Note

- Only the vent pipe models listed above are approved for use with this appliance.
- Refer to the vent manufacturer's instructions for detailed installation procedures and guidelines.
- Do not use Schedule 40 or 80 polypropylene pipe used for water or waste systems within the vent run.

5.5 Measuring Vent Length

The maximum vent length when using 2 in exhaust ducts is 65 ft (19.5 m). The maximum vent length when using 3 in vent ducts is 150 ft (45 m). The intake and exhaust vent pipes can be of different lengths as the boiler will adjust for pressure imbalances within the system. Maximum vent lengths are reduced according to the number of elbows used, as shown in the following table:

Vent Size	Maximum Length	Maximum # of 90° Elbows	Equivalent Length
2 in	65 ft (19.5 m)	6	Reduce the maximum vent length accordingly for each elbow used: <ul style="list-style-type: none"> • Each 90° elbow equates to 8 linear feet of vent • Each 45° elbow equates to 4 linear feet of vent
3 in	150 ft (45 m)	8	Reduce the maximum vent length accordingly for each elbow used: <ul style="list-style-type: none"> • Each 90° elbow equates to 5 linear feet of vent • Each 45° elbow equates to 3 linear feet of vent

Note

- The Maximum Length does not include any elbows.
- The use of a PVC or polypropylene termination kit counts as 5 linear feet (1.5 m) of vent.
- The use of a tee counts for the same equivalent length as a 90° elbow for the vent size.
- The maximum vent lengths at high altitudes are the same as shown in the table above.

5.6 Terminating the Vent

Before installing the boiler, determine what type of vent termination is appropriate for the installation location and materials. The subsections that follow describe some typical venting configurations, but do not include all possible options.

The following **PVC** vent terminations are approved for use with this appliance:

- **PVC Concentric Vent Kit** (Sch 40 - UL1738/ULC S636):
 - 2 in Vent Kit
 - 3 in Vent Kit
- **IPEX Low Profile Termination Kit** (Certified to ULCS636)
 - 2 in Low Profile Vent Kit #196984
 - 3 in Low Profile Vent Kit #196985
- **IPEX Low Profile Termination Kit** (Certified to UL1738)
 - 2 in Low Profile Vent Kit #397984
 - 3 in Low Profile Vent Kit #397985
- **IPEX Universal Vent Kit**
- **Diversitech**
 - 2 in Concentric Vent Kit #CVENT2
 - 3 in Concentric Vent Kit #CVENT3
 - 2 in Low Profile Vent Kit #HVENT2
 - 3 in Low Profile Vent Kit #HVENT3

The following **polypropylene** vent terminations are approved for use:

- **Duravent PolyPro** Horizontal Concentric Termination Kit (Certified to ULCS636)
 - 2 in x 4 in Concentric Vent Kit #2PPS-HKC
 - 3 in x 5 in Concentric Vent Kit #3PPS-HKC
- **Centrotherm Innoflue** Low Profile Termination Kit (Certified to UL1738 and ULCS636)
 - 2 in Vent Kit #ISLPT0202
 - 3 in Vent Kit #ISLPT0303
- **Centrotherm Innoflue** Concentric Vent Kit (Certified to UL1738 and ULCS636)
 - 2 in Vent Kit #ICWT242
 - 3 in Vent Kit #ICWT352
- **Hart & Cooley Polyflue** Horizontal Termination Kit (Certified to ULCS636)
 - 2 in Vent Kit #2PF-HCT
 - 3 in Vent Kit #3PF-HCT
- **Z-Flex Z DENS** Horizontal Termination Kit (Certified to UL1738 and ULCS636)
 - 2 in Vent Kit #2ZDHK2
 - 3 in Vent Kit #2ZDHK3
- **IPEX Universal Concentric Vent Kit** (Certified to ULCS636)
 - 2 or 3 in. PVC #196256
 - 2 or 3 in. CPVC #197256 (Certified to UL1738)
 - 2 or 3 in. PVC #397256
- **Royal Pipe** Low Profile Concentric Vent Kit (Certified to ULCS636)
 - 2 in. PVC #52CVKGV6502
 - 3 in. PVC #52CVKGV6503
 - 3 in. CPVC #52CVKGVSF9003

The following **polypropylene** vent components are approved for use as terminations:

Duravent PolyPro® (Certified to ULCS636)
2PPS-E90L or 3PPS-E90L (2" or 3" 90° Elbow)
2PPS-E45L or 3PPS-E45L (2" or 3" 45° Elbow)
2PPS-TL or 3PPS-TL (2" or 3" Tee)
2PPS-BG or 3PPS-BG (2" or 3" Birdscreen)

Centrotherm Innoflue® (Certified to UL1738 and ULCS636)
ISELL0287 or ISELL0387 (2" or 3" 87° Elbow)
ISELL0245 or ISELL0345 (2" or 3" 45° Elbow)
IST02 or IST03 (2" or 3" Tee)
IASPP02 or IASPP03 (2" or 3" Birdscreen)

Hart & Cooley Polyflue™ (Certified to ULCS636)
2PF-90 or 3PF-90 (2" or 3" 90° Elbow)
2PF-45 or 3PF-45 (2" or 3" 45° Elbow)
2PF-T or 3PF-T (2" or 3" Tee)
2PF-HVST or 3PF-HVST (2" or 3" Birdscreen)

The following **stainless steel** (AL29-4C) vent components are approved for use as terminations:

Duravent FasNSeal® (Certified to UL1738 and ULCS636)
FSELB9003 (3" 90° Elbow)
FSELB8803 (3" 88° Elbow)
FSELB4503 (3" 45° Elbow)
FST3 (3" Tee)
FSBS3 (3" Birdscreen)

Heat Fab Saf-T Vent® **EZ Seal** (Certified to UL1738 and ULCS636)
9314(LR) or 9314TERM (3" 90° Elbow)
9311 (3" 45° Elbow)
9390TEE (3" Tee)
9392 (3" Birdscreen)

Z-Flex Z Vent (Certified to UL1738 and ULCS636)
2SVEEWCFO390 (90° Elbow)
2SVEEWCFO345 (45° Elbow)
2SVSTTF03 (3" Tee)

ECCO Polypropylene Vent (Rigid) (Certified to ULCS636)
2 in. Vent Kit #24022AD
3 in. Vent Kit #35033AD

Note

- Only the termination models listed above are approved for use with this appliance.
- Only terminations of the same manufacturer as the vent system must be used.
- Refer to the vent manufacturer's instructions for detailed installation procedures and guidelines.

Indoor Boiler Installation Venting

Examples

⚠ WARNING

Fire and Explosion Hazard

To prevent death, serious injury or property damage:

- ALWAYS make sure to follow the provided clearance requirements.
- Failure to do so may result in circulating exhaust gas and cause dangerous operation of the boiler.

The following are some possible indoor venting options:

- Two-Pipe Sidewall Venting

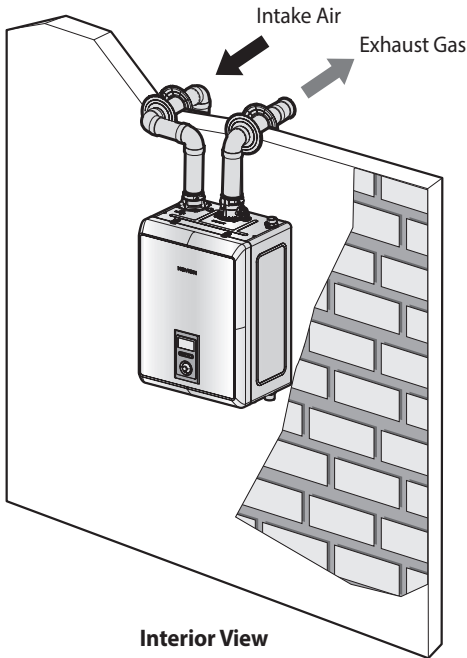

Interior View

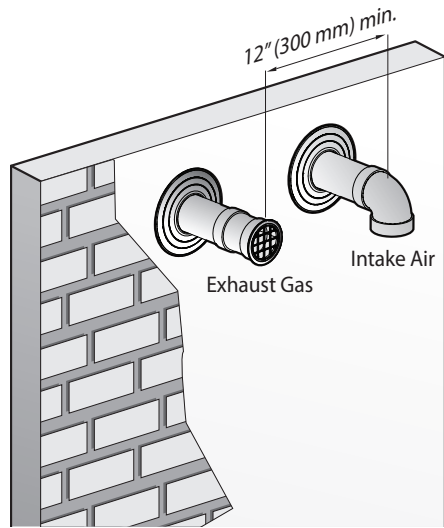

Exterior View

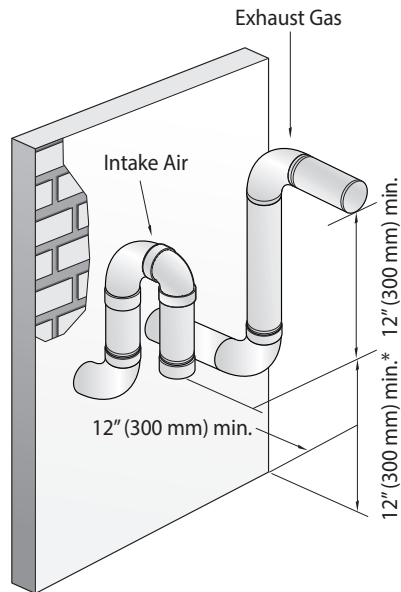

Two-Pipe Snorkel Sidewall Venting

* Clearance above highest anticipated snow level or grade, or as required by local codes, whichever is greater.

- Two-pipe Vertical Venting - Intake and exhaust pipes do not have to terminate in the same area.

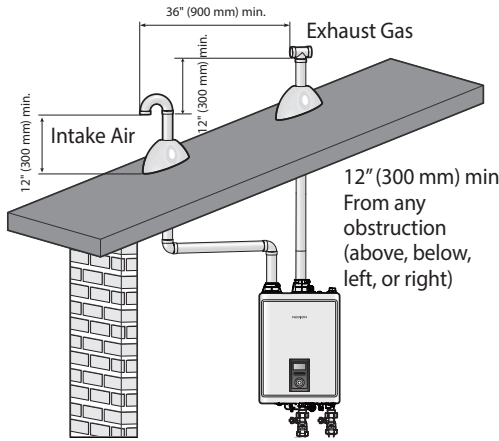

- Non-Concentric Sidewall Venting - Air is drawn from a different location that is at least 12 in (300 mm) away from the exhaust termination. The exhaust termination can be located either on the sidewall or roof. Try to minimize the length of the intake air pipe when installing the vent.

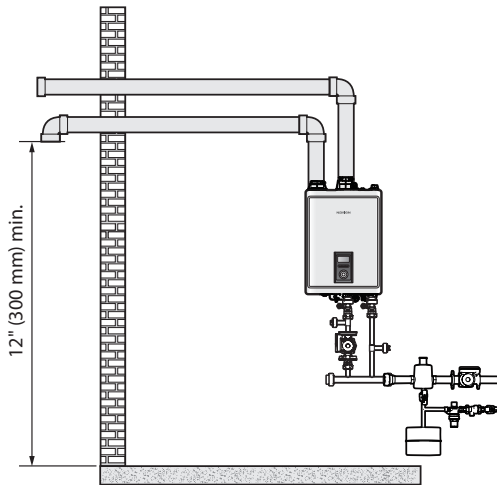

* 12" (300 mm) above the highest anticipated snow level, or as required by local codes, whichever is greater

- Concentric Sidewall Venting

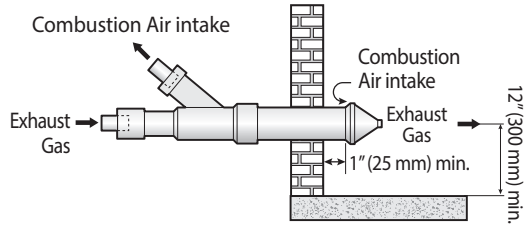

Maintain 12" (300 mm) min. clearance above highest anticipated snow level or grade, whichever is greater.

- Concentric Vertical Venting

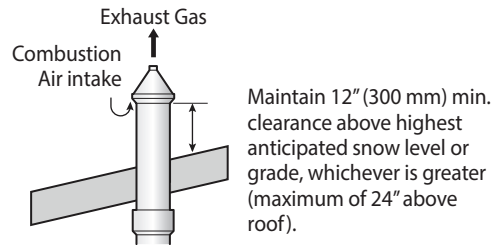

Note For cascade applications, the required horizontal clearance between terminations is 12" for both sidewall and vertical venting installations.

CAUTION



Do not vertically stack concentric terminations on sidewalls. The circulation of exhaust gases will cause improper operation of the boiler.

- Multiple Low-Profile Terminations on Sidewall (Cascade Only)

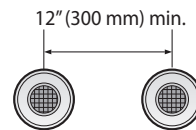

- Multiple Low-Profile Terminations on Roof (Cascade Only)

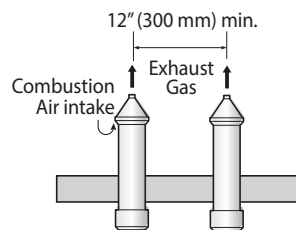

Indoor Boiler Installation Venting Examples (continued)

- Low Profile Two-Pipe Sidewall Venting*

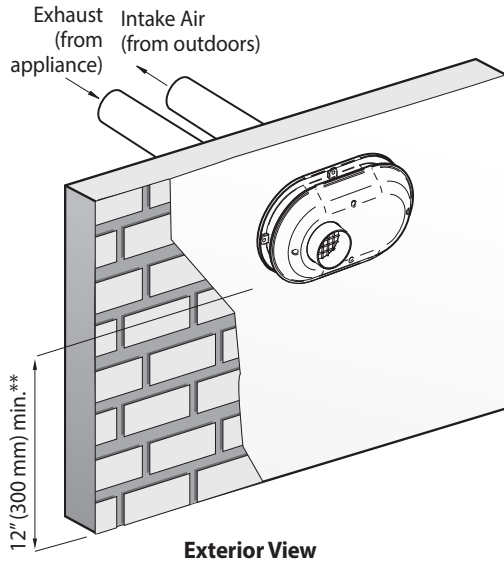

* IPEX and Centrotherm Low Profile terminations only

** Clearance above highest anticipated snow level or grade, or as required by local codes, whichever is greater

Note Only the following orientations are allowed for twin pipe terminations.

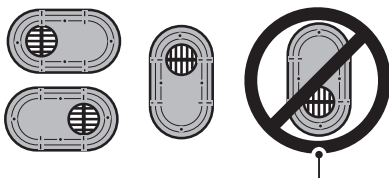

NEVER install in this orientation with the exhaust located nearest to the ground.

- Flexible Vent Systems (Polypropylene)

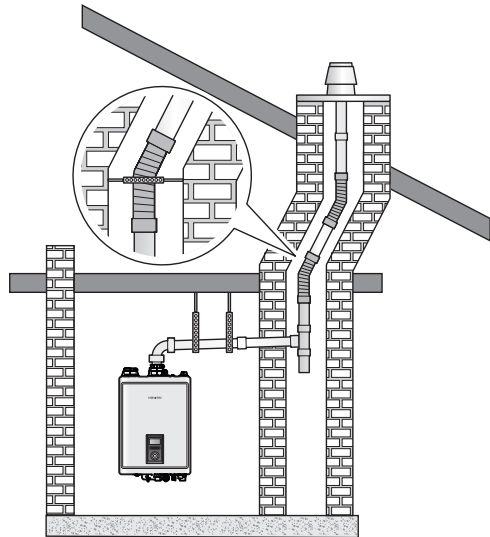

- Note**
- Only VERTICAL installations are allowed. Horizontal terminations are prohibited.
 - The use of proper adapters and supports are required to fully complete the installation.

The following table lists the flexible vent models that are approved for use with this appliance in addition to the maximum allowable vent lengths for the desired vent system.

Vent Dia.	Flexible PP
	Centrotherm InnoFlue Flex
2 in	50 ft

- Only the flexible vent models listed above are approved for use with this appliance.
- All flexible vent pipe must be installed VERTICALLY through the roof. No horizontal terminations are permitted.
- Use a 2 in snap fit coupler or the InnoFlue® Single Wall Residential vent pipes to connect the InnoFlue® Flex 2 in vent pipes to the exhaust.
- After installation, ensure that the vent system is tightly sealed at the joints.
- All installations using the flexible vent materials must be in INDIRECT VENTING only.
- Refer to the vent manufacturer's literature for detailed information and guidelines.

6. Setting the DIP Switches

⚠ WARNING

- **Do not remove the front cover unless the power to the boiler is turned off or disconnected.** Failure to do so may result in electric shock.
- Configure only the DIP switches that require adjustment according to the instructions in this manual. Do not adjust any other DIP switches.
- Ensure that the High Altitude setting reflects the actual location of the boiler. If not, it may cause personal injury or malfunction of the boiler.

The boiler has 2 sets of DIP switches on the main circuit board (PCB). DIP switches are used to control the functionality of the boiler. Set the DIP switches appropriately, based on the installation environment.

6.1 DIP Switch 1 (Set of 6 Switches)

The DIP SW1 (Set of 6 Switches) on the circuit board configures the operation status and model settings.

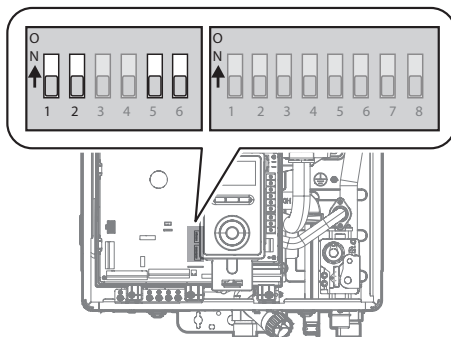

Switch	Function	Setting	
1 & 2	Operation Status	Normal Operation	1-OFF, 2-OFF
		2-stage MAX	1-ON, 2-OFF
		1-stage MIN	1-OFF, 2-ON
		1-stage MAX	1-ON, 2-ON
5 & 6	Model Setting	NHB-055H	5-OFF, 6-OFF
		NHB-080H	5-ON, 6-OFF
		NHB-110H	5-OFF, 6-ON
		NHB-150H	5-ON, 6-ON

6.2 Dip Switch 2 (Set of 8 Switches)

The DIP SW2 (Set of 8 Switches) on the circuit board configures the gas type, altitude, temperature control modes, country, and enables or disables the space heating thermostat.

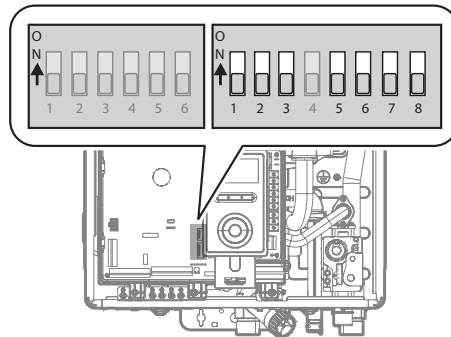

Switch	Function	Setting		Comment	
1	Gas Type	Natural Gas	1-OFF	Refer to Table 1 in "12.1 Gas & High Altitude Conversion" on page 120.	
		Propane Gas	1-ON		
2 & 3	High Altitude*	0-1,999 ft (0-609 m)	2-OFF, 3-OFF		
		2,000-5,399 ft (610-1,645 m)	2-ON, 3-OFF		
		5,400-7,699 ft (1,646-2,346 m)	2-OFF, 3-ON		
		7,700-10,100 ft (2,347-3,078 m)	2-ON, 3-ON		
4	Input rate compensation	Used	4-OFF		-
		Unused	4-ON		-
5 & 6	Reserved	-	-	-	
7	Space Heating Thermostat	Used	7-OFF	-	
		Unused	7-ON	-	
8	Exhaust Temperature Control	Used	8-OFF	-	
		Unused	8-ON	-	

* Please confirm the installation elevation by using the provided QR code to access the following website (<https://www.navianc.com/elevation>) and entering the proper zip/postal code.



Note

- When PCB DIP switch 2 #8 is set to On, ensure that CPVC or polypropylene piping is used for exhaust venting.
- This unit may be installed at elevations up to 10,100 ft (3,078 m) for use with natural gas and propane. To use the unit at a specific altitude, the DIP switches should be set as described above.
- High Altitude: Above 2,000 ft (610 m), the unit will de-rate by 3% for each 1,000 ft (305 m) of altitude gain for NG and 4% de-rate for propane gas.
- For NG, if you install the unit at above 5,400 ft (1,646 m), it is required to change the Gas Orifice for high altitude. Be careful not to confuse it with the Gas Orifice for LP. Refer to "12.1 Gas & High Altitude Conversion" on page 120 for details.
- Common vent installations for use with natural gas and propane are only approved for up to 4,500 ft.

 WARNING

- ALWAYS install the High Altitude Conversion Kit if needed based on the elevation of the installation location.
- For use with Propane (LP) gas, the Propane Gas & High Altitude Conversion Kit **MUST** be used for elevations **up to 10,100 ft.**
- The Natural Gas High Altitude Conversion Kit is located inside the boiler cabinet. You will need to remove the front cover to access the Natural Gas High Altitude Conversion Kit.
- Refer to the Natural Gas High Altitude Conversion Guide and verify the orifice is appropriate for the boiler. Replace the orifice following the Natural Gas High Altitude Conversion Guide instructions if required.

7. Connecting the Power Supply

WARNING

Electric Shock Hazard

To prevent serious injury or death:

- ALWAYS follow all applicable electrical codes of the local authority having jurisdiction.
- In the absence of such requirements, follow the latest edition of the National Electrical Code (NFPA 70) in the USA or the latest edition of CSA C22.1 Canadian Electrical Code Part 1 in Canada.
- ONLY licensed professionals should connect the power supply.
- ALWAYS label all wires before disconnecting them when you work on the controls.
- Wiring errors can cause improper and dangerous operation.
- ALWAYS verify proper operation after servicing.

When connecting the power supply, follow these guidelines:

- Do not connect the electric supply until all plumbing and gas piping is complete and the boiler has been filled with water.
- The boiler must be connected to a dedicated 110-120V AC power supply with circuit breaker. Do NOT connect the boiler to a 220-240V AC power supply. Doing so will damage the boiler and void the warranty.
- All the Navien NHB-H boilers are supplied with a factory-installed 5 ft (1.5 m), 3-pronged (grounded) plug. The boiler's current rating is 12 A and can be plugged into any grounded electrical outlet adjacent to the boiler.

CAUTION

Ensure that the power supply to the boiler is disconnected to prevent injury due to electrical shock.

If local codes require the boiler to be wired directly, remove and discard the factory-installed plug. See below for recommended procedures:

- Cut the existing power cord about 2" below the bottom of the cabinet. Dispose the power cord.
- Open the front cover by unlocking the 4 provided latches to access the inside of the boiler.
- From inside the case, locate the BLACK (hot), WHITE (neutral), and GREEN (wires) that are connected to the disposed power cord. Cut these wires as close as possible to the end of the power cord where it is uninsulated.
- These wires can be directly spliced with an external power supply. Strip approximately 1/2" of sheathing from each wire to expose the bare wire.
- Connect 110-120V AC power directly to the exposed wiring using field supplied twist-on wire connectors (or wire nuts).

- The boiler must be electrically grounded. If using the power plug, ensure that the electrical outlet you connect the boiler to is properly grounded. If wiring the boiler directly to a power supply, do not attach the ground wire to gas or water pipes as plastic pipe or dielectric unions may prevent proper grounding.
- We recommend using a surge protector to protect the boiler from power surges.
- If there is a power failure in cold weather areas, the freeze prevention system in the boiler will not operate and may result in the heat exchanger freezing. In cold areas where power failures are common, you must completely drain the boiler to prevent damage if power cuts last for extended periods. A battery back-up (available at most computer retailers) may be used to supply hot water during power outages. Damage caused by freezing is not covered under warranty.

If you are not using your boiler for a long period of time:

1. Completely drain the water out of the boiler.
2. Disconnect the power supply to the boiler.

This prevents your boiler from freezing and being damaged.

 **WARNING**

Electric Shock Hazard

To prevent serious injury or death:

- ALWAYS label all wires before disconnecting them when you work on the controls.
- Wiring errors can cause improper and dangerous operation.
- ALWAYS verify proper operation after servicing.

8. Installing a Cascade System

When installing a cascade system, carefully consider the design of the system and the features of the installation location. Follow all local codes and regulations, as well as all guidelines for installing the boiler. The following sections describe additional considerations that are specific to installing cascade systems. Read them carefully before designing or installing the system.

8.1 Connecting Water Supplies

Several options are available for plumbing a cascade system of boilers. The options shown here are only examples. The setup you choose will vary based on the installation location, local building codes, and other factors. Follow all applicable regulations when installing a cascade system.

You can connect up to 16 boilers to meet high-volume heating demands. Some possible connection options include the following:

- Example of a Basic Cascade System Application

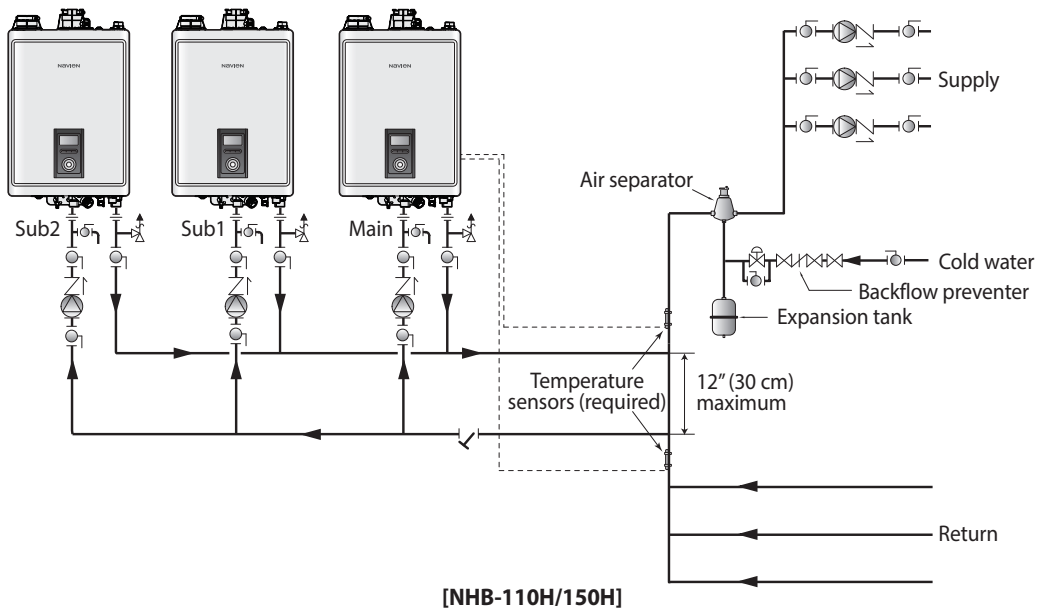

Note

- System application drawings are intended to explain the system piping concept only.
- Install a filter in the system return to remove foreign objects from the system. Foreign objects inside the system may result in abnormal system operation.
- Refer to “3.3 Filling the System” on page 26 for make-up water connections and refer to the requirements of your local codes to ensure compliance.
- Use pumps with integral check valves or install check valves at the pump outlets.
- Navien system supply (Included box)/return (Accessory) Temperature sensor must be installed for cascade system operation.
- Adjust the settings at the main unit as the cascade system uses only the main unit settings. Changes made to the sub units are ignored.
- Refer to “11.13.4 Configuring a Cascade System” on page 114 to make adjustments to the boiler staging settings. By default, boilers will be added to the system when the input capacity exceeds 70%, and removed when the input capacity falls below 30%.
- Connect zone pumps to the zone controller. Do not connect zone pumps to the main or sub units.

• System Application #1- Cascade System with Closely Spaced Tees

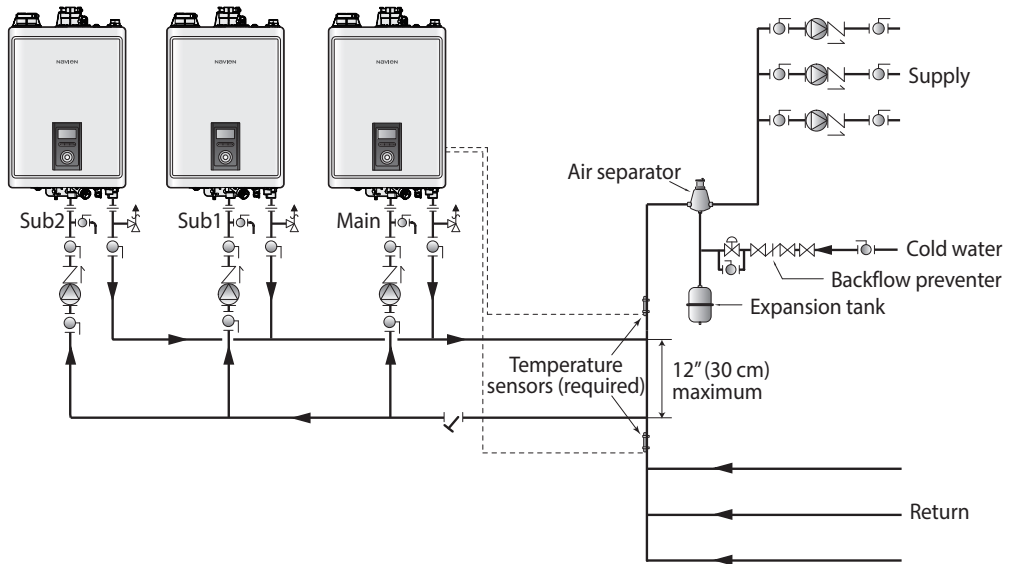

Note

- Connect the "SH Demand (SH T/T or Zone controller)" to the main unit.
- Connect the supply/return sensors to SUPPLY and RETURN terminals of the CNT1/2 terminal strip on the main unit PCB.
- Connect the outdoor sensor (optional) to the main unit.
- Install system pumps to the units (main and sub) as required by the system configuration. When configuring a cascade system, the output of the zone pumps installed at the main and sub units are used as the output of the secondary system pump.
- Connect zone pumps to the zone controller. Do not connect zone pumps to the main or sub units.

• System Application #2- Cascade System with Hydro Separator

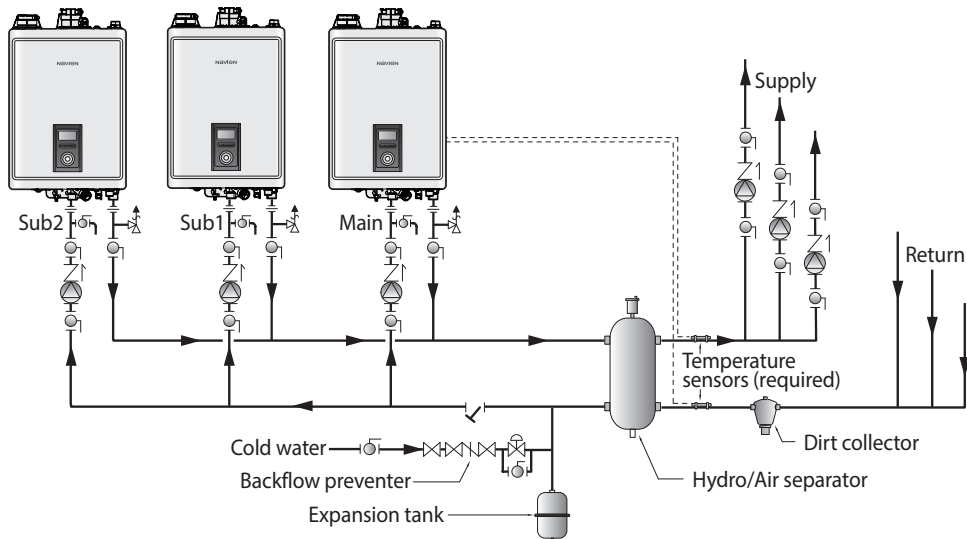

Note

- Connect the "SH Demand (SH T/T or Zone controller)" to the main unit.
- Connect the supply/return sensors to SUPPLY and RETURN terminals of the CNT1 terminal strip on the main unit PCB.
- Connect the outdoor sensor (optional) to the main unit.
- Install system pumps to the units (main and sub) as required by the system configuration.
- Connect zone pumps to the zone controller. Do not connect zone pumps to the main or sub units.

• System Application #3- Cascade System with DHW Indirect Tank (for High DHW Demand)

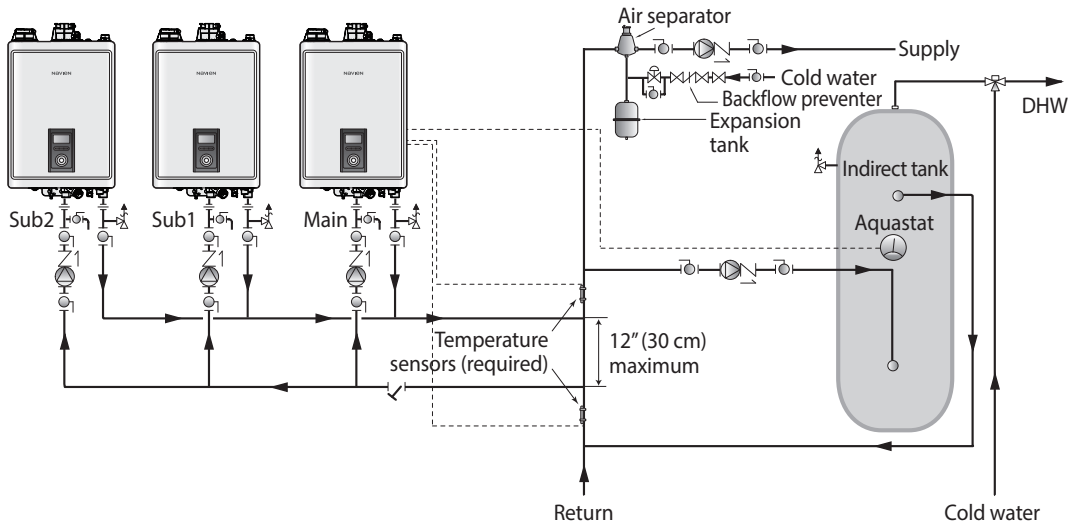

Note

- In this configuration, the full capacity of all boilers will be prioritized to the DHW demand.
- The aquastat on the DHW indirect tank must be connected to the main unit.
- Connect the DHW pump to the main unit.
- Connect the system pump to the units (main or sub).

• System Application #4- Cascade System with DHW Indirect Tank (for High DHW Demand)

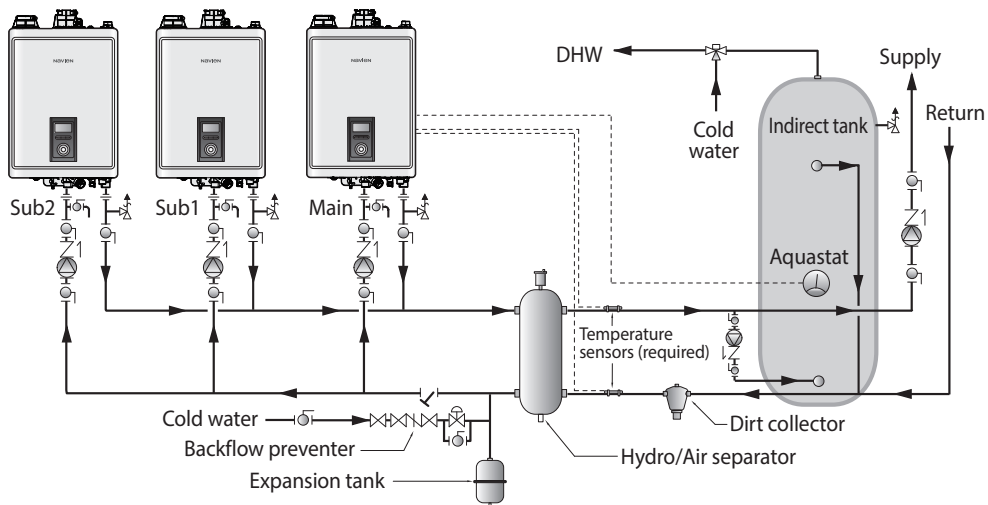

Note

- In this configuration, the full capacity of all boilers will be prioritized to the DHW demand.
- The aquastat on the DHW indirect tank must be connected to the main unit.
- Connect the DHW pump to the main unit.
- Connect the system pump to the units (main or sub).

- System Application #5- Cascade System with DHW Indirect Tank (for Low DHW Demand)

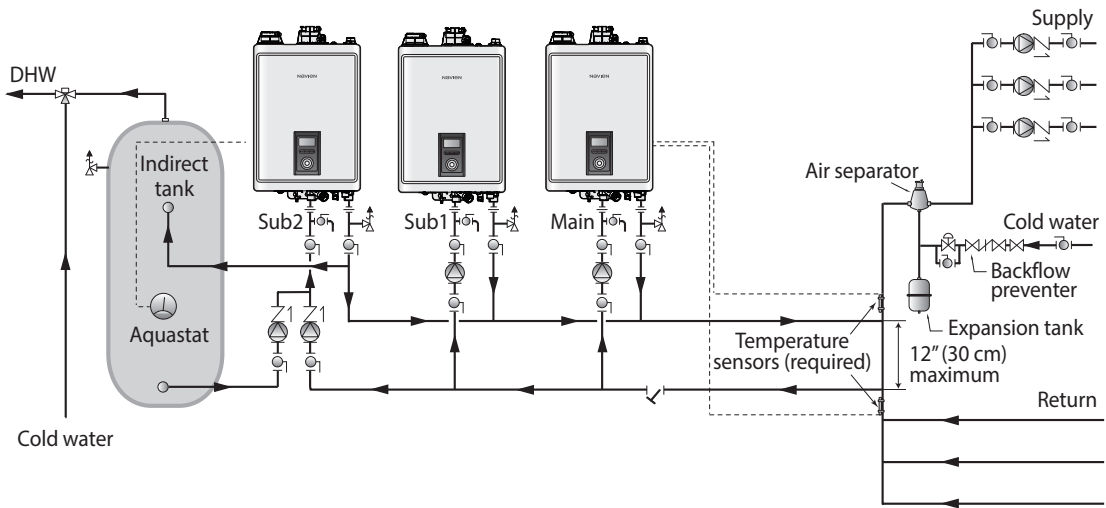

Note

- In this configuration, space heating and DHW can operate simultaneously.
- The aquastat on the DHW indirect tank must be connected to a sub unit.
- If a dedicated sub unit is used, the input capacity requirement of the indirect tank shall not exceed the capacity of the single boiler.
- Connect the DHW pump to the sub unit.
- Connect zone pumps to the zone controller. Do not connect zone pumps to the main or sub units.

- System Application 6 - Cascade System with DHW Indirect Tank (for Low DHW Demand)

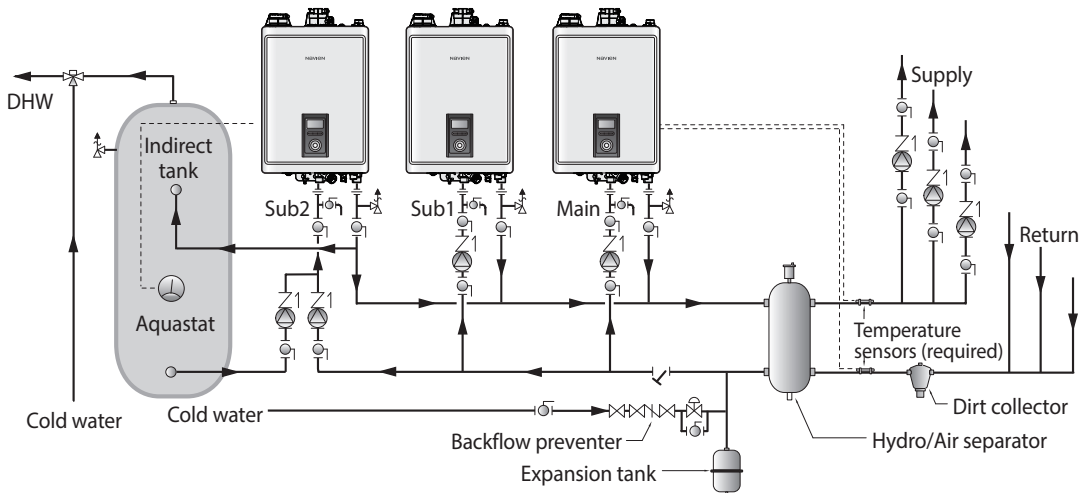

Note

- In this configuration, space heating and DHW can operate simultaneously.
- The aquastat on the DHW indirect tank must be connected to a sub unit.
- If a dedicated sub unit is used, the input capacity requirement of the indirect tank shall not exceed the capacity of the single boiler.
- Connect the DHW pump to the sub unit.
- Connect zone pumps to the zone controller. Do not connect zone pumps to the main or sub units.

8.1.1 Piping Sizes and Considerations

When plumbing a cascade system, consider the following pipe diameters and flow rates. Note that flow rates above 4 ft/s may cause pipe erosion or velocity noise. These specifications may vary depending on installation conditions.

NHB-110H

Qty	Flow Rate (GPM) @ 20°F ΔT	Recommended Boiler Pipe Sizes (2-4 ft/s)
2	32.2	2"
3	48.3	2-½"
4	64.4	3"
5	80.5	3"
6	96.6	3-½"
7	112.7	3-½"
8	128.8	4"
9	144.9	4"
10	161	4"
11	177.1	5"
12	193.2	5"
13	209.3	5"
14	225.4	5"
15	241.5	5"
16	257.6	6"

NHB-150H

Qty	Flow Rate (GPM) @ 20°F ΔT	Recommended Boiler Pipe Sizes (2-4 ft/s)
2	36.6	2"
3	54.9	2-½"
4	73.2	3"
5	91.5	3-½"
6	109.8	3-½"
7	128.1	4"
8	146.4	4"
9	164.7	5"
10	183	5"
11	201.3	5"
12	219.6	5"
13	237.9	5"
14	256.2	6"
15	274.5	6"
16	292.8	6"

8.2 Connecting the Communication Cables

Up to 16 boilers can be connected with Navien Ready-Link communication cables. Select one of the boilers in the cascade system as the main boiler, and then connect the other boilers to it as sub boilers. Before making any connections, ensure that the power is turned off to all boilers.

Connect the Ready-Link cables to the CNK1 terminal strip:

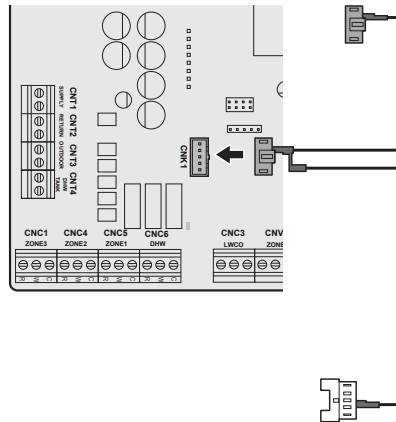

Note When installing the cascade system, refer to “8.1 Connecting Water Supplies”. Also, connect zone pumps to the zone controller. Do not connect zone pumps to the main or sub units.

8.2.1 Configuring the Communication Settings

After connecting the Ready-Link communication cables, restore power to the boiler and turn on all boilers using the Power button (⏻).

Refer to “11.13.4 Configuring a Cascade System” to configure the communication settings.

9. Installing a Common Vent System

9.1 About the Common Vent System

The Navien Common Vent System* provides an easy way to install the vent system for up to 8 Navien NHB-H boiler units. By sharing the main intake and exhaust vent pipes, effective system venting is available with less venting materials and minimal number of penetrations on the walls or roofing.

* Independently tested and approved by CSA

Read all safety messages and carefully follow the guidelines in this manual when installing a common vent system for the NHB-H boiler units.

DANGER

This appliance is certified as a “Category IV” appliance and requires a special venting system. The vent system operates with a positive pressure in the pipe.

To prevent serious injury or death:

- ALWAYS vent exhaust gases directly outdoors using the vent materials and following these instructions.
- DO NOT connect vent connectors serving appliances vented by natural draft into any portion of mechanical draft systems operating under positive pressure.

WARNING

Improper venting of the boiler can result in excessive levels of carbon monoxide and can lead to serious injury or death.

This boiler must be vented in accordance with the “Venting of Equipment” section of the latest edition of the ANSI Z223.1/NFPA 54 Natural Fuel Gas Code in the USA and/or the “Venting systems and air supply for boilers” section of the latest version of the CAN/CGA B149.1 Natural Gas and Propane Installation Code in Canada, as well as all applicable local building codes and regulations.

To prevent serious injury or death:

- ONLY licensed professionals should install venting.
- ALWAYS follow all regulations, codes, and instructions when venting the boiler.
- ALWAYS seal the venting system gastight to prevent flue gas leakage and carbon monoxide emissions.
- The building owner is responsible to maintain the exhaust and intake terminations free of snow, ice, or other potential blockages, as well as scheduling routine maintenance.

9.1.1 Guidelines for a Common Vent System

WARNING

- To ensure the correct operation of the common vent system,
 - a cascade communication cable **MUST** be installed between all units in the common vent system by the installer.
 - backflow vent dampers must be installed in the exhaust duct of each boiler unit.
 - use **direct vent** (with separate intake and exhaust vent) or **indirect vent** (combustion air drawn from room) systems.
- Common vent installations for use with natural gas and propane are only approved for up to 4,500 ft.
- This manual covers the installation of a common vent system for **NHB-H boilers only**.

To ensure the safe and correct installation of the common vent system, carefully follow the instructions and guidelines.

- Check to see if all contents are included in the package (refer to the “Included Items” on page 82).
- A maximum of 8 NHB-H boilers may be connected to one common vent system. In a cascade system that has more than 8 boilers, use 2 common vent systems, or consult Navien.
- Use only the PVC cements specified in this manual when connecting pipes, joints, or elbows.
- Position the boiler units as close as possible to the vent termination.
- Install a new vent system with this appliance. If an existing vent system is reused, thoroughly inspect it for punctures, cracks, or blockages prior to connecting it to the boiler unit.
- Horizontal vent pipe runs must be supported every 4 feet (1.2 m) (minimum). All vertical vent pipe runs must be supported every 6 feet (1.8 m) (minimum). Support the vent pipe with hangers at regular intervals or as required by local codes.
- Install a Navien Backflow Damper Kit for each boiler unit. Use only the damper specified in this manual.
- To avoid moisture and frost build-up and to maintain clearances to openings on adjacent homes, 45° elbows, 90° elbows, or tees may be attached to the end of the termination vent pipe to direct the exhaust plumes away from buildings, as long as the total allowable vent lengths, maximum number of elbows, and distances to air intake restrictions are observed.
- If the boiler units will be installed in areas where snow is known to accumulate, protect the vent termination from blockage. Provide a minimum of 1 foot (30 cm) clearance from the bottom of the exhaust of the expected snow accumulation level. Snow removal may be necessary to maintain clearance.
- Ensure that the vent termination is at least 12 in (300 mm) above ground, 12 in (300 mm) above the highest anticipated snow level, or as required by local codes, whichever is greater.
- Support the vent pipe with hangers at regular intervals or as required by local codes.
- The vent for this appliance shall not terminate over public walkways; or near soffit vents or crawl space vents or a nuisance or hazard or cause property damage; or where condensate or vapor could cause damage or could be detrimental to the operation of regulators, relief valves, or other equipment.

Adequate Installation Clearances

NOTICE

Do not install the boiler on carpeting.

Install the boiler in an area that allows for service and maintenance access to utility connections, piping, filters, and traps. Based on the installation location, ensure that the following clearances are maintained:

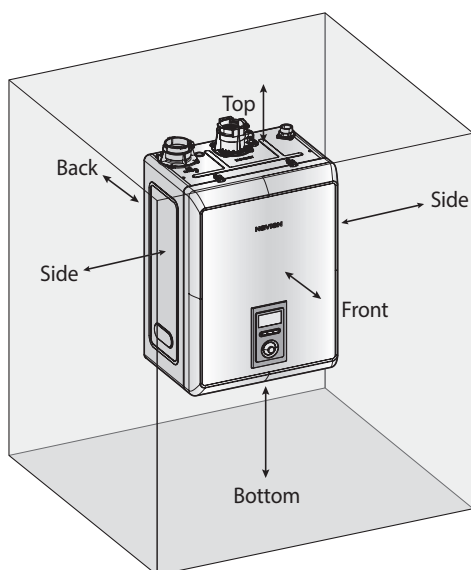

Clearance from:	Indoor Installation
Top	9 in (229 mm) minimum
Back	0.5 in (13 mm) minimum
Front	4 in (100 mm) minimum
Sides	3 in (76 mm) minimum
Bottom	12 in (300 mm) minimum

Note

The recommended clearance from the TOP of the unit is 36" for servicing the common vent. Additionally, the recommended clearance from the FRONT of the unit is 24" for maintaining and servicing.

Clean, Debris and Chemical-free Combustion Air

- Do not install the boiler in areas where dust and debris may accumulate or where hair sprays, spray detergents, chlorine, or similar chemicals are used.
- Do not install the boiler in areas where gasoline or other flammables are used or stored.
- Ensure that combustible materials are stored away from the boiler and that hanging laundry or similar items do not obstruct access to the boiler or its venting.

General and Local Standards Information

When installing and operating the common vent system, the following standards and regulations must be complied with and adhered to:

- Local codes or, in the absence of local codes, the National Fuel Gas Code, ANSI Z223.1/NFPA 54.
- Appliance manufacturer's Installation Instructions.
- Regulations on the supervision of construction.
- Statutory provisions.
- Installation and service work must be carried out by licensed professionals only.

Risk Guidelines

- Ensure that all common vent system components are manufactured and installed in accordance with valid standards, regulations, and safety engineering rules.
- To avoid risk, the common vent system must be installed and used only for the original purpose described in this manual.
- Defects or damages found in a common vent system must be addressed and repaired immediately.
- For roof or chimney modifications, refer to the relevant industrial safety regulations.
- Works on roofs and facades are dangerous. Comply with all relevant regulations.

Cutting and Assembling Common Vent System Components

Standard tools are suitable for the cutting and assembly of common vent system components. Follow the guidelines listed below when working with the components.

- When cutting vent components, ensure that the cuts are straight. Chamfer and deburr all edges before installing the components.
- All vent joints must be fully tightened.
- Before operating the system, ensure that the installed vent system is clean and free of debris.
- Ensure that the vent system is rigidly supported according to the manual's instructions.

Selecting Vent Pipe Materials

Consult the following chart or the most recent edition of ANSI Z223.1/NFPA 54, as well as all applicable local codes and regulations when selecting vent pipe materials. This appliance should be vented with materials approved for Category IV gas appliances. Do not use cellular core PVC (ASTM F891), cellular core CPVC, or Radel® (polyphenolsulfone) for the exhaust vent. See below for recommended vent materials.

Locale	Recommended Vent Materials
USA	<ul style="list-style-type: none"> • PVC Schedule 40 (Solid Core) • CPVC Schedule 40 or 80 (Solid Core) • Approved Polypropylene (Centrotherm Innoflue)
Canada*	ULC-S636 Type BH Special Gas Vent <ul style="list-style-type: none"> • Class IIA (PVC) • Class IIB (CPVC) • Class IIC (Centrotherm Innoflue/ Approved Stainless Steel) (Refer to page 61)

* For installation in Canada, field-supplied plastic vent piping must comply with CAN/CGA B149.1 (latest edition) and be certified to the Standard. For Type BH Gas Venting Systems, ULC-S636. Components of this listed system must not be interchanged with other vent systems or unlisted pipes or fittings. All plastic components and specified primers and glues of the certified vent system must be from a single system manufacturer and must not be intermixed with another system manufacturer's parts. The supplied vent connector and vent termination are certified as part of the boiler.

! WARNING

Carbon Monoxide Hazard

To prevent serious injury or death:

- ONLY use approved venting materials.
- NEVER mix different types of vent pipe materials. The vent system may fail and harmful flue products may leak into the living space.
- The use of more than one type of pipe for the vent piping will void the warranty and certification of the boiler.

Vent Pipe Pitch and Supports

For horizontal runs, slope the horizontal section upward toward the vent termination at a rate of ¼" per foot (2% slope).

Connecting Pipes with Cement

! WARNING

The vapors from primers and solvent cements can make you dizzy and are dangerous to your health. Ensure that the work area is well ventilated, or wear an approved organic vapour respirator when working with primers and solvent cements.

To connect the vent pipes using cement:

1. Spread an even layer of solvent cement on the inside of the pipe fitting and the outside of the pipe.

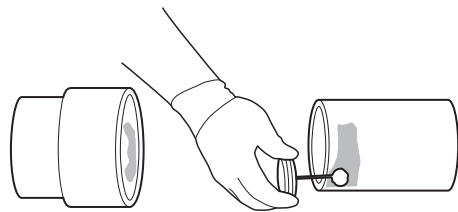

- Align the pipe with the pipe fitting and twist the pipe a quarter turn as you insert it into the fitting. Twisting the pipe spreads the solvent cement evenly to ensure a solid joint.

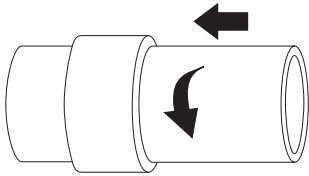

- Hold the pipe and pipe fitting together for about 15 seconds until the cement sets.

Note

- Use approved solvent type cement for the proper vent materials.
- Use solvent type cement only.
- Check the date of manufacture before using the cement. Ensure that cement was not manufactured more than 2 years prior to using it.
- Ensure that the inside of the pipe fitting and the outside of the pipe, where cement will be applied, is clean.
- Apply an even layer of cement over all mating surfaces.
- Use primer in temperatures lower than 32°F (0°C).
- Use solvent cement in room temperatures higher than 32°F (0°C).
- Installing vent pipe with cement in cold ambient temperatures can result in longer cure times.

⚠ WARNING

Carbon Monoxide Hazard

To prevent serious injury or death:

- NEVER apply force or impact to pipes after making connections.
- Excessive force might cause the pipe or fitting to leak harmful gas.

9.1.2 Determining the Length of a Common Vent System

Follow the instructions listed below to determine the length of a common vent.

1. Add the BTU/H input ratings for each unit in the cascading system to determine the total BTU/H rating.
2. Determine the total length (L) of the common vent, which consists of the horizontal width (W) and the vertical height (H): Total length (L) = W + H.

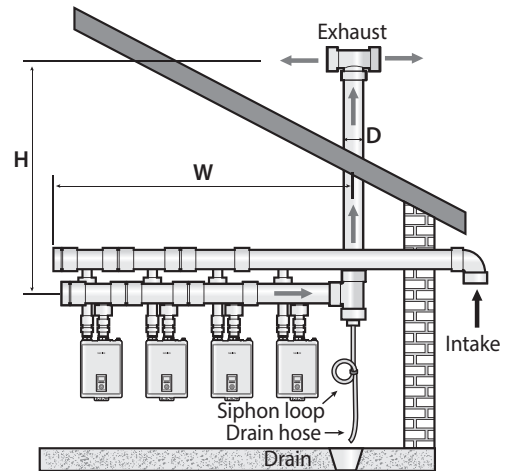

Common Vent Length Table [Total Length (L) = W + H]

Vent Length for NHB-H Boiler Units

Required Load (Total BTU/H)	Model	Total Length (ft)			
	110/150H	D=3"	D=4"	D=6"	D=8"
300,000	2	60	106	200	
450,000	3	40	71	160	
600,000	4	30	53	120	
750,000	5	24	42	96	150
900,000	6		35	80	142
1,050,000	7		30	68	121
1,200,000	8		26	60	106

Note

- Every 90° elbow used is equivalent to 8 linear feet (2.4 m) of vent length.
- Branch pipe lengths are not added to the allowable equivalent vent lengths that are provided in the following charts.

Example of a Typical Installation

The following illustration depicts an example of a common vent system installed for a cascade system of 8 Navien NHB-H boiler units.

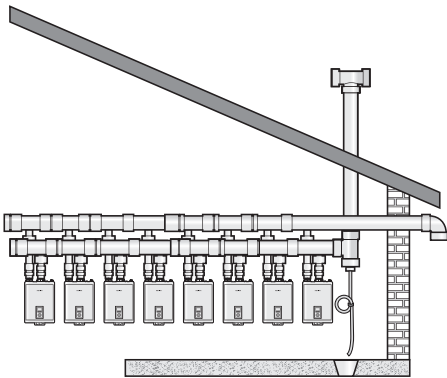

Note

The illustration is intended for reference purposes only.

9.2 Navien Common Vent Collar Kit (Back-draft Damper)

The Navien Common Vent Collar Kit includes a backdraft damper preventing the flue gases and cold outside air from entering the boiler when the combustion fan is off. The kit includes the cascade cable.

By closing the exhaust vent as soon as the combustion cycle ends, the Navien Common Vent Collar Kit retains heat in the system for longer periods.

Included Items

Common Vent Collar Kit	
Installation Manual	
Ready-Link communication cable	
Screw (4 ea)	
VID jumper wire	

Specifications

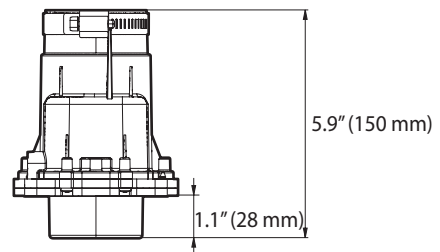

Part Name	Common Vent Collar Kit
Part No.	30014367*
Material	PP (Polypropylene)

Maintenance Port

Navien Common Vent Collar Kit has a maintenance port to allow you to easily inspect the operating condition of the damper plate.

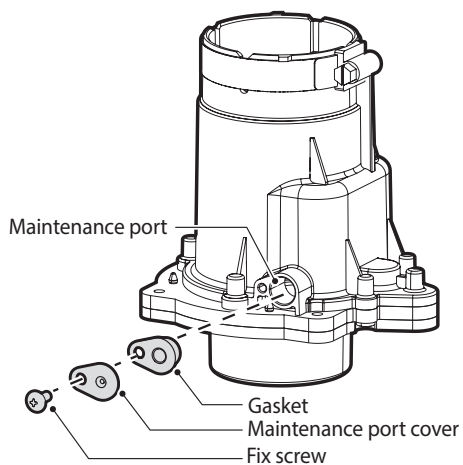
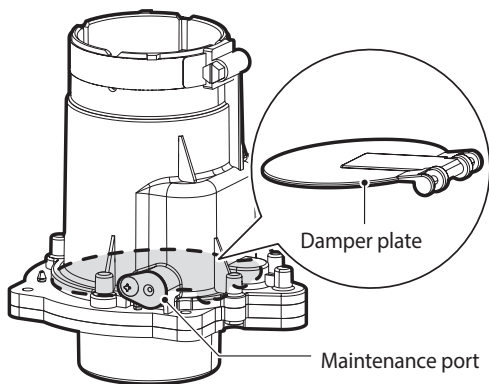

Refer to "9.8 Maintenance" for detailed inspection procedures of the Navien Common Vent Collar Kit (Back-draft Damper).

Note

When using a common vent in a cascade system, backflow devices are required to prevent exhaust from entering the building.

9.3 Starting the Common Vent System

9.3.1 Common Vent Collar Kit Assembly

Follow the instructions below to assemble the Common Vent Collar Kit on the NHB-H boiler unit:

1. Remove the screws from the exhaust vent adapter.

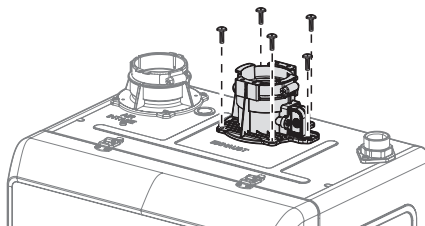

2. Detach the exhaust vent adapter from the top of the unit. Disconnect the Vent Installation Detector (VID) wiring from the harness.

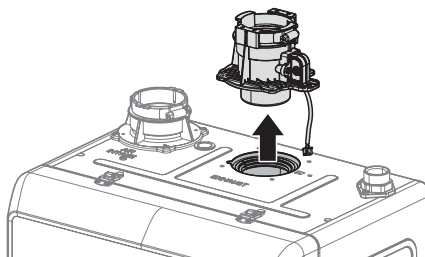

3. Connect the Common Vent Collar Kit to the exhaust duct of the boiler unit.

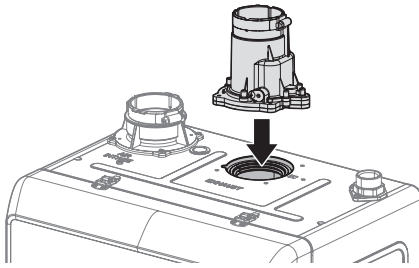

4. Tighten the four mounting screws to secure the Common Vent Collar Kit in place. The screws (x 4) are supplied with the Common Vent Collar Kit.

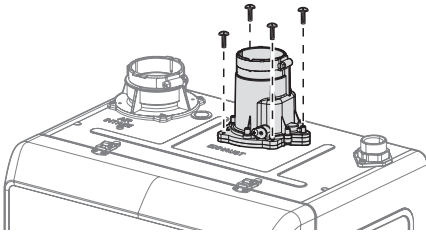

⚠ WARNING

If the original vent collar must be repaired or reassembled, ensure that it is tightened by using the 4 provided screws.
Improper installation of the vent collar may result in serious injury or death.

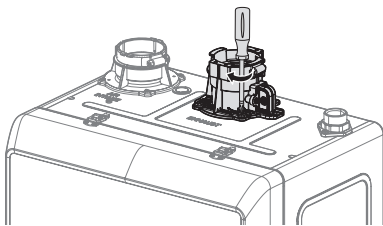

5. Remove the front cover of the boiler, and connect the provided VID jumper wire as shown below. You must connect it to the wire with the "VID" label.

Note The Damper includes a VID jumper wire.

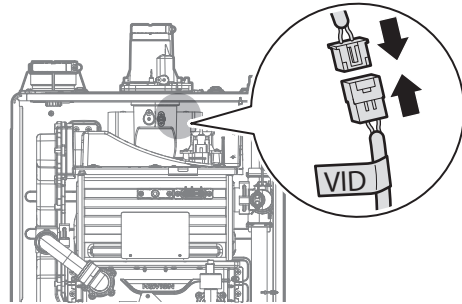

9.3.2 Connecting the Pipe to the Common Vent Collar Kit

⚠ WARNING

ALWAYS properly cut the pipe at a 90° angle and deburr the vent pipe before installing so the pipe is fully connected to the exhaust gas vent fitting.

Use water (NOT grease) to lubricate the end of the vent pipe before inserting into the Common Vent Collar.

ALWAYS insert the vent pipe 1.5 in (38 mm) into the Common Vent Collar using a twisting motion until the end reaches the bottom of the socket.

If flue gas leaks, inhalation of carbon monoxide may result in serious injury or death.

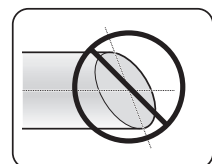
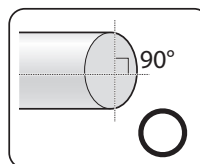
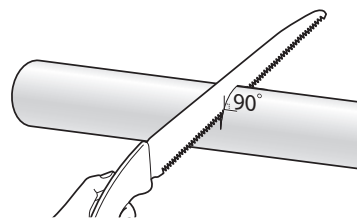

Note Do not use primer or cement on the appliance connection.

1. Measure 1-1/2" from the end of the vent pipe, then draw a mark at that distance.

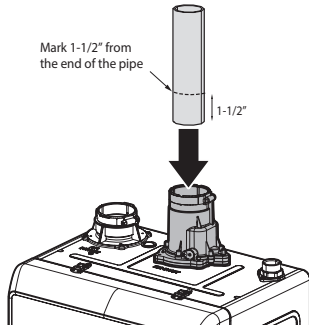

2. Insert the vent pipe into the vent collar to start the vent run. Make sure to completely slide the vent into the collar until the end makes contact with the bottom of the socket.

Note Verify that 1-1/2" of the pipe has been completely inserted into the collar and that the mark is no longer visible.

3. Tighten the clamp with a socket wrench (8 mm) to properly seal the joint.

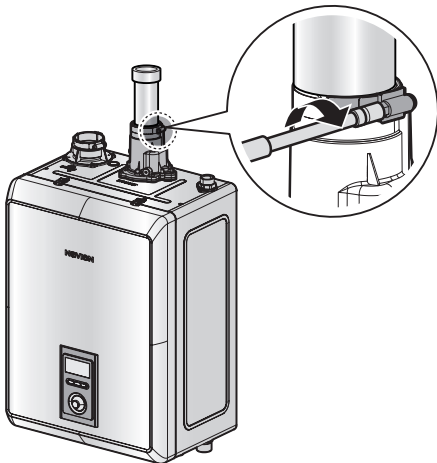

! WARNING

NEVER start the vent run with a **street elbow** at the vent collar to prevent serious injury or death. Using an elbow directly at the collar will not allow for a tight seal between the appliance and the vent pipe.

ALWAYS use a length of straight pipe when starting the vent run.



Note The length of vent pipe from the unit to the common vent main trunk pipe must not exceed 16' of equivalent length.

9.3.3 Assembling the Wye Joint

1. Assemble the hub wye, the 2" reducer, and the 90° elbow into the common vent. You can also use the hub reducing wye and the 90° elbow to assemble the common vent. Apply the proper solvent cement to the mating surfaces.

Note Tees can also be used instead of wye fittings as part of the common vent.

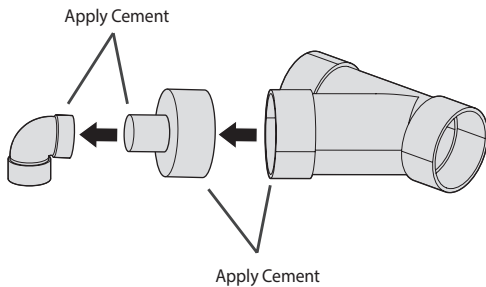

[Hub Wye, 2" Reducer, 90° Elbow]

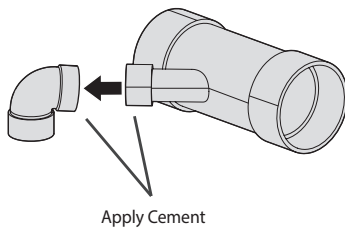

[Hub Reducing Wye and 90° Elbow]

Note Multiple reducers can be used to allow proper connection of 2" vent pipe to the common vent system.

2. Assemble the wye joint or wye assembly to the vent pipe. Apply solvent cement to the mating surfaces.

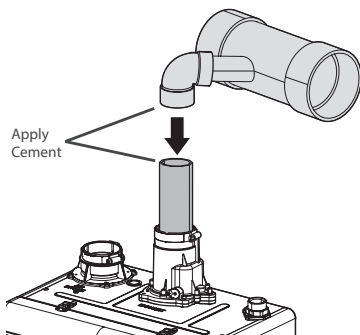

[Hub Wye Assembly]

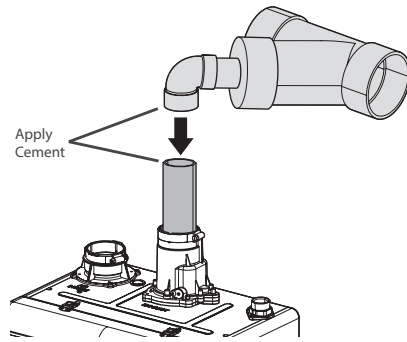

[Hub Reducing Wye Assembly]

Note The options shown here are only examples. The setup you choose will vary based on the installation location, local building codes, and other factors. The installer is responsible for all equipment and detailing required by local codes.

⚠ WARNING

Carbon Monoxide Hazard

To prevent serious injury or death:

- ALWAYS use a bubble test kit to check for leaks.
- After the boiler is installed, fill with water, turn on the boiler and test for leaks using a bubble test kit.
- If you see bubbles form, you will need to repair that section of pipe and bubble test again.

9.4 Connecting and Terminating the Vent Pipe

Refer to the following example to install the common vent system. The installation area should be measured to ensure that sufficient space is available to install the boiler units and the common vent system. Ensure that the common vent system is installed near the boiler units while satisfying all clearance requirements that are specified in this manual as well as the Installation Manuals supplied with the boiler units.

9.4.1 Connecting the Main Pipe Runs to Wye Joint or Wye Assembly

After connecting the wye joint or wye assembly, connect the main trunk pipe to each side of the wye joint or wye assembly. Each trunk pipe is connected to the other wye joint or wye assembly. Refer to “Connecting Pipes with Cement” on page 80 for more information.

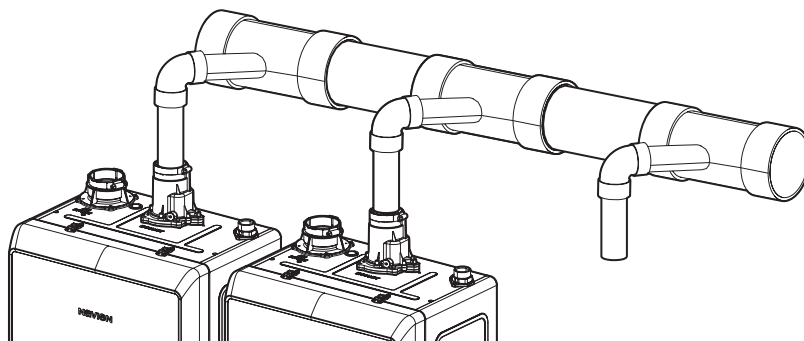

⚠ WARNING

Carbon Monoxide Hazard

To prevent serious injury or death:

- ALWAYS use a bubble test kit to check for leaks.
- After the boiler is installed, fill with water, turn on the boiler and test for leaks using a bubble test kit.
- If you see bubbles form, you will need to repair that section of pipe and bubble test again.

9.4.2 Installing the System Termination

End caps, pipe elbows or tee joints can be used at the open ends of the intake and exhaust vent pipes. Refer to the following installation examples that depict how the parts are fitted at the end of the common vent system piping.

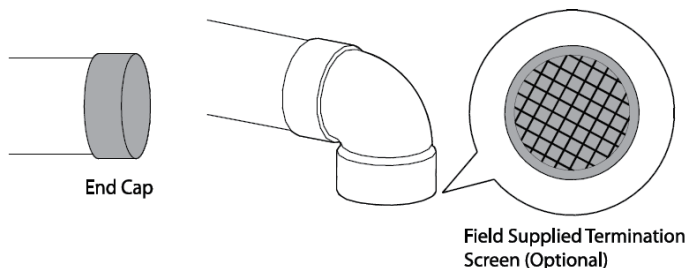

Note

The illustration is intended for reference purposes only.

Direct Venting

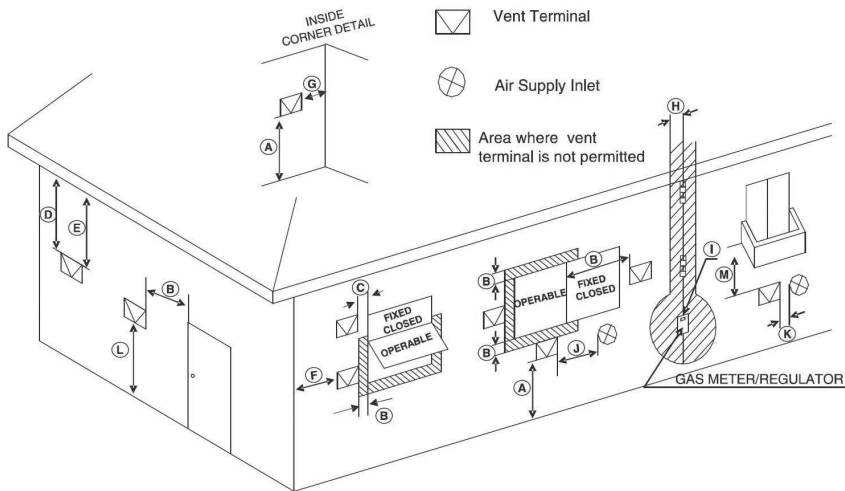

Ref	Description	Canadian Direct Vent Installations ¹	US Direct Vent Installations ²
A	Clearance above grade, veranda, porch, deck, or balcony	12 in (30 cm)	12 in (30 cm)
B	Clearance to window or door that may be opened	36 in (91 cm)	12 in (30 cm)
C	Clearance to permanently closed window	12 in (30 cm)*	12 in (30 cm)*
D	Vertical clearance to ventilated soffit located above the terminal within a horizontal distance of 2 ft (61 cm) from the center line of the terminal	3 ft (91 cm)*	3 ft (91 cm)*
E	Clearance to unventilated soffit	3 ft (91 cm)*	3 ft (91 cm)*
F	Clearance to outside corner	2 ft (61 cm)*	2 ft (61 cm)*
G	Clearance to inside corner	12 in (30 cm)*	12 in (30 cm)*
H	Clearance to each side of center line extended above meter/regulator assembly	3 ft (91 cm) within a height 15 ft above the meter/regulator assembly	3 ft (91 cm) within a height of 15 ft (4.6 m)*
I	Clearance to service regulator vent outlet	3 ft (91 cm)	3 ft (91 cm)*
J	Clearance to nonmechanical air supply inlet to building or the combustion air inlet to any other appliance	36 in (91 cm)	12 in (30 cm)
K	Clearance to a mechanical air supply inlet	6 ft (1.83 m)	3 ft (91 cm) above if within 10 ft (3 m) horizontally
L	Clearance above paved sidewalk or paved driveway located on public property	7 ft (2.13 m) [†]	7 ft (2.13 m) [†]
M	Clearance under veranda, porch deck, or balcony	12 in (30 cm) [‡]	12 in (30 cm) - open on 3 sides*

¹ In accordance with the current CSA B149.1 Natural Gas and Propane Installation Code

² In accordance with the current ANSI Z223.1/NFPA 54 National Fuel Gas Code

[†] A vent shall not terminate directly above a sidewalk or paved driveway that is located between two single family dwellings and serves both dwellings.

[‡] Permitted only if veranda, porch, deck, or balcony is fully open on a minimum of two sides beneath the floor.

*Suggested clearances by the manufacturer. If the clearances required by local codes are different from those from the table above, the greater clearance should apply.

Indirect Venting

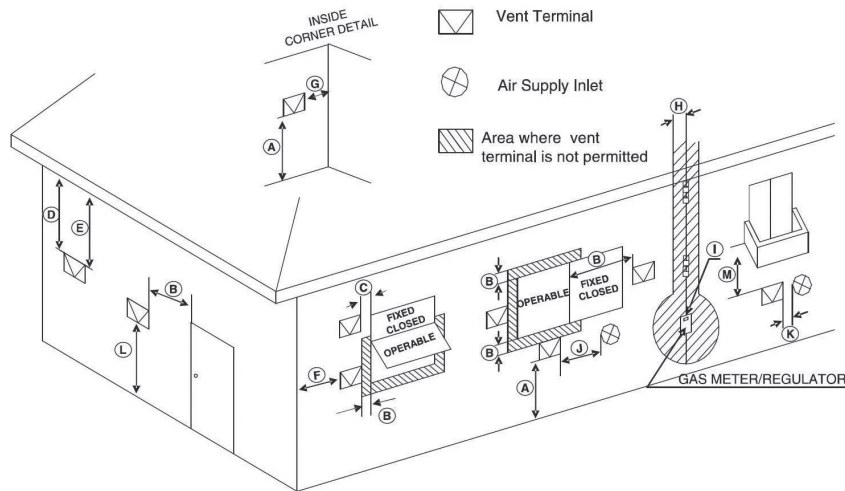

Ref	Description	Canadian Non-Direct Vent Installations ¹	US Non-Direct Vent Installations ²
A	Clearance above grade, veranda, porch, deck, or balcony	12 in (30 cm)	12 in (30 cm)
B	Clearance to window or door that may be opened	36 in (91 cm)	48 in (120 cm) below or to side of opening; 12 in (30 cm) above opening
C	Clearance to permanently closed window	12 in (30 cm)*	12 in (30 cm)*
D	Vertical clearance to ventilated soffit located above the terminal within a horizontal distance of 2 feet (61 cm) from the center line of the terminal	3 ft (91 cm)*	3 ft (91 cm)*
E	Clearance to unventilated soffit	3 ft (91 cm)*	3 ft (91 cm)*
F	Clearance to outside corner	2 ft (61 cm)*	2 ft (61 cm)*
G	Clearance to inside corner	12 in (30 cm)*	12 in (30 cm)*
H	Clearance to each side of center line extended above meter/regulator assembly	36 in (91 cm) within a height 15 ft (4.57 m) above the meter/regulator assembly	3 ft (91 cm) within a height of 15 ft (4.6 m)*
I	Clearance to service regulator vent outlet	36 in (91 cm)	3 ft (91 cm)*
J	Clearance to non-mechanical air supply inlet to building or the combustion air inlet to any other appliance	36 in (91 cm)	48 in (120 cm) below or to side of opening; 12 in (30 cm) above opening
K	Clearance to a mechanical air supply inlet	6 ft (1.83 m)	36 in (91 cm) above if within 10 ft (3 m) horizontally
L	Clearance above paved sidewalk or paved driveway located on public property	7 ft (2.13 m) [†]	7 ft (2.13 m) [†]
M	Clearance under veranda, porch deck, or balcony	12 in (30 cm) [‡]	12 in (30 cm) - open on 3 sides*

¹ In accordance with the current CSA B149.1 Natural Gas and Propane Installation Code

² In accordance with the current ANSI Z223.1/NFPA 54 National Fuel Gas Code

[†] A vent shall not terminate directly above a sidewalk or paved driveway that is located between two single family dwellings and serves both dwellings.

[‡] Permitted only if veranda, porch, deck, or balcony is fully open on a minimum of two sides beneath the floor.

* Suggested minimum clearances by the manufacturer. If the clearances required by the local authority or gas supplier are different from those from the table above, the greater clearance should apply.

9.5 Setting up the Common Vent System

⚠ WARNING

Electric Shock Hazard

To prevent serious injury or death:

- ALWAYS disconnect power before servicing.
- NEVER turn power on until the electrical wiring installation is complete.
- NEVER remove front cover unless power to unit is turned off or disconnected.

Refer to the following figures when setting the common vent type.

To view and configure the cascade settings, press the Back button (↩) and the Menu button (M) simultaneously for 3 seconds, and then select "4. Cascade Status and Settings".

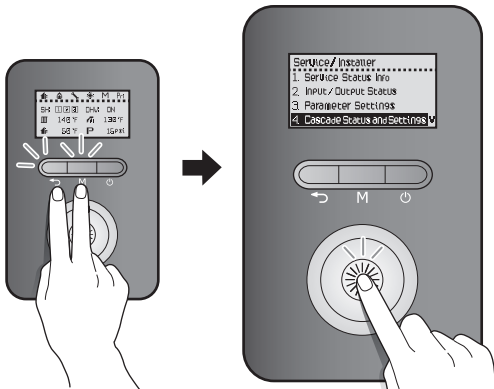

Rotate the Command dial (⊙) to switch between the parameters or to increase/decrease setting values. Press the Command dial (⊙) to select "8. Vent Type Setting".

Note

For more information on the vent type settings, refer to "11.13.4 Configuring a Cascade System" on page 114.

9.6 Common Vent Termination Clearances

9.6.1 Direct Vent Application – Vertical Installation

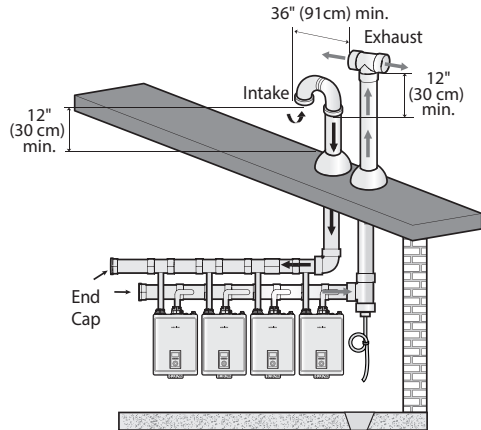

9.6.2 Venting Intake and Exhaust to Different Locations

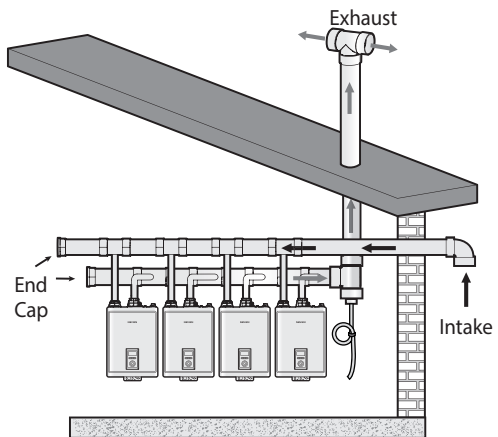

9.6.3 Horizontal Intake and Exhaust Termination

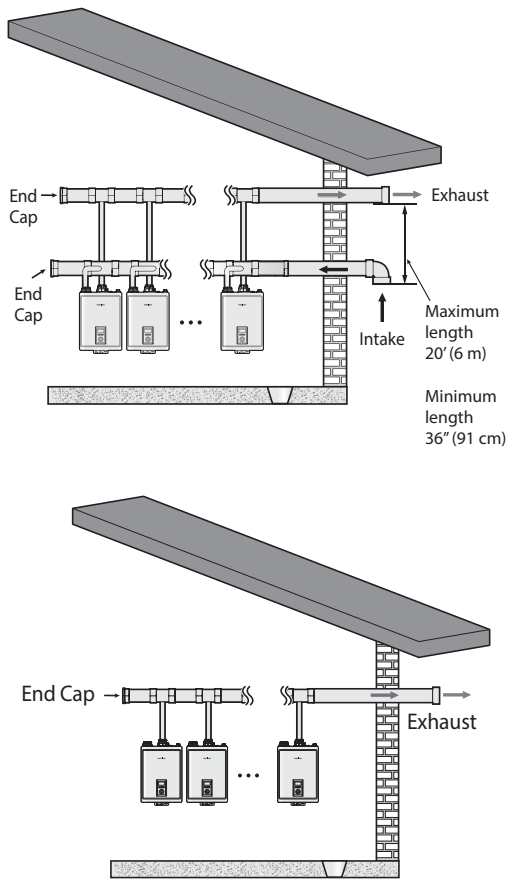

In cases where a 12" horizontal clearance is not possible, provide a vertical clearance of at least 36" with the exhaust above the intake but do not exceed 20'.

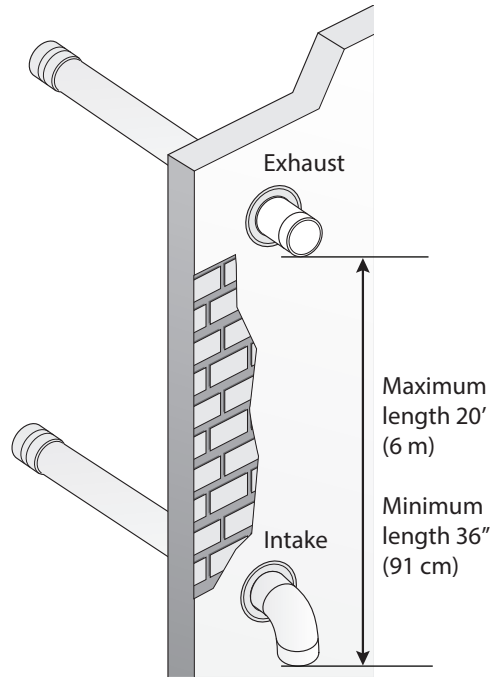

Note

- The illustration is intended for reference purposes only.
- Direct the exhaust away from any building openings.
- During cold weather situations, the temperature of the exhaust will be much warmer than the ambient air. Therefore, you will see water vapor being produced at the termination.

9.6.4 Direct Vent Application – Horizontal Installation

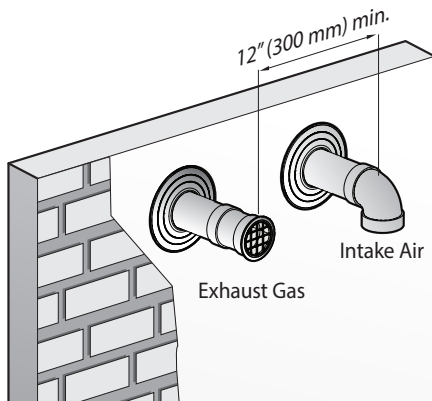

9.7 Installing a Condensate Drain

Refer to the following examples to install a condensate drain hose (field supplied) to the common vent system. The condensate drain hose prevents condensate or rain from entering the exhaust system and gathering above the backflow damper.

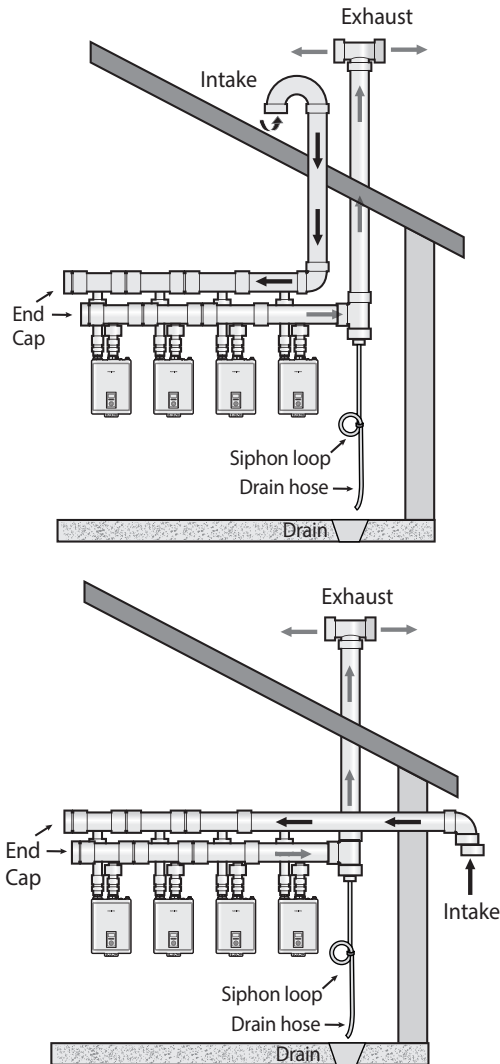

Note

Condensate drains can also be added to the end caps for additional drainage.

To install a condensate drain to the common vent system:

1. Form a loop with a drain hose and fix it with a tie.

Note

- While shaping the hose, do not bend the hose excessively. The hose will be deformed and the flow will be restricted if the hose is bent in sharp angles.
- Do not fix the hose too tight when tying the hose to form the loop. The hose will be deformed and the flow will be restricted if the tie is too tight.

2. Prime the loop using tap water.
3. Install the hose to the common vent system and direct the end of the hose to a drain.

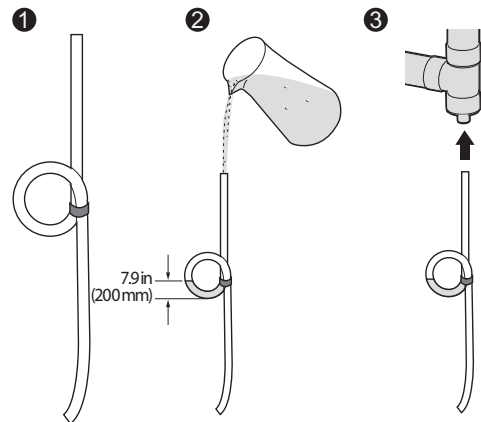

WARNING

Carbon Monoxide Hazard

Check the loop again to ensure the water is still in the loop.

The loop (siphon) must be primed with water before running the system to prevent toxic exhaust gas from leaking and resulting in serious injury or death.

9.8 Maintenance

Periodically check the damper condition inside the Common Vent Collar Kit through the maintenance port to ensure optimal performance of the system. Follow the instructions to check the damper condition and replace the Common Vent Collar Kit if necessary.

1. Remove the screw that fixes the maintenance port cover to the Common Vent Collar Kit, and then remove the gasket and the maintenance port cover.

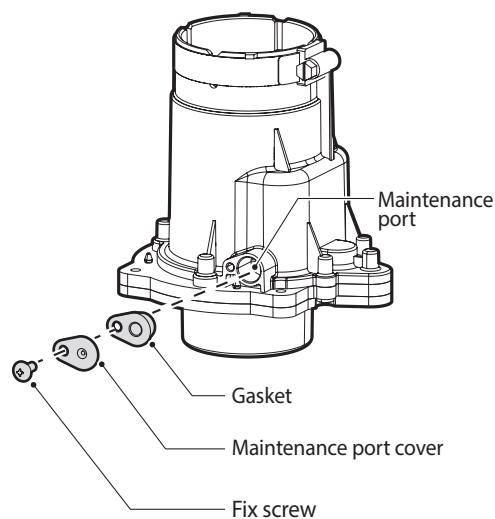

2. Through the maintenance port, check the operating condition of the damper plate inside the Common Vent Collar Kit.

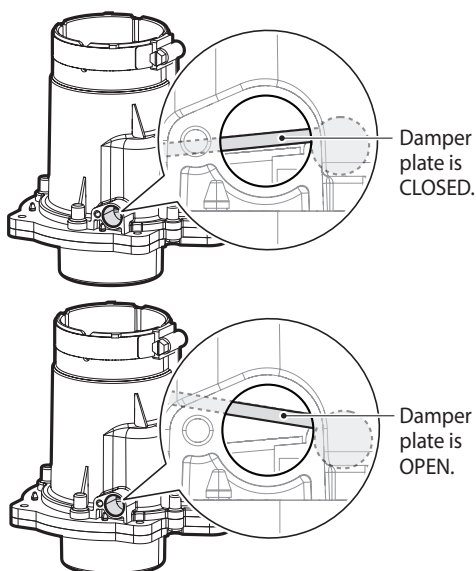

3. Reinstall the gasket and maintenance port cover, and then fix them with a set screw.

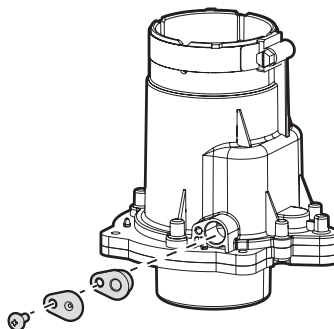

Note If condensate comes out the port when opened, check for proper drainage or any blockage.

4. Visually inspect the maintenance port to ensure that the gasket is properly installed between the maintenance port and the maintenance port cover.

⚠ WARNING

Carbon Monoxide Hazard

To prevent serious injury or death, ALWAYS check the gasket is properly installed under the maintenance port cover after checking the operating condition of the damper plate through the maintenance port.

Harmful exhaust gas may leak if the gasket is not installed, or if it is not installed properly.

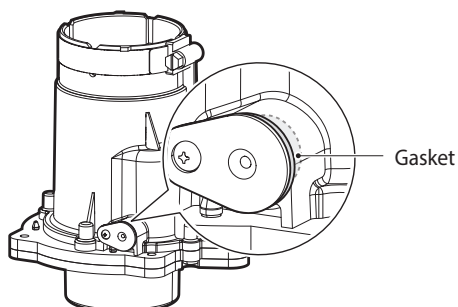

10. Installation Checklist

After installing the boiler, review the following checklist. You should be able to answer “Yes” to all of the items in the checklist. If not, review the appropriate sections to complete the installation. To troubleshoot any operational problems refer to “Troubleshooting” in the User’s Information Manual.

If you have additional questions or need assistance with installation, contact Technical Support at 1-800-519-8794 or 1-949-420-0420, or refer to the technical support section of Navien’s website (www.navieninc.com).

Installing the boiler	Yes	No
Have you maintained the required clearances from building openings and intake air vents?		
Have you minimized the distance between the boiler and the vent termination?		
Have you maintained the proper service and maintenance clearances?		
Is the make-up air supply sufficient for proper operation?		
Is the make-up air supply free from dust, dirt, corrosive elements, and flammable vapors?		
Is the boiler and vent piping clear of combustibile materials, including clothing, cleaning materials, and rags?		

Connecting the Gas Supply	Yes	No
Does the gas supply match the type specified on the boiler’s rating plate?		
Is the gas line at least ½ or ¾ in ID (Inner Diameter)?		
Is the gas supply line sufficient in length and diameter to deliver the required BTUs?		
Have you measured the pressure of the gas supply line?		
Is the gas supply pressure within the recommended ranges specified in this manual?		
Is the gas supply line equipped with a manual shut-off valve?		
Have you tested the gas line pressure and all fittings for leaks?		
Has the gas company inspected the installation, if required?		

Connecting the Space Heating Piping	Yes	No
Has the system been filled (less than 30 psi) and purged of air?		
Does the piping incorporate means for air removal (scoop, separator, etc.)?		
Is there an expansion tank installed and set to the proper system pressure?		
If glycol is used, is it propylene at a concentration of 35% or less?		
If an external low water cut off (LWCO) is installed, is it wired to the boiler?		

Connecting a Pressure Relief Valve	Yes	No
Have you installed an approved pressure relief valve on the boiler?		
Does the rating of the pressure relief valve match or exceed the maximum BTU rating of the boiler?		
Is the pressure relief valve ¾ in on the space heating outlet?		
Have you installed the pressure relief valve on the space heating supply pipe near the boiler?		
Have you installed a discharge drain tube from the pressure relief valve to within 6-12 in (150-300 mm) of the floor?		

Connecting the Condensate Drain	Yes	No
Have you installed a condensate drain line from the boiler to a drain or laundry tub?		

Venting the boiler	Yes	No
Have you vented the boiler with 2 in or 3 in PVC, CPVC, polypropylene, Type BH Special Gas Vent (ULC-S636) for Category IV boilers (Canada), or in accordance with all local codes and the guidelines in this manual?		
Have you ensured that ABS or PVC cellular core pipe has not been used as venting for the boiler?		
Is the vent sloped upward toward the vent termination at a rate of ¼ in per foot (2% grade)?		
Are all vent runs properly supported?		
Is the vent termination properly supported?		
Are the air intake and exhaust connections on the flue and vent lines correctly sealed?		
Have you installed termination screen caps on the exhaust and intake pipes?		
Have you checked the venting for leaks?		
Is the vent termination at least 12 in (300 mm) above the exterior grade?		
Have you ensured that sufficient make-up air is available?		
Is the total vent length within the maximum vent length restriction?		

Connecting the Power Supply	Yes	No
Is the supplied voltage 110-120V AC?		
Is the boiler plugged into a properly grounded outlet?		
If you have made a direct power supply connection, have you installed a power switch to facilitate end-user maintenance?		
Have you checked the polarity of the electrical connection?		

PCB DIP switch setting (DIP SW2 (Set of 8 Switches))	Yes	No
Gas type: Is switch #1 set correctly for LP (ON) or NG (OFF)?		
If continuous boiler operation is required, is switch #7 in the up (ON) position?		
If high temperature venting has been installed (CPVC or polypropylene), is switch #8 in the up (ON) position?		

Operating the boiler	Yes	No
Have you given the Installation and Operation Manual and User's Information Manual to the owner for future reference?		
Have you shown the owner how to shut off the gas in case of an emergency?		

11. Operating the Boiler



11.1 Operating the Boiler for the First Time

FOR YOUR SAFETY READ BEFORE OPERATING

WARNING: If you do not follow these instructions exactly, a fire or explosion may result, causing property damage, personal injury or loss of life.

- A. This appliance does not have a pilot. It is equipped with an ignition device which automatically lights the burner. Do NOT try to light the burner by hand.
- B. BEFORE OPERATING, smell all around the appliance area for gas. Be sure to smell next to the floor because some gas is heavier than air and will settle on the floor.
WHAT TO DO IF YOU SMELL GAS
 - Do NOT try to light any appliance.
 - Do NOT touch any electrical switch.
 - Do NOT use any phone in your building.
 - Immediately call your gas supplier from a neighbor's phone. Follow the gas supplier's instructions.
 - If you cannot reach your gas supplier, call the fire department.
- C. Use only your hand to push in or turn the gas control knob. Never use tools. If the knob will not push in or turn by hand, don't try to repair it, call a licensed professional. Force or attempted repair may result in a fire or explosion.
- D. Do not use this appliance if any parts have been under water. Immediately call a licensed professional to inspect the appliance and to replace any part of the control system and any gas control which has been under water.

OPERATING INSTRUCTIONS

- 1. STOP! Read the safety information above this label.
- 2. Turn off all electrical power of the appliance.
- 3. Set the thermostat or other operating control to the lowest setting.
- 4. This appliance is equipped with an ignition device which automatically lights the burner.
Do NOT try to light the burner by hand.
- 5. Close the main gas shut off valve. 
- 6. Wait (5) minutes to clear out any gas. Then smell for gas around the appliance and near the floor.
If you smell gas, STOP! Follow "B" in the safety information above.
If you don't smell gas, go to the next step.
- 7. Open the main shut off valve. 
- 8. Turn on the appliance.
- 9. Set the thermostat or other operation control to desired setting.
- 10. If the appliance will not operate, follow the instructions "To Turn Off Gas To Appliance" and call your service technician or gas supplier.

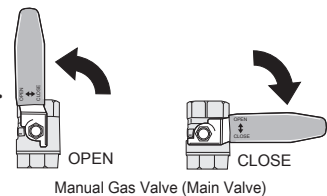

TO TURN OFF GAS TO APPLIANCE

- 1. Turn off all electric power to the appliance if service is to be performed.
- 2. Set the thermostat or other operating control to the lowest setting.
- 3. Close the main gas shut off valve. 

⚠ WARNING

To prevent death, serious injury, or property damage:

- Ensure that the boiler is filled with water before turning on the boiler for the first time. Turning on a boiler that is not filled will damage the boiler and result in property damage, severe personal injury, or death. Such damage is not covered by warranty.
- At initial fill up and during boiler startup and testing, check system thoroughly for leaks. Repair all leaks before proceeding further.
- Before starting the boiler, smell near the floor and around the boiler for gas odorant or any unusual odor. Remove the boiler front door and smell interior of boiler enclosure. Do not proceed with startup if there is any indication of a gas leak.
- If overheating occurs or the gas supply fails to shut off, do not turn off electrical power to the circulating pump. Turning off the circulation pump may aggravate the problem and increase the chance of boiler damage. Instead, shut off the gas supply to the boiler at the manual gas valve.
- If any part of the appliance has been submerged in water, do not use this appliance and immediately call a qualified service technician. The appliance must be replaced if it has been submerged. Attempting to operate an appliance that has been submerged could create numerous harmful conditions, such as a potential gas leakage causing a fire and/or explosion, or the release of mold, bacteria, or other harmful particulates into the air. Operating a previously submerged appliance could result in property damage, severe personal injury, or death.
- Do not try to light the burner manually. This appliance is equipped with an electronic ignition device which automatically lights the burner.

11.2 Turning the Boiler On or Off

To turn the boiler on or off, press the Power button (⏻).

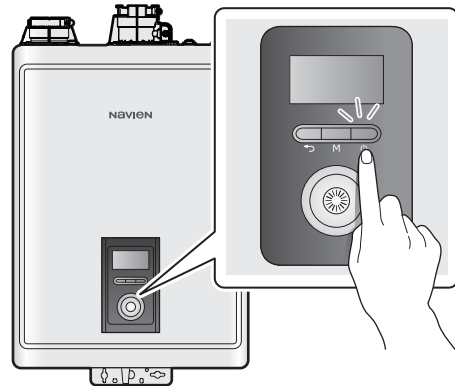

When the power is on, the boiler automatically enters normal operation mode, and the boiler's operating conditions are displayed on the screen.

Note

The boiler status icons remain displayed when the boiler is turned off.

11.3 Start-Up Wizard

The start-up wizard should run the first time the unit is powered on. The wizard must be completed before the boiler can be used.

1. Set the language.
 - English
 - French
 2. Set the time.
 - YYYY:MM:DD:HH:MM:SS
 3. Set the units to display.
 - Celsius (°C), L/M, Meter
 - Fahrenheit (°F), GPM, Feet
 4. Check the gas type.
 - Natural Gas
 - Propane Gas
 5. Installation Elevation Check.
Displays the altitude setting using the main DIP switch.
 6. Set the zone system.
 - Zone Pump System
 - Zone Valve System
 - 6-1. Pump 1 Settings (When Zone System is Zone Pump System)
 - Zone 1 Pump
 - DHW Pump
 7. Set the outdoor reset ON/OFF.
 - Enable
 - Disable
 - 7-1. Set the outdoor reset curve (Enable select).
 - Finned Tube Baseboard
 - FAN Coil
 - Cast Iron Baseboard
 - Low mass Radiant
 - High mass Radiant
 - Radiator
 - Custom
 - 7-2. Set the outdoor high temp.
 - 7-3. Set the outdoor low temp.
 - 7-4. Set the WWSD temp.
8. Set the DHW Call Signal.
 - DHW Thermostat
 - DHW Tank Sensor
 9. Setup Summary
Once the start-up Wizard is finished, a summary of the settings will be displayed. Press the OK button (OK) at each summary screen until the air purge mode is displayed. Settings made in the start-up Wizard can be adjusted from the Main Menu and Installer Menu as described in Section 11.5 and 11.6.

11.4 Adjusting the System Temperatures

Navien NHB-H boilers include multi-temperature zone priority feature that allows the boiler to operate at up to 3 different temperatures. This built-in feature can be accessed from the front panel and eliminates the need for additional accessories that are typically required for multi-temperature applications when used with a combination of heating sources such as baseboard, in-floor heating, and/or an indirect DHW tank.

The boiler can be set up to adjust the priority based on the desired zone temperatures.

In normal operation mode, space heating temperature for each zone can be set depending on the settings in the following table.

Settings			Space heating settings
Zone Priority Settings	Zone Settings	Pump 1 Settings	
Disable	N/A	N/A	Space heating temperature settings
Enable	Zone Pump System	DHW Pump	Space heating temperature settings for Zone 2 and Zone 3 ("Pump 1 Settings" is set to "DHW Pump".)
Enable	Zone Pump System	Zone1 Pump	Space heating temperature settings for Zone 1, Zone 2 and Zone 3
Enable	Zone Valve System	DHW Pump (Default)	Space heating temperature settings for Zone 1, Zone 2 and Zone 3

For more information on the zone settings and zone priority settings, refer to "11.8 Setting the Space Heating Operation" on page 104.

11.4.1 Adjusting the Space Heating Temperature (When "3. Zone Priority Setting" is disabled)

To adjust the heating temperature:

1. In normal operation mode, rotate the Command dial (🌀). The space heating temperature (📊) is highlighted on the screen.

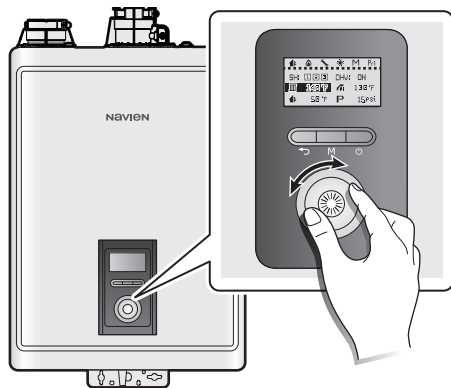

2. Press the Command dial (🌀) to select the space heating temperature. The highlighted section will flash.

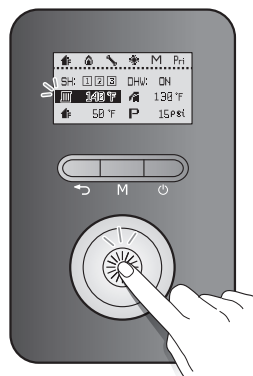

3. Rotate the Command dial (🌀) to the right or left to increase or decrease the temperature.
4. Press the Command dial (🌀) to confirm the new temperature.
5. Press the Back button (↶) to return to normal operation mode, or rotate the Command dial (🌀) to adjust other operation conditions.

You can adjust the temperature while the highlighted section is flashing. Once the flashing stops, the current temperature setting is stored.

11.4.2 Adjusting the Space Heating Temperature (When “3. Zone Priority Setting” is enabled)

To adjust the heating temperature:

1. In normal operation mode, rotate the Command dial (☀️). The space heating temperature (📊) is highlighted on the screen.

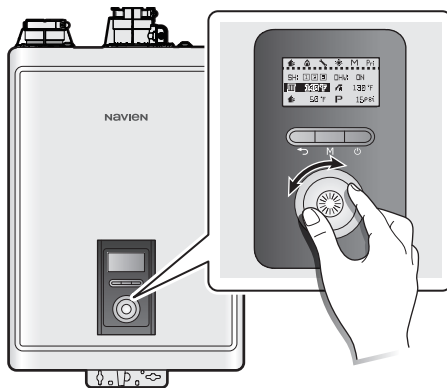

2. Press the Command dial (☀️) to select the desired zone, and then press the Command dial (☀️). The selected zone's temperature will flash.

Note The number of the zones differs depending on the zone settings and Pump 1 settings.

Zone Settings	Pump1 Settings	Space heating settings for each zone
N/A	N/A	Space heating temperature settings
Zone Pump System	DHW Pump	Space heating temperature settings for Zone 2 and Zone 3 (Pump 1 Settings" is set to "DHW Pump").
Zone Pump System	Zone1 Pump	Space heating temperature settings for Zone 1, Zone 2 and Zone 3
Zone Valve System	DHW Pump (Default)	Space heating temperature settings for Zone 1, Zone 2 and Zone 3

For more information on the zone settings and zone priority settings, refer to “11.8 Setting the Space Heating Operation” on page 104.

3. Rotate the Command dial (☀️) to the right or left to increase or decrease the selected zone's space heating temperature.
4. Press the Command dial (☀️) to confirm the new temperature.
5. Press and hold the Command dial (☀️) for more than 2 seconds to return to normal operation mode, or rotate the Command dial (☀️) to adjust another zone's temperature.

- Note**
- The space heating temperature cannot be adjusted when the Outdoor Reset Control is used.
 - The space heating temperature cannot be adjusted if the boiler is operating as a sub unit in a cascade system. The main unit's set temperature will be displayed on the screen.
 - In case of outdoor reset sensor malfunction, the boiler will operate at this set temperature.
 - Take note of the original heating temperature in case you want to restore it to the default.
 - The default space heating supply water temperature range is 104°F (40°C, Absolute MIN) to 180°F (82°C, Absolute MAX).
 - The default space heating return water temperature range is 86°F (30°C, Absolute MIN) to 149°F (65°C, Absolute MAX).
 - You can adjust the temperature ranges in the parameter settings menu.
 - The boiler will retain your settings during a power outage.

11.4.3 Adjusting the DHW Indirect Supply Temperature

⚠ DANGER

Water temperatures at or above 125°F (52°C) can cause instant scalding, severe burns, or death. Before you decide to change the temperature setting, read the following table carefully.

Water Temperature	Time in which a young child can suffer a full thickness (3rd degree) burn
160°F (70°C)	Less than 1 second
140°F (60°C)	1 second
130°F (55°C)	10 seconds
120°F (49°C)	10 minutes
100°F (37°C)	very low scald risk

To adjust the water temperature:

1. In normal operation mode, rotate the Command dial (🌀). The space heating temperature (III) is highlighted on the screen.

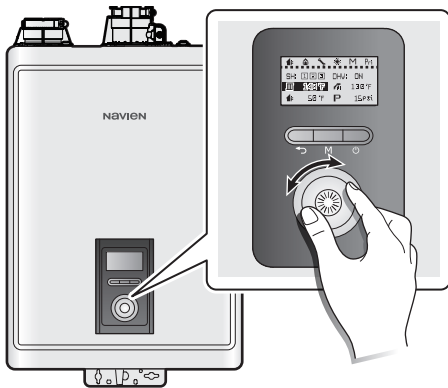

2. Rotate the Command dial (🌀) to the right to select the DHW temperature.



3. Press the Command dial (🌀) to select the indirect DHW temperature (🌀). The highlighted section will flash.



4. Rotate the Command dial (🌀) to the right or left to increase or decrease the temperature.
5. Press the Command dial (🌀) to confirm the new temperature.
6. Press the Back button (↶) to return to normal operation mode, or rotate the Command dial to adjust other operation conditions.

You can adjust the temperature while the display is flashing. Once the display stops flashing, the current temperature setting is stored.

Note

- Take note of the original DHW indirect supply temperature in case you want to restore it to the default.
- The default DHW temperature range is 104°F (40°C, Absolute MIN) to 180°F (82°C, Absolute MAX).
- You can adjust the temperature ranges in the parameter settings menu.
- The boiler will retain your settings during a power outage.

11.5 Resetting the Boiler

If an error message appears during boiler operation, reset the boiler to resolve the problem. Press the Back button (↶) on the front panel to reset the boiler.

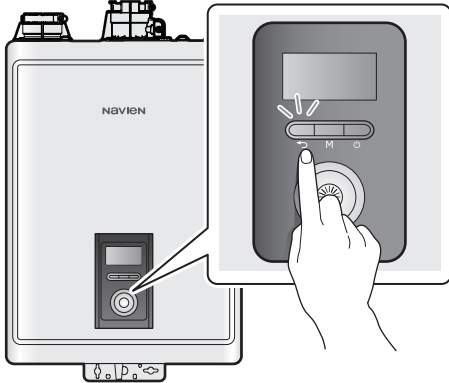

If resetting the boiler does not solve the problem, refer to the Troubleshooting section of this manual or contact Technical Support at 1-800-519-8794.

11.6 Accessing Basic Menu Items

In the Menu Select screen, you can view the boiler's operating conditions, configure the space heating and DHW temperatures, and review error history. Press the Menu button (M) to enter the Main Menu screen.

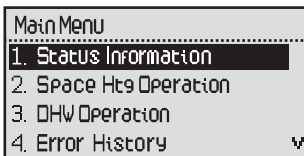

11.7 Viewing Basic Information

To view information about the boiler, press the Menu button (M), and then select "1. Status Information".

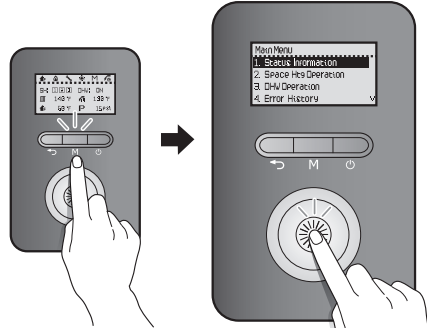

Rotate the Command dial (⊙) to switch between the information items. Press the Command dial (⊙) to select an item and view the information.

Press the Back button (↶) to exit information view mode.

Item	Description
1. Operation State	Current Operation State
2. Heat Capacity	Heat Capacity (%)
3. SH Set Temp	Space heating set temperature (°F)
4. DHW Set Temp	DHW indirect supply set temperature (°F)
5. AHU SH Set Temp	AHU Space Heating Set Temperature (°F) <ul style="list-style-type: none"> If AHU is not connected, "--" will be displayed. The temperature is displayed by 1 degree increments for Fahrenheit and by 0.5 degree increments for Celsius. This is due to the degree control specifications of 0.5 degree for the AHU communication type.
<p>Note Use with iFlow Air Handlers Only.</p>	
6. Supply Temp	Heating supply temperature (°F)
7. Return Temp	Boiler return temperature (°F)

Item	Description
8. Sys Supply Temp	System supply temperature (°F)
9. Sys Return Temp	System return temperature (°F)
10. Outdoor Temp	Outdoor temperature (°F)
11. Approx. Boiler Flow	Flow rate (GPM)
12. DHW Tank set Temp	DHW Tank set temperature (°F)
13. Tank Sensor Temp	DHW indirect tank temperature (°F)
14. Water Press	Water pressure (psi)
15. Flame Value	Flame detector AD value <ul style="list-style-type: none"> Flame On: 8bit AD values equal to or lower than 70 Flame Off: 8bit AD values equal to or higher than 175
16. Fan Target RPM	Set fan speed (RPM)
17. Fan Current RPM	Fan speed (RPM)
18. Fan Target APS	Set APS voltage (V)
19. Fan Current APS	APS voltage (V)
20. Exhaust Temp	Exhaust temperature (°F)
21. Outdoor Reset	Outdoor reset status (Enable / Disable)
22. Outdoor Reset Curve	Outdoor reset curve load type (displayed when the outdoor reset option "21. Outdoor Reset" is enabled) <ol style="list-style-type: none"> Finned Tube Baseboard FAN Coil Cast Iron Baseboard Low Mass Radiant High Mass Radiant Radiator Custom (set by installer)
23. Boost Interval Time	Boost interval set time (min)

Item	Description
24. High Altitude	Sea Level (0–2,000 ft)
	Level 1 (2,000–5,400 ft)
	Level 2 (5,400–7,700 ft)
	Level 3 (7,700–10,100 ft)
25. Model	Model type
26. Gas	Fuel type (NG/LPG)
27. Main F/W Ver	Firmware version of the main controller
28. Panel F/W Ver	Firmware version of the panel controller

11.8 Setting the Space Heating Operation

To set the boiler's space heating operation, press the Menu button (M), and then select "2. Space Htg Operation".

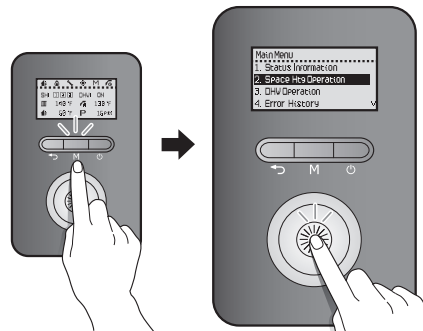

Rotate the Command dial (⊙) to switch between the list items or to increase/decrease setting values. Press the Command dial (⊙) to select an item or to confirm after making changes.

Press the Back button (↶) to return to the previous screen or menu.

Item	Description
1. SH Set Temp	<p>Set space heating target temperature (°F).</p> <ul style="list-style-type: none"> • Default: 180°F (82°C) • The setting range varies depending on the heating control type: <ul style="list-style-type: none"> - Supply Temperature or Sys Supply Temperature: 104–180°F (40–82°C) - Return Temperature or Sys Return Temperature: 86–149°F (30–65°C) <p>Note</p> <ul style="list-style-type: none"> • If “3. Zone Priority Settings” is enabled, the set temperature for each zone is displayed on the screen. • After selecting and confirming the set temperature for each zone, press and hold the Command dial  for more than 2 seconds to return to normal operation mode.
2. Zone Settings	<p>Set the system type and operation details.</p> <ol style="list-style-type: none"> 1. Zone Pump System 2. Zone Valve System
2-1. Pump 1 Settings	<p>Set the pump 1 type.</p> <ol style="list-style-type: none"> 1. Zone 1 pump 2. DHW pump <p>This operation is available only when “2. Zone Settings” is Zone Pump System.</p>

Item	Description
3. Zone Priority Settings	<p>Set the zone priority.</p> <ul style="list-style-type: none"> • Setting range: Enable / Disable • Default: Disable <p>If “3. Zone Priority Settings” is enabled, the default zone priorities are set as follows.</p> <ul style="list-style-type: none"> • When “2-1. Pump 1 Settings” is set to “Zone 1 Pump”: <ul style="list-style-type: none"> - Priority 1: Zone 1 - Priority 2: Zone 2 - Priority 3: Zone 3 • When “2-1. Pump 1 Settings” is set to “DHW Pump”: <ul style="list-style-type: none"> - Priority 1: Zone 2 - Priority 2: Zone 3 - Priority 3: -- (None: DHW Pump) <p>Note</p> <ul style="list-style-type: none"> • The number of priorities for the zones differs depending on the set pump 1 type (2-1. Pump 1 Settings). • If you change the pump 1 type (2-1. Pump 1 Settings), the set priorities will be initialized. • If you change the zone settings (2. Zone Settings), the set priorities will be initialized. • If “5. Navien zone cont.” is enabled, “3. Zone Priority Settings” will be disabled and you cannot set the zone priority. • If “21. Outdoor Reset” is enabled, “3. Zone Priority Settings” will be disabled.
4. Outdoor Reset ON/OFF	<p>Enable or disable the Outdoor Reset Control feature (Default: Enabled).</p>

Item	Description
4-1. Outdoor Reset Curves	Select a heatload type for the Outdoor Reset Control. 1: Finned Tube Baseboard 2: FAN Coil 3: Cast Iron Baseboard 4: Low Mass Radiant 5: High Mass Radiant 6: Radiator 7: Custom (set by installer)
4-2. Outdoor High Temp Set	Set the maximum temperature for the Outdoor Reset Control. <ul style="list-style-type: none"> Setting range: [MIN Set-point + 9°F (5°C)] – 104°F (40°C) Default: 70°F (21°C)
4-3. Outdoor Low Temp Set*	Set the maximum temperature for the Outdoor Reset Control. <ul style="list-style-type: none"> Setting range: -4°F (-20°C) – [MAX Set-point – 9°F (5°C)] Default: 14°F (-10°C)
4-4. WWSD Temp	Set the Warm Weather Shut-down temperature. <ul style="list-style-type: none"> Setting range: OFF, 50°F (10°C) – 104°F (40°C) Default: OFF
4-5. WWSD On Diff	Set the differential temperature to deactivate the Warm Weather Shut-down. <ul style="list-style-type: none"> Setting range: 0°F (0°C) – 36°F (20°C) Default: 5°F (3°C)
4-6. Boost Interval Time	Set the boost interval time. <ul style="list-style-type: none"> Setting range: 0 – 120 min Default: 0 min
5. Navien zone cont.	Enable or disable heating zones utilizing the Navien Zone Controller. <ul style="list-style-type: none"> Setting range: Enabled/ Disabled Default: Disabled

Item	Description
6. SH Control Method	Select a heating control type. 1: Supply Temperature 2: Return Temperature 3: Sys Supply Temperature 4: Sys Return Temperature <ul style="list-style-type: none"> Default: Supply Temperature <div style="background-color: black; color: white; padding: 2px; border-radius: 5px; display: inline-block;">Note</div> This menu is not available when connecting the AHU communication type or cascade mode because heating is performed only by controlling the heating supply water.

* Available only when "4. Outdoor Reset ON/OFF" is set to "Enabled".

** A preset or user defined temperature range is set automatically based on the curve selected. Refer to the settings table for details.

Heat Load	Supply Set Point Range	Return Set Point Range	Remarks
1. Finned Tube Baseboard	120–180°F (48.5–82°C)	101–147°F (38–63.5°C)	Default
2. Fan Coil	140–180°F (60–82°C)	116–147°F (46.5–63.5°C)	
3. Cast Iron Baseboard	100–170°F (37.5–76.5°C)	86–139°F (30–59°C)	
4. Low Mass Radiant	80–140°F (26.5–60°C)	70–116°F (21–46.5°C)	
5. High Mass Radiant	80–120°F (26.5–48.5°C)	70–101°F (21–38°C)	
6. Radiators	120–170°F (48.5–76.5°C)	101–139°F (38–59°C)	
7. Custom	104–180°F (40–82°C)	86–149°F (30–65°C)	User-defined

Heat loads 1-6 show the preset temperature ranges based on the load type selected, while heat load 7 provides a custom temperature range. When the custom temperature range is in use, the boiler operates based on the user-defined "Absolute Min" and Absolute Max" temperature settings.

*** The boost interval time may be set to prevent interruption in space heating while using the Outdoor Reset Control mode, due to changes in heat load conditions. With the boost interval time enabled, the boiler increases the space heating supply temperature by 9°F (5°C) and the return temperature by 5°F (3°C) after a set time elapses.

Once the boost interval time expires or the heat load demand is satisfied, the boiler will then revert back to its normal space heating settings.

NOTICE

An outdoor sensor error may occur if the Outdoor Reset Control mode is enabled without the outdoor sensor installed

Note In the Outdoor Reset Control mode, the boiler's water temperature is regulated according to the outdoor temperature to maximize boiler efficiency and reduce energy usage. This mode must remain enabled and the outdoor sensor must be installed to comply with federal efficiency regulations. The Outdoor Reset mode may only be disabled if the boiler is not used for any space heating.

11.9 Setting the DHW Operation (Indirect)

To set the boiler's indirect DHW operation, press the Menu button (M), and then select "3. DHW Operation".

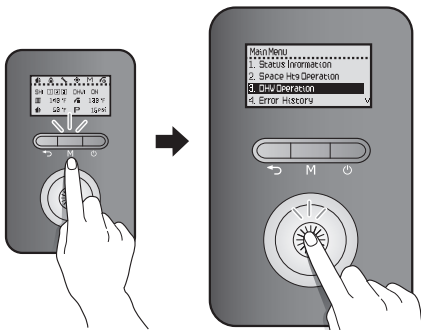

Rotate the Command dial (⊙) to switch between the list items or to increase/decrease setting values. Press the Command dial (⊙) to select an item or to confirm after making changes.

Press the Back button (⏪) to return to the previous screen or menu.

Item	Description
1. DHW Tank Set Temp	<p>Set the external hot water tank temperature (°F).</p> <ul style="list-style-type: none"> Setting range: 86–149°F (30–65°C) Default: 122°F (50°C) <p>This option is available only when a tank temperature sensor is connected to the boiler, and only when "3. DHW Call Signal" is set to "2. DHW Tank Sensor".</p>
2. DHW Boiler Set Temp	<p>Set DHW Thermostat Temperature.</p> <ul style="list-style-type: none"> Setting range: 104°F (40°C, Absolute MIN) - 180°F (82°C, Absolute MAX). Default: 180°F (82°C) <p>Set DHW Tank Sensor Temperature.</p> <ul style="list-style-type: none"> Setting range: [DHW Tank Set Temp + 18°F (10°C)] - 180°F (82°C, Absolute MAX) Default: 180°F (82°C)
3. DHW Call Signal	<p>Select a device for sensing the DHW demand.</p> <ol style="list-style-type: none"> DHW Thermostat DHW Tank Sensor <ul style="list-style-type: none"> Default: DHW Thermostat
4. DHW Priority Time*	<p>Set the DHW Priority time.</p> <ul style="list-style-type: none"> Setting range: 0 - 180 min Default: 30 min
5. Anti Legionella Function**	<p>Enable or disable the protection against legionella bacteria.</p> <ul style="list-style-type: none"> Setting range: Enable / Disable Default: Disable

Item	Description
6. DHW control method	Select a DHW control type. 1. Supply water 2. Sys Supply water • Default: Supply water

* DHW Priority Time refers to the time duration that the boiler will give priority to DHW over space heating.

**This function will provide protection from growth of legionella bacteria in the DHW tank only. It will not protect water supply piping.

A mixing valve must be installed on the DHW supply line when this mode is enabled as water temperatures will exceed 140°F (60°C).

⚠ CAUTION

When "5. Anti Legionella Function" is set to "Enable" and even if the DHW tank is set to less than 140°F (60°C), hot water 140°F (60°C) or higher may be discharged approximately once a week.

11.10 Viewing Error History

To view the error history, press the Menu button (M), and then select "4. Error History".

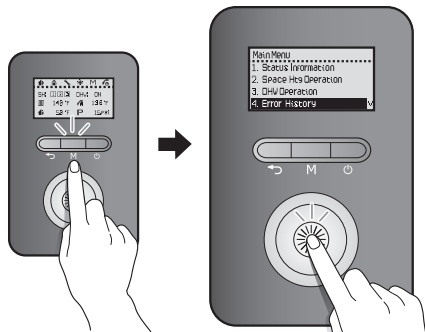

A list of 10 recent errors are displayed on the screen, with the most recent error displayed at the top of the list.

5. Error History	
1. Err 003-00	↖
2. Err 023-00	
3. Err 205-00	
4. Err 003-00	↘

Rotate the Command dial (⊙) to switch between the list of errors. Press the Command dial (⊙) to select an error to view detailed information.

4. Err 003-00	
Ignition failure	
Check gas SUPPLY	
2016-11-23	08:34:05

Press the Back button (⬅) to return to the previous screen or menu.

Note

- The front panel displays flashes in red and the error icon is displayed (flashing) when a level 1 error is detected. You can press the command dial to enter error display mode. Boiler operation is maintained during a level 1 error.
- A level 1 error is automatically cleared when the problem is resolved.
- You can press the Power button (⏻) to clear a level1 error. Then the error is cleared if the problem has been resolved.

11.11 Viewing Other System Information

To view the miscellaneous system information, press the Menu button (M), and then select "5. EMS Data".

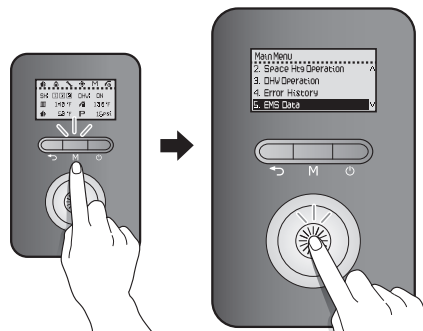

Rotate the Command dial (⊙) to switch between the information items. Press the Command dial (⊙) to select an item and view the information.

Press the Back button (↶) to return to the previous screen or menu.

Item	Description
1. SH Operation Time	View monthly space heating operation logs.
2. DHW Operation Time	View monthly DHW operation logs.
3. Gas Consumption	View monthly gas consumption.

11.12 Setting the Display Options

To set the front panel display options, press the Menu button (M), and then select "6. Configuration".

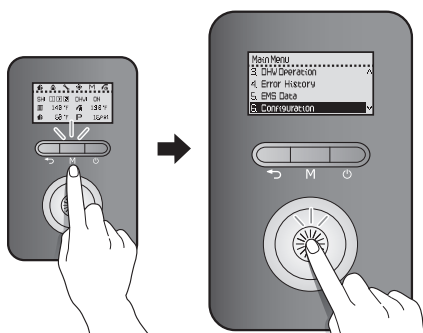

Rotate the Command dial (⦿) to switch between the list items or to increase/decrease setting values. Press the Command dial (⦿) to select an item or to confirm after making changes.

Press the Back button (↶) to return to the previous screen or menu.

Item	Description
1. Language	Select a display language. 1. English 2. French • Default: English
2. °C/°F Setting	Select a temperature unit. 1. Celsius (°C) 2. Fahrenheit (°F) • Default: Fahrenheit (°F)

Item	Description
3. PSI/BAR Setting	Select a water pressure unit. 1. PSI 2. BAR • Default : PSI
4. Time Setting	Set the system clock (RTC). • Display format: YYYY. MM.DD / HH:MM:SS
5. Backlight Time Setting	Set the Backlight On time. • Setting range: 0 – 60 sec • Default: 10 sec

11.13 Accessing Advanced Menu Items

11.13.1 Viewing Service Information

To view service information about the boiler, press the Back button (↶) and the Menu button (M) simultaneously for 3 seconds, and then select "1. Service Status Info".

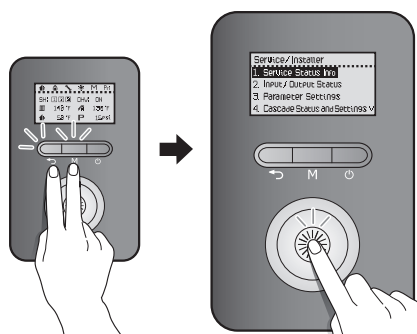

Rotate the Command dial (⦿) to switch between the information items. Press the Command dial (⦿) to select an item and view the information.

Press the Back button (↶) to return to the previous screen or menu.

Item	Description
1. Elapsed Time After Install	Elapsed time since installation
2. HEX Overheat - No. of Times	Number of times the heat exchanger overheat protection has activated
3. Flame Loss - No. of Times	Number of times a flame loss/misfire has occurred
4. 2nd ignition - No. of Times	Number of second ignition attempts
5. 3rd ignition - No. of Times	Number of third ignition attempts
6. 4th ignition - No. of Times	Number of fourth ignition attempts
7. 5 ~10th ignition - No. of Times	Number of tenth ignition attempts
8. ΔT Limit - No. of Times	Number of times supply return temperature limit control has activated.
9. Supply Limit - No. of Times	Number of times Recirculation supply temperature limit control has activated.
10. ΔT High - No. of Times	Number of times combustion stopped due to supply return temperature.

11.13.2 Viewing Input and Output Status

To view the boiler's input and output status, press the Back button (↶) and the Menu button (M) simultaneously for 3 seconds, and then select "2. Input/Output Status".

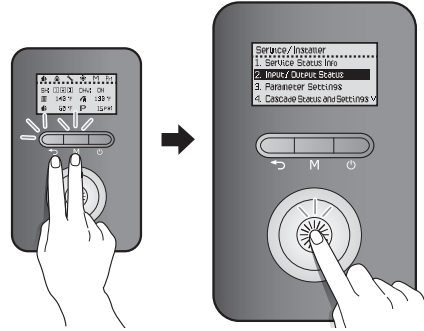

Rotate the Command dial (⌚) to switch between the information items. Press the Command dial (⌚) to select an item and view the information.

Press the Back button (↶) to return to the previous screen or menu.

Item	Description
1. SH1 Thermostat Status	Space heating thermostat 1 input status
2. SH2 Thermostat Status	Space heating thermostat 2 input status
3. SH3 Thermostat Status	Space heating thermostat 3 input status
4. DHW Thermostat Status	DHW thermostat 1 input status
5. Boiler Pump Status	Boiler pump output status
6. DHW/Zone1 Pump Status	DHW / Zone 1 pump output status
7. Zone2 Pump Status	Zone 2 pump output status
8. system/Zone3 Pump Status	System / Zone 3 pump output status
9. Zone V/V 1 Status	Zone 1 valve output status

Item	Description
10. Zone V/V 2 Status	Zone 2 valve output status
11. Zone V/V 3 Status	Zone 3 valve output status
12. HTL Input Status	HTL input status
13. Dual Venturi Status	Dual Venturi output status
14. LWCO Input Status	LWCO input status
15. Air Handler Interface Output Status	Air Handler Interface output status
16. DHW Priority Output Status	DHW priority output status

11.13.3 Setting the Operation Parameters

To set the boiler's operation parameters, press the Back button (↩) and the Menu button (M) simultaneously for 3 seconds, and then select "3. Parameter Settings".

CAUTION

Parameters must be set by a qualified professional with an extensive understanding of the boiler system. Setting parameters improperly may lead to property damage or injury.

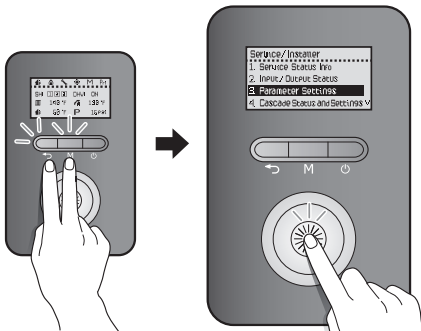

In the password screen, rotate the Command dial (⦿) to change numbers and places, and press the Command dial (⦿) to enter the password.

The factory default password is "1234".



After entering the parameter setting screen, rotate the Command dial (⦿) to switch between the parameters or to increase/decrease setting values. Press the Command dial (⦿) to select a parameter or to confirm after making changes.

Press the Back button (↩) to return to the previous screen or menu.

Item	Description
1. Supply MIN Set-point	Set the space heating supply minimum temperature. <ul style="list-style-type: none"> Setting range: 77°F (25°C) – [MAX Set-point – 36°F (20°C)] Default: 104°F (40°C)
2. Supply MAX Set-point	Set the space heating supply maximum temperature. <ul style="list-style-type: none"> Setting range: [Supply MIN Set-point + 36°F (20°C)] – 185°F (85°C) (When used with NHB-H boilers) Default: 180°F (82°C)
3. Return MIN Set-point	Set the space heating return minimum temperature. <ul style="list-style-type: none"> Setting range: 68°F (20°C) – [MAX Set-point – 18°F (10°C)] Default: 86°F (30°C)
4. Return MAX Set-point	Set the space heating return maximum temperature. <ul style="list-style-type: none"> Setting range: [MIN Set-point + 18°F (10°C)] – 158°F (70°C) Default: 149°F (65°C)

Item	Description
5. SH Burner Off Diff	<p>Set the temperature range to turn off space heating.</p> <ul style="list-style-type: none"> Setting range: - 2°F (1°C) – 54°F (30°C) Default: 4°F (2°C)
6. SH Burner On Diff	<p>Set the temperature range to turn on space heating.</p> <ul style="list-style-type: none"> Setting range: - 2°F (1°C) – 54°F (30°C) Default: 5°F (3°C)
7. SH Min Limit	<p>Set space heating minimum heat capacity limit.</p> <ul style="list-style-type: none"> Setting range: Space heating Min capacity (%) – [space heating min capacity limit -20]) % Default: Boiler's minimum heat capacity
8. SH Max Limit	<p>Set space heating maximum heat capacity limit.</p> <ul style="list-style-type: none"> Setting range: (Space heating Min capacity limit +20) % – 100% Default: 100%
9. SH Min Burning Time	<p>Set the low-load combustion time at initial operation.</p> <ul style="list-style-type: none"> Setting range: 1 – 20 min Default: 1 min
10. Burning Acceleration Time	<p>Set the time to reach the maximum space heating capacity after initial operation.</p> <ul style="list-style-type: none"> Setting range: 0 – 20 min Default: 1 min

Item	Description
11. Zone T/S Start-up Delay Time	<p>Set the delay time for the burner to operate after a call for heat is received for the AHU.</p> <ul style="list-style-type: none"> Setting range: 0–120 sec Default: 0 min
12. Anti Fast Cycling Time*	<p>Set the anti-fast cycling time.</p> <ul style="list-style-type: none"> Setting range: 0 – 20 min Default: 3 min
13. DHW Min Limit	<p>Set the DHW minimum heat capacity.</p> <ul style="list-style-type: none"> Setting range: DHW minimum capacity (%) – [DHW MAX capacity limit - 20] % Default: Boiler's minimum heat capacity
14. DHW Max Limit	<p>Set the DHW maximum heat capacity.</p> <ul style="list-style-type: none"> Setting range: [DHW Min capacity limit + 20] % – 100% Default: 100%
15. Freeze protection	<p>Set the pump freeze protection temperature.</p> <ul style="list-style-type: none"> Setting range: 43°F (6°C) – 50°F (10°C) Default: 50°F (10°C) <p>Note The boiler pump will operate to provide system freeze protection when the water temperature falls below this value.</p>
16. Low Sys Pressure	<p>Set the low water system pressure.</p> <ul style="list-style-type: none"> Setting range: 4 – 17 psi Default: 6 psi
17. Boiler pump Oper(DHW)	<p>Turn on or turn off the boiler pump in DHW mode.</p> <ul style="list-style-type: none"> Setting range: On/Off Default: Off

Item	Description
18. Sys pump Oper(DHW)	Turn on or turn off the system pump in DHW mode. <ul style="list-style-type: none"> Setting range: On/Off Default: Off
19. Zone2 pump Oper(DHW)	Turn on or turn off Zone 2 pump in DHW mode. <ul style="list-style-type: none"> Setting range: On/Off Default: Off
20. DHW pump Oper(DHW pri)	Turn on or turn off the DHW pump in DHW mode when both the space heating and DHW demands are present. <ul style="list-style-type: none"> Setting range: On/Off Default: On
21. Boiler Pump Delay**	Set the space heating pump over-run time. <ul style="list-style-type: none"> Setting range: 3 – 40 min Default: 40 min
22. DHW Demand On Diff	When the DHW temperature sensor is used: <ul style="list-style-type: none"> Setting range: 0–10°C (0–18°F) Default: 3°C (5°F)
23. DHW Demand Off Diff	When the DHW temperature sensor is used: <ul style="list-style-type: none"> Setting range: 0–5°C (0–9°F) Default: 0°C (0°F)
24. HEX Protection Level	Set the heat exchanger's protection level. <ul style="list-style-type: none"> Setting range: 0–4 Level Default: 4 Level <p>Note The HEX Protection Level Settings only applies to the NHB-H boilers.</p>

Item	Description
25. Service Notif Time	Set the time for service notification. <ul style="list-style-type: none"> Setting range: 30 – 3650 days (10 years) It can be set in 10 day increments. Default: 1820 days (5 years)
26. Service Notif Cycl	Set the service notification according to the operating times. <ul style="list-style-type: none"> Setting range: 300 – 36500 cycles It can be set in 100 cycle increments. Default: 18200 cycles
27. Service contact #	View the service contact information.
28. Factory Reset	Initialize all parameter settings (panel and main controller) to factory default.
29. P/W Change	Change the parameter setting password. Rotate the Command dial (⊙) to change numbers and places, and press the Command dial (⊙) to save the new password.

Note

- If you enter an incorrect password 10 times or make no inputs 5 minutes, the boiler will return to Normal mode.
- To return to the previous mode, press the Reset button.
- The Factory default password is "1234".
- If you make no inputs for 10 seconds in the Parameter Edit mode, the current parameter value will be saved automatically.
- Press and hold the Back button (↶) in Parameter Edit mode for 5 seconds to reset individual parameters to their default values.
- When you reset one of the following parameters, the corresponding parameter will be reset automatically:
 - Supply Min or Max capacity limit
 - Return Min or Max capacity limit

* The anti-fast cycling time is the duration that the boiler stops its space heating operation when the space heating supply or return temperatures reach the set values for boiler operation stop temperatures. The boiler will not resume space heating until the duration elapses, even when the space heating supply or return temperatures return to within the set ranges.

**Boiler Pump Delay is the duration the circulation pump continues to run between the space heating supply or return temperature reaching the set point and the burner turning off. If the space heating supply or return temperature remains outside of the boiler operation temperature range for a set period, the pump stops for 10 mins, runs again for 5 mins, and then repeats the cycle.

11.13.4 Configuring a Cascade System

To view and configure the cascade settings, press the Back button (↶) and the Menu button (M) simultaneously for 3 seconds, and then select "4. Cascade Status and Settings".

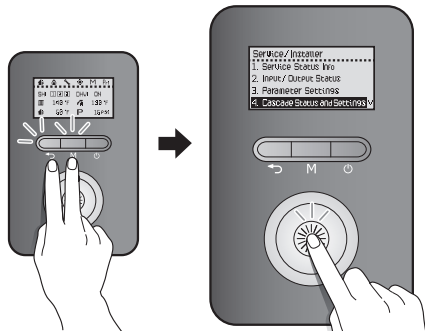

Rotate the Command dial (⊙) to switch between the parameters or to increase/decrease setting values. Press the Command dial (⊙) to select a parameter or to confirm after making changes.

Press the Back button (↶) to return to the previous screen or menu.

Item	Description
<p>1. Cascade System Setting (For NHB-110/150H models only)</p>	<ul style="list-style-type: none"> • To enter the Cascade Main setting mode, select Start. • The setting mode is entered and the IDs of all boilers that can communicate with the Main via the RS485 communication line are initialized. • The boilers whose IDs are initialized by the Main are set to <Sub setting mode>, if you press the OK button for 2 seconds or more, the Main gives you the ID and it is displayed on the screen. • The Main periodically checks the RS485 communication, and when there is an ID request from the Sub, the ID is sequentially incremented and added to the Sub (1 to 16). • Select OK in the Main to complete the cascade setting, and the Main and the assigned Sub IDs will return to <Normal operation mode> and turn into CASCADE ON state. At this time, the Main icon on the Main panel lights up. • If the cascade setting is idle for more than 1 hour, it returns to <Normal operation mode> and reverts to CASCADE OFF state automatically.

Item	Description
2. Cascade System Removal	<p>Select this option on the Main unit of a cascade system to end cascade operation.</p> <ul style="list-style-type: none"> Enter Cascade system setting mode to reassign IDs and begin a cascade system again. If a Sub unit has a network communication problem, select this option on the Sub unit to exclude the individual unit from the cascade system.
3. Cascade Init-operation Unit	<p>Set the initial number of activated boilers.</p> <ul style="list-style-type: none"> Setting range: 0 – 16 Default: 0 <p>Note Sub units of a cascade system cannot use this item.</p>
4. Cascade ON HC Offset	<p>Adjust the staging of boilers to be added to the system load.</p> <ul style="list-style-type: none"> Setting range: - 20% – +20% (60 – 100% load) Default: 0 (80% load) <p>Note Sub units of a cascade system cannot use this item.</p>
5. Cascade OFF HC Offset	<p>Adjust the staging of boilers to be removed from the system load.</p> <ul style="list-style-type: none"> Setting range: - 10% – +10% (20 – 40% load) Default: 0 (30% load) <p>Note Sub units of a cascade system cannot use this item.</p>

Item	Description
6. Number of Oper-Unit	The number of units currently operating in the cascade system.
7. Cascade Info.	View the operating status of individual units in the cascade system.
8. Vent Type Setting	<p>If not in the cascade system, the default setting is Individual Vent.</p> <p>Note In the cascade system, the default setting is Common Vent.</p>
9. Cascade Min-Operation Unit	<p>Set the minimum number of the operation units for the cascade system.</p> <ul style="list-style-type: none"> Setting range: 1 – 16 Default: 1 <p>Note Sub units of a cascade system cannot use this item.</p>

11.13.5 Setting the External Connection

To view and configure the external network connection, press the Back button (↩) and the Menu button (M) simultaneously for 3 seconds, and then select "5. External Connection".

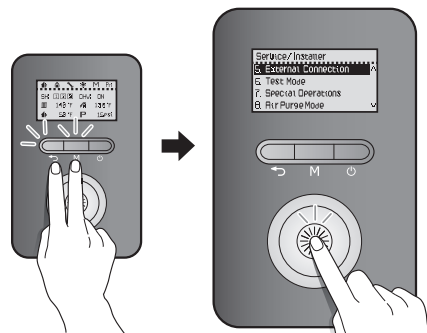

Rotate the Command dial (⊙) to switch between the parameters or to increase/decrease setting values. Press the Command dial (⊙) to select a parameter or to confirm after making changes.

Press the Back button (↶) to return to the previous screen or menu.

Item	Description
1. NaviLink Connect	Turn on or turn off the remote control capabilities via the NaviLink connection. <ul style="list-style-type: none"> • Setting range: Enable or Disable • Default: Disable
2. AHU Communication	AHU connect is communication feature can be used when NHB-H. AHU has an RS-485 communication function. <ul style="list-style-type: none"> • Setting range: Enable or Disable • Default: Disable

Note The AHU connection is compatible with iFlow Air Handlers only. Contact iFlow directly for more information.

11.13.6 Diagnosing the Boiler System

To run a series of test procedures for a system diagnosis, press the Back button (↶) and the Menu button (M) simultaneously for 3 seconds, and then select "6. Test Mode".

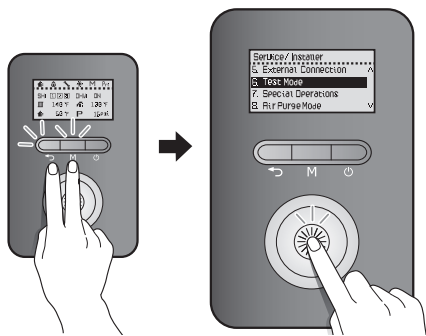

Rotate the Command dial (⦿) to switch between the test procedures. Press the Command dial (⦿) to run a test procedure.

Press the Back button (↶) to return to the previous screen or menu.

Item	Description
1. Fan Motor	Test the fan operation by manually changing the fan speed. <ul style="list-style-type: none"> • From a stopped state, the fan speed gradually increases and reaches the top speed, and then the fan speed decreases until the fan stops operating. • Rotate the Command dial (⦿) to run or stop the fan test.
2. Boiler Pump	Test the boiler pump operation. <ul style="list-style-type: none"> • The boiler pump is turned on as soon as you enter the test mode. • Press the Command dial (⦿) to toggle the pump operation (On -> Off / Off -> On).
3. System (zone3) Pump	Test the system (zone 3) pump operation. <ul style="list-style-type: none"> • The system (zone 3) pump is turned on as soon as you enter the test mode. • Press the Command dial (⦿) to toggle the pump operation (On -> Off / Off -> On).
4. Zone2 Pump	Test the zone 2 pump operation. <ul style="list-style-type: none"> • The zone 2 pump is turned on as soon as you enter the test mode. • Press the Command dial (⦿) to toggle the pump operation (On -> Off / Off -> On). • This option is available only when the "Zone Pump System" is active.

Item	Description
5. DHW (zone 1) Pump	<p>Test the DHW (zone 1) pump operation.</p> <ul style="list-style-type: none"> The DHW (zone 1) pump is turned on as soon as you enter the test mode. Press the Command dial (⊗) to toggle the pump operation (On -> Off / Off -> On).
6. Zone1 Valve Output	<p>Test the zone 1 valve operation.</p> <ul style="list-style-type: none"> The zone 1 valve is turned on as soon as you enter the test mode. Press the Command dial (⊗) to toggle the valve operation (On -> Off / Off -> On). This option is available only when the "Zone Valve System" is active.
7. Zone2 Valve Output	<p>Test the zone 2 valve operation.</p> <ul style="list-style-type: none"> The zone 2 valve is turned on as soon as you enter the test mode. Press the Command dial (⊗) to toggle the valve operation (On -> Off / Off -> On). This option is available only when the "Zone Valve System" is active.

Item	Description
8. Zone3 Valve Output	<p>Test the zone 3 valve operation.</p> <ul style="list-style-type: none"> The zone 3 valve is turned on as soon as you enter the test mode. Press the Command dial (⊗) to toggle the valve operation (On -> Off / Off -> On). This option is available only when the "Zone Valve System" is active.
9. Dual Venturi	<p>Test the dual venturi operation.</p> <ul style="list-style-type: none"> The dual venturi is turned on as soon as you enter the test mode. Press the Command dial (⊗) to toggle the dual venturi operation (On -> Off / Off -> On).

11.13.7 Setting the Special Operation Modes

To operate the boiler in special operation modes, press the Back button (↩) and the Menu button (M) simultaneously for 3 seconds, and then select "7. Special Operations".

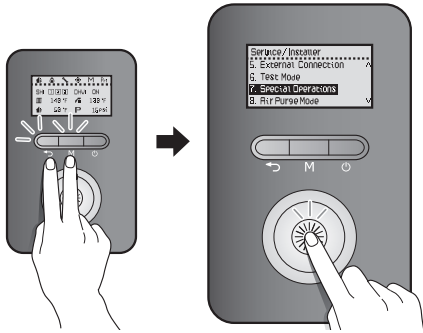

Rotate the Command dial (⊙) to switch between the operation modes. Press the Command dial (⊙) to select an operation mode.

The boiler resumes operation in normal operation mode if no input is detected for 3 hours.

Press the Back button (↩) to return to the previous screen or menu.

Item	Description
1. Normal	Set the boiler to run in Normal operation mode.
2. 1st MIN	Set the boiler to run in 1st stage minimum operation mode.
3. 1st MAX	Set the boiler to run in 1st stage maximum operation mode.
4. 2nd MIN	Set the boiler to run in 2nd stage minimum operation mode.
5. 2nd MAX	Set the boiler to run in 2nd stage maximum operation mode.

11.13.8 Operating in Air Purge Mode

To operate the boiler in air purge mode, press the Back button (↩) and the Menu button (M) simultaneously for 3 seconds, and then select "8. Air Purge Mode".

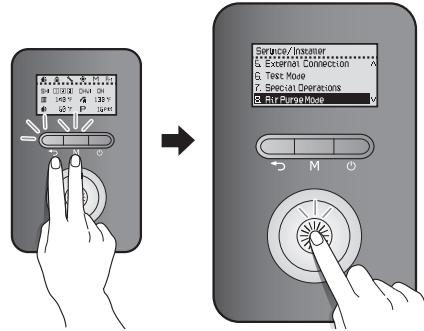

Rotate the Command dial (⊙) to switch between the parameters. Press the Command dial (⊙) to run an air purge.

The boiler resumes operation in normal operation mode if no input is detected for 15 minutes.

Press the Back button (↩) to return to the previous screen or menu.

Item	Description
1. SH pipe air purge	Run an air purge on the space heating pipe.
2. DHW pipe air purge	Run an air purge on the DHW pipe.

11.14 Understanding Error Codes

When an error code appears on the front panel, refer to the following chart for a definition and possible remedy for the situation.

Error Code	Reason	Self-diagnostic/Action
E001	Heat Exchanger Overheat	Check for proper system flow.
E003	Ignition Failure	Check gas supply valve and igniter.
E004	False Flame	Check electric ground.
E012	Flame Loss	Check gas, venting and condensate trap.
E016	Heat Exchanger Overheat	Check flow, clean system filters.
E030	Exhaust Overheat	Check flow, clean system filters.
E046	Heat Exchanger Thermistor	Check thermistor connector.
E047	Exhaust Thermistor	Check thermistor connector.
E060	Abnormal Dual Venturi	Check dual venturi.
E109	Abnormal Fan Motor	Check fan and venting.
E110	Exhaust Blockage	Check exhaust venting.
E205	Heating Supply Temp.Sensor	Check flow, thermistor connector.
E218	Heating Return Temp.Sensor	Check thermistor connector.
E278	Ext. Supply Sensor Not Detected	Check sensor connections.
E279	Ext. Return Sensor Not Detected	Check sensor connections.
E291	Return Temp. Exceeds Supply	Check for reversed piping.
E302	Low Water Pressure	Check water pressure.
E352	High Water Pressure	Check water pressure.
E353	Water Pressure Sensor	Check WPS.
E480	DHW Tank Sensor Not Detected	Check sensor connections.
E515	Abnormal PCB	Check PCB connections.
E517	Abnormal DIP Switch	Check DIP switch settings.
E594	Abnormal EEPROM	Check the PCB.
E615	Abnormal Memory	Check PCB connections.
E736	Cascade Communication	Check cascade cable.
E740	Outdoor Sensor Not Detected	Check sensor connections.
E762	Vent Pipe Not Fully Inserted	Insert pipe 2- ³ / ₄ " (70 mm) into exhaust collar.
E777	Low Water Cutoff Activated	Check supply water.
E782	Front Panel Communication	Check panel connections.
E784	Zone Controller Communication	Check wiring and settings.
E786	Improper Front Panel Detected	Check for correct panel version.
E788	Incorrect Gas Type Setting	Check DIP switch setting.

If any of these remedies do not resolve the problem, contact Technical Support at 1-800-519-8794.

12. Appendixes

12.1 Gas & High Altitude Conversion

This boiler is configured for Natural Gas at the factory.

- If conversion to Propane Gas is required by the boiler, use the PROPANE GAS & HIGH ALTITUDE CONVERSION KIT supplied with the boiler.
- If the boiler is installed at a high altitude (above 5,400 ft) for NG, use the NATURAL GAS HIGH ALTITUDE CONVERSION KIT supplied with the boiler.

Note For Propane gas high altitude conversion, use the PROPANE GAS & HIGH ALTITUDE CONVERSION KIT. Note that the Gas Orifice from the PROPANE GAS & HIGH ALTITUDE CONVERSION KIT covers the boiler's installation at an altitude of 0 to 10,100 ft.

⚠ DANGER

DO NOT perform a gas & High Altitude conversion without an officially approved conversion kit and the instructions supplied by Navien. Gas & High Altitude conversion using any other parts will result in extremely dangerous burner operation, leading to fire, explosion, severe personal injury or death.

Note The Natural Gas High Altitude Conversion Kit and Propane Gas & High Altitude Conversion Kit are attached to the inside of Product's case.

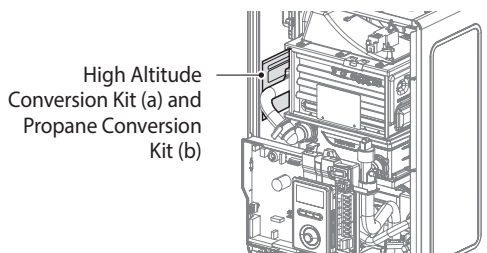

a. High Altitude Conversion Kit b. Propane Conversion Kit

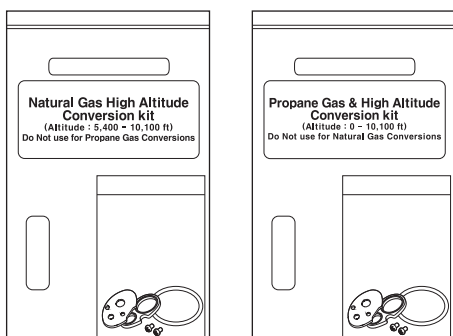

⚠ WARNING

Fire and Explosion Hazard

To prevent serious injury or death:

- ONLY a qualified installer, service agency, or the gas supplier* is required to install a conversion kit in accordance with Navien's instructions and all applicable codes and requirements of the authority having jurisdiction.
- The qualified installer, service agency, or the gas supplier* is responsible for the proper installation of this kit. The installation is not proper and complete until the operation of the converted appliance is checked as specified in the manufacturer's instructions supplied with the kit.

BEFORE starting the gas conversion:

- ALWAYS turn off electrical power supply to the boiler and close the manual gas shut-off valve.
- ALLOW the boiler to cool if it has been operating.
- For propane boilers: The propane supplier mixes an odorant with the propane to make its presence detectable. In some instances the odorant can fade, and the gas may no longer have an odor. Before startup (and periodically thereafter), have the propane supplier verify the correct odorant level in the gas.

* A qualified installer, service agency, or the gas supplier is any individual, firm, corporation or company which either in person or through a representative is engaged in and is responsible for the connection, utilization, repair or servicing of gas utilization equipment or accessories; who is experienced in such work, familiar with all precautions required, and has complied with all of the requirements of the authority having jurisdiction.

In Canada: The conversion shall be carried out in accordance with the requirements of the provincial authorities having jurisdiction and in accordance with the requirements of the CAN-B149.1 and CAN1-B149.2 Installation Code.

Tools Required:

- Phillips Screwdriver
- Flathead Screwdriver
- 5/32 in or 4 mm Allen Wrench
- Combustion Analyzer or Dual Port Manometer
- Gas Leak Detector

Included Items:

- Gas Orifice (Table 1)
- Gas Pressure and Conversion Kit Number Labels

NHB-055/080H Orifice Identification

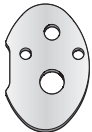
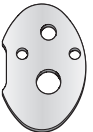
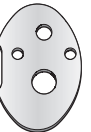
Gas Type	NG		LP
Altitude	0-5,399 ft	5,400-10,100 ft	0-10,100 ft
Orifice	 Factory Installed	 For High altitude	 For LP
Orifice Size	4.10/4.15	4.30/4.40	3.40/3.50
Kit No.	-	NAC-NH055/080	NAC-L055/080

NHB-110H Orifice Identification

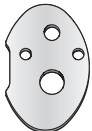
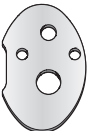
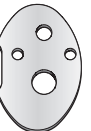
Gas Type	NG		LP
Altitude	0-5,399 ft	5,400-10,100 ft	0-10,100 ft
Orifice	 Factory Installed	 For High altitude	 For LP
Orifice Size	4.35/5.20	4.60/5.50	3.65/4.30
Kit No.	-	NAC-NH110	NAC-L110

NHB-150H Orifice Identification

Gas Type	NG		LP
Altitude	0-5,399 ft	5,400-10,100 ft	0-10,100 ft
Orifice	 Factory Installed	 For High altitude	 For LP
Orifice Size	4.45/6.25	4.70/6.60	3.65/5.05
Kit No.	-	NAC-NH150	NAC-L150

Table 1. Orifice Size

Note

Please confirm the installation elevation by using the provided QR code to access the following website (<https://www.navienc.com/elevation>) and entering the proper zip/postal code.

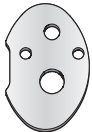
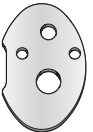
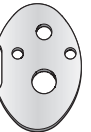
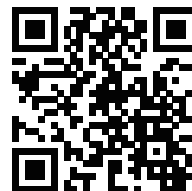

WARNING

Fire and Explosion Hazard

To prevent serious injury or death:

- Be careful not to confuse the PROPANE GAS & HIGH ALTITUDE CONVERSION KIT. Do NOT use the NATURAL GAS HIGH ALTITUDE CONVERSION KIT for NG when converting to PROPANE gas.
- Make sure that the conversion is completed with the proper orifice. If the installed orifice does not conform to the specifications in Table 1, incomplete combustion may occur, resulting in personal injury or property damage.

Procedure:

Note The procedure below can be applied to both Propane conversion and High Altitude conversion. Distinguish the kit supplied with the boiler before installing.

1. Turn off the power, gas, and water supply to the boiler.
2. Unfasten the 4 latches (2 at the top and 2 at the bottom) to remove the front cover and gain access to the internal components. See Figure 1 for illustration of the front cover clamps.

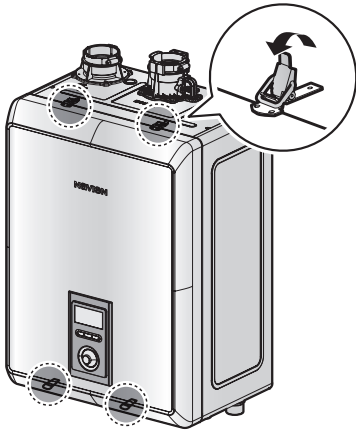
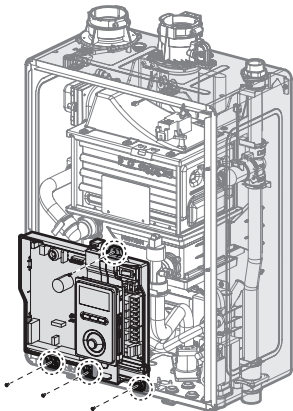
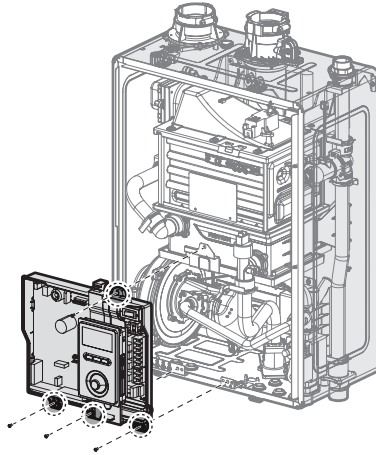

Figure 1. NHB-H Series Front cover

3. Remove the front cover and place it in a safe location to prevent accidental damage.
4. Label all the wires on the PCB.
5. Disconnect all the wires.
6. Loosen the four screws indicated in the figure.



7. Remove the PCB assembly.



8. With the internal components exposed, locate the gas inlet pipe and the gas valve in the middle of the unit, as shown in Figure 2.

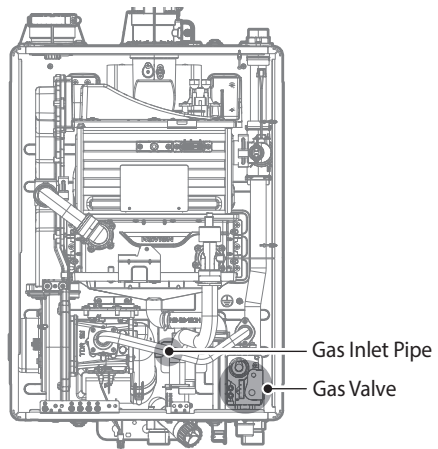

Figure 2. NHB-H Series Internal Components

9. Use a Phillips screwdriver to remove the two screws at location A - the connection below the gas valve where it connects to the pipe. See Figure 3 for reference. Once the screws are removed, carefully separate the pipe from the gas valve.

10. Once the gas inlet pipe is detached from the gas valve, find location B - the connection above the gas valve where it is attached to the fan motor assembly. Carefully remove the four screws by hand using a Phillips screwdriver and pull the gas valve away from the fan assembly to access the gas orifice.

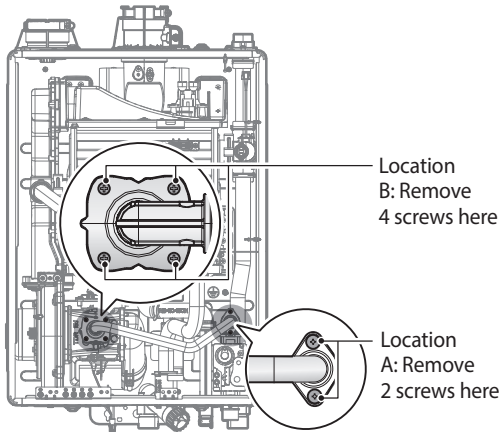

Figure 3. Detaching Gas Valve from Gas Inlet Pipe and Fan Motor Assembly

11. Once the Gas Orifice is exposed, remove the two screws that hold the part in place. Remove the Gas Orifice from its housing and prepare the new Gas Orifice for the LP conversion for installation.

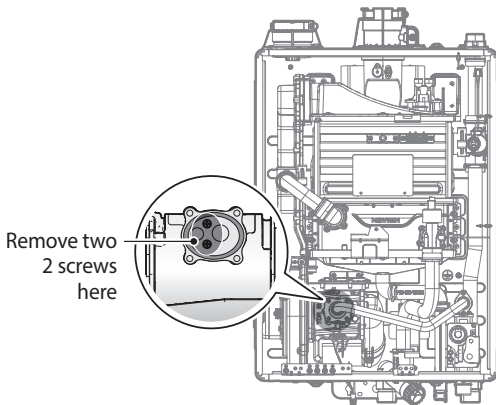

Figure 4. Access to Gas Orifice in Fan Assembly

! WARNING

Fire and Explosion Hazard

To prevent serious injury or death:

- DO NOT adjust or attempt to measure gas valve outlet pressure. The gas valve is factory-set for the correct outlet pressure. This setting is suitable for natural gas and propane, requiring no field adjustment.
- Attempting to alter or measure the gas valve outlet pressure could result in damage to the valve, causing potential severe personal injury, death or substantial property damage. Navien NHB-H boilers are shipped ready to fire natural gas ONLY.

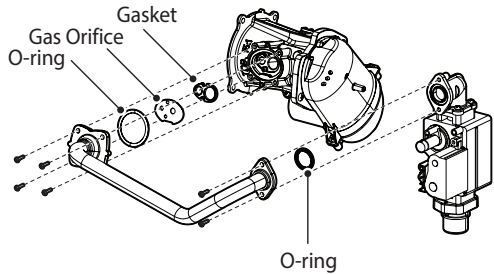

Figure 5. Exploded View of Gas Pipe Assembly

! DANGER

Fire and Explosion Hazard

To prevent serious injury or death:

- ALWAYS inspect the O-ring between the gas valve and gas valve inlet adapter whenever they are disassembled (see Figure 5).
- The O-ring must be in good condition and must be installed. Replace O-ring if needed.

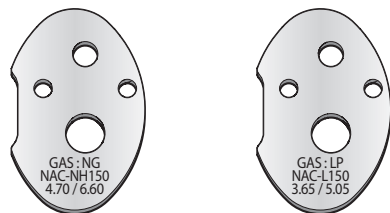
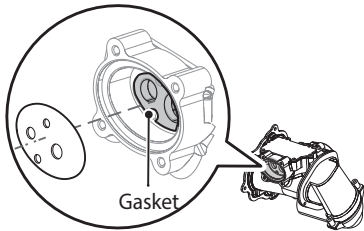

Figure 6. Orifice Identification

- Remove the Gas Orifice, ensure that the gasket is properly seated inside the port, and then install the new Gas Orifice for use with Propane gas. Ensure that the Orifice is properly seated on the gasket inside the port before proceeding to the next step.



- Replace the gas inlet pipe to its original position and use all screws to secure all connections.

Note Do not overtighten as this may damage or crack the components.

- Set the PCB DIP switch to change the gas type.
For LP, set DIP SW2 (Set of 8 Switches) #1 to ON.
For NG, set DIP SW2 (Set of 8 Switches) #1 to OFF.

⚠ WARNING

Ensure that you have turned off the power to the boiler before accessing the DIP switches.

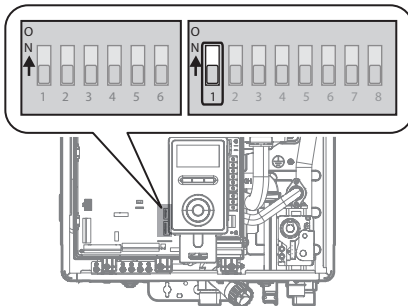

Switch	Function	Setting	Comment
1	Gas Type	Natural Gas	1-OFF
		Propane Gas	1-ON
2&3	High Altitude	0-1,999 ft (0-609m)	2-OFF, 3-OFF
		2,000-5,399 ft (610-1,645m)	2-ON, 3-OFF
		5,400-7,699 ft (1,646-2,346m)	2-OFF, 3-ON
		7,700-10,100 ft (2,347-3,078m)	2-ON, 3-ON
			Refer to Table 1 on page 121.

When applying the Gas Orifice for high altitude, set the PCB DIP switches by altitude according to the table above.

Note

- Please confirm the installation elevation by using the provided QR code to access the following website (<https://www.navieninc.com/elevation>) and entering the proper zip/postal code.

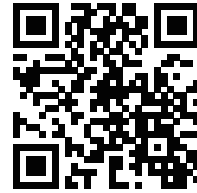

Note

- This unit may be installed at elevations up to 10,100 ft (3,078 m) for use with natural gas and propane. To use the unit at a specific altitude, the DIP switches should be set as described above.
- High Altitude: Above 2,000 ft (610 m), the unit will de-rate by 3% for each 1,000 ft (305 m) of altitude gain for NG and 4% de-rate for propane gas.
- For Natural Gas, if you install the unit at above 5,400 ft (1,646 m), it is required to change the Gas Orifice for high altitude. Be careful not to confuse it with the Gas Orifice for Propane.
- Note that the Gas Orifice from the PROPANE GAS & HIGH ALTITUDE CONVERSION KIT covers the boiler's installation at an altitude of 0 to 10,100 ft.

⚠ WARNING

Ensure that the High Altitude setting reflects the actual location of the boiler. If not, it may cause personal injury or malfunction of the boiler.

⚠ WARNING

To prevent serious injury or death:

- ALWAYS check the panel DIP SW2 #1 (Set of 8 Switches) is set according to the supply gas type.
- For natural gas, only install the gas orifice for high altitude when the boiler is installed at above 5,400 ft.
- Be careful to install the NATURAL GAS HIGH ALTITUDE CONVERSION KIT and not to confuse it with the PROPANE GAS & HIGH ALTITUDE CONVERSION KIT.
- Failure to properly install the High Altitude Conversion Kit or to not use the appropriate Altitude Settings could cause carbon monoxide poisoning, resulting in serious injury or death.

15. Turn on the gas and water supply to the boiler.

16. Measure and adjust the gas/air ratio.

Option 1. Using Combustion Analyzer (recommended)

- a. Remove the analyzer port's cap.
- b. Insert the analyzer into the port (Figure 7).

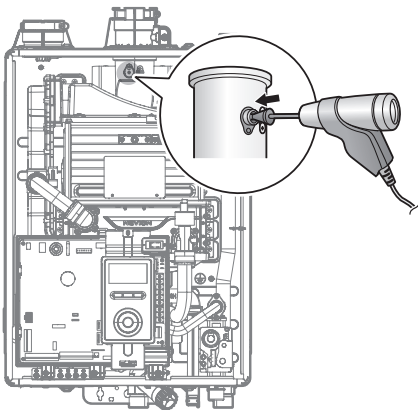

Figure 7. Insert the Analyzer

The DIP SW1 (Set of 6 Switches) on the circuit board configures the operation status and model settings.

Model	Fuel	High fire	Low fire
		%CO ₂	%CO ₂
NHB-055H	NG	8.9	9.5
	LP	10.2	10.8
NHB-080H	NG	8.9	9.5
	LP	10.2	10.8
NHB-110H	NG	8.9	9.5
	LP	10.2	10.8
NHB-150H	NG	8.9	9.5
	LP	10.2	10.8

Table 2. CO₂ value

(CO₂ values must be within 0.5% of the values listed.)

- c. Activate multiple zones and set the boiler to operate at 1-stage MIN mode.

Note For operation mode selection, refer to "11.13.7 Setting the Special Operation Modes" on page 118.

Measure the CO₂ value at low fire.

If the CO₂ value is not within 0.5% of the value listed in Table 2, the gas valve set screw will need to be adjusted.

If adjustment is necessary, locate the set screw as shown in Figure 8. Using a 5/32 in or 4 mm Allen wrench, turn the set screw no more than 1/4 turn clockwise to raise or counterclockwise to lower the CO₂ value.

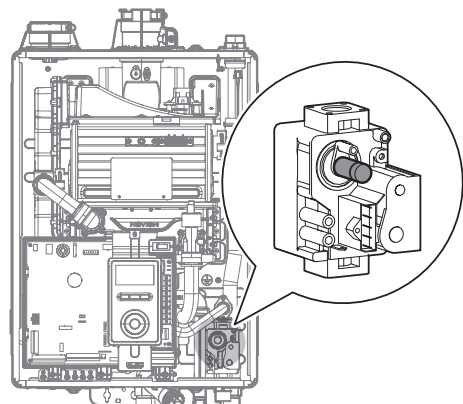

Figure 8. Set Screw Location

Note The set screw is located behind the screw-on cover. This must be removed first.

- d. Activate multiple zones and set the boiler to operate at 2-stage D. MAX mode (refer to “11.13.7 Setting the Special Operation Modes” on page 118). Measure the CO₂ value at high fire.
If the CO₂ values do not match Table 2 at high fire, do not adjust the gas valve. Check for the proper Gas Orifice.

⚠ WARNING

Improper gas valve settings can cause severe personal injury, death or substantial property damage.

Option 2. Using Digital Manometer

- a. Open the offset pressure port by loosening the screw two turns as shown in Figure 9.

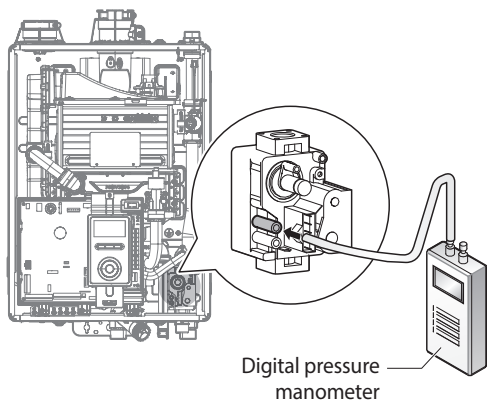

Figure 9. Connect Digital Pressure Monometer

- b. Connect a manometer to the offset pressure port. For dual port manometers, use the positive pressure side.

Model	Kit Part No.	Gas Type	Offset
NHB-055/080H	NAC-NH055-080	NG	-0.04 in ±0.01 in
	NAC-L055/080	LP	-0.02 in ±0.01 in
NHB-110H	NAC-NH110	NG	-0.04 in ±0.01 in
	NAC-L110	LP	-0.02 in ±0.01 in
NHB-150H	NAC-NH150	NG	-0.04 in ±0.01 in
	NAC-L150	LP	-0.02 in ±0.01 in

Table 3. Offset value for low fire

- c. Activate multiple zones and set the boiler to operate at 1-stage MIN mode (refer to “11.13.7 Setting the Special Operation Modes” on page 118). Measure the offset value at low fire and compare it to the values in Table 3. If the offset value is out of range, the gas valve set screw will need to be adjusted.

If adjustment is necessary, locate the set screw as shown in Figure 10. Using a 5/32 in or 4 mm Allen wrench, turn the set screw no more than 1/4 turn clockwise to raise or counterclockwise to lower the offset value.

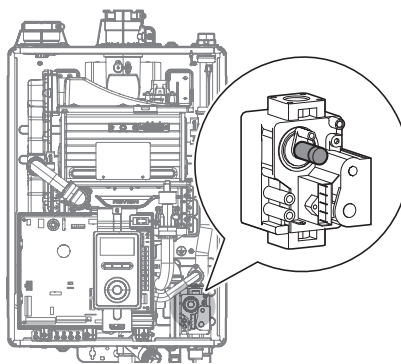

Figure 10. Set Screw Location

Note The set screw is located behind the screw-on cover. This must be removed first.

- d. At high fire, do not check the offset value and never adjust the gas valve.

⚠ WARNING

Improper gas valve settings can cause severe personal injury, death or substantial property damage.

17. Once the CO₂ or offset values have been confirmed, apply the included conversion stickers to show that the appliance has been converted to Propane Gas or High Altitude. Place these labels adjacent to the rating plate as shown in Figure 11.



Figure 11. Proper Placement of Gas Conversion Labels

Note The gas conversion rating plate varies depending on the model. Check the conversion kit number before attaching the labels.

12.2 Wiring Diagram

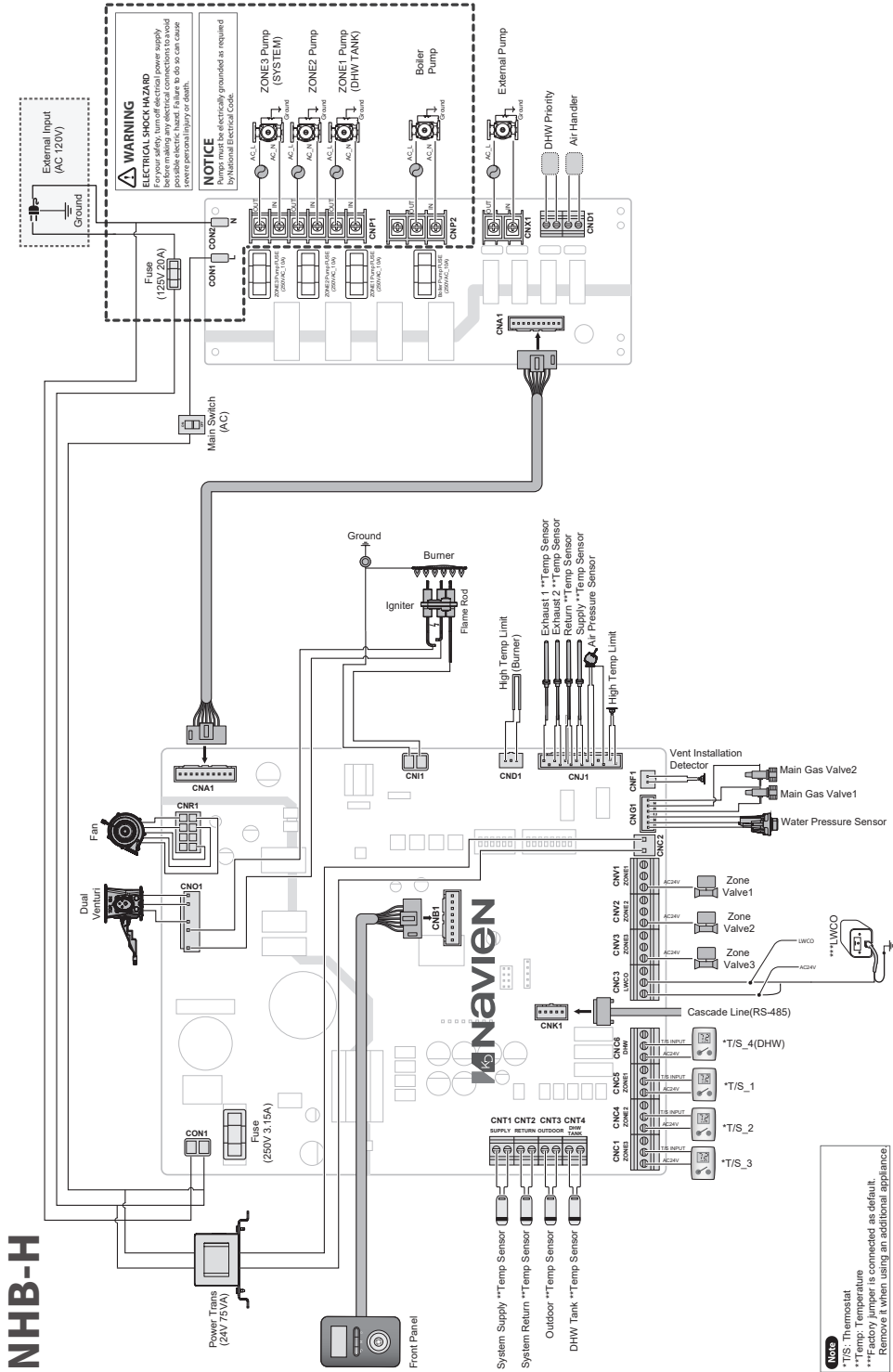

12.3 Ladder Diagram

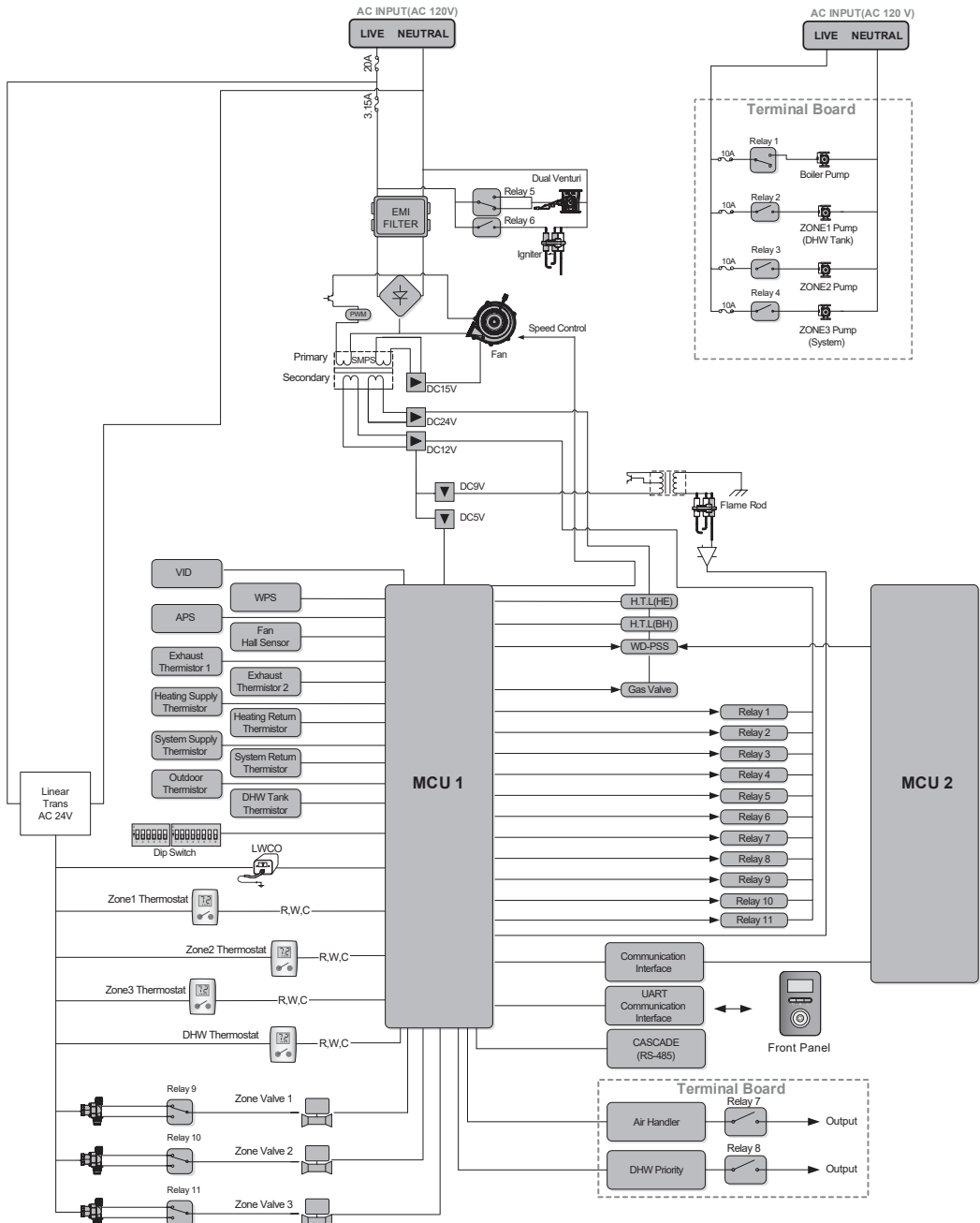

12.4 Outdoor Temperature Sensor

Outdoor Temperature Sensor

Installation

1. Pull out the sensor body from the cap.
2. Attach the body to the wall using the screws/anchors provided with the device.
3. Run the wires into the device body through the grommet opening.
4. Connect the wires to the terminal block.
5. Attach the cap to the body.

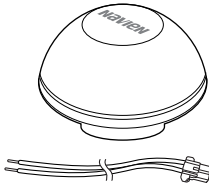

Navien Outdoor Temperature Sensor Kit

Outdoor Temperature Sensor Installation Guidelines

- Avoid areas with temperature fluctuations by direct sunlight, and where the temperature may not be representative of true outdoor temperature.
- Best location to install the temperature sensor is on a North or Northeast side of a structure under eaves where the sensor is shielded from direct sunlight.
- Avoid placing sensor in close proximity of heat sources that may affect correct temperature sensing. (fans, exhausts, vents, lights)
- Avoid installing the sensor in areas where the sensor is subjected to excessive moisture.
- Use 18 gauge wiring (thermostat wiring) with no splices.
- Caution should be taken to avoid potential electromagnetic interference (EMI) by routing separately from potential sources such as line voltage wiring. When necessary, shielded cable may be used.
- Make sure wiring connections are secure before closing the cap.
- The sensor is a water resistant device.
- Any damage to the device may require the replacement of the entire component.

12.5 Outdoor Reset Control

The Outdoor Reset Control feature may be used to enhance energy efficiency while maintaining optimal heating performance. With the Outdoor Reset Control, the space heating temperature setting automatically changes according to the outdoor temperature and the current space heating system application (system load).

You can configure the Outdoor Reset Control settings on the front panel. Refer to "11.8 Setting the Space Heating Operation" on page 104 and "11.13.3 Setting the Operation Parameters" on page 111.

Note

The Outdoor Reset Control feature requires installation of an outdoor temperature sensor, and it only works when the boiler is running in the normal operation mode. It does not work when the boiler is running in either the Minimum (MIN) or Maximum (MAX) mode, or when the boiler's front panel displays a fault.

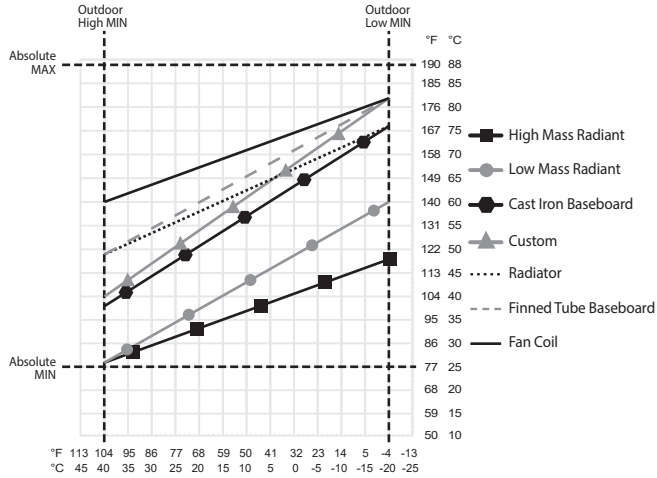

Space Heating Temperature Setting for the Outdoor Reset Control Feature

The following tables list the default space heating temperature range by system heat load and the applicable outdoor temperature ranges.

Outdoor Temperature Sensor Installation Guidelines

Heat Load	Supply Set Point Range	Return Set Point Range
Finned Tube Baseboard (default)	120-180°F (48.5-82°C)	101-147°F (38-63.5°C)
Fan Coil	140-180°F (60-82°C)	116-147°F (46.5-63.5°C)
Cast Iron Baseboard	100-170°F (37.5-76.5°C)	86-139°F (30-59°C)
Low Mass Radiant	80-140°F (26.5-60°C)	70-116°F (21-46.5°C)
High Mass Radiant	80-120°F (26.5-48.5°C)	70-101°F (21-38°C)
Radiators	120-170°F (48.5-76.5°C)	101-139°F (38-59°C)
Custom	104-180°F (40-82°C)	86-149°F (30-65°C)

Outdoor Temperature Range and Default Temperature Settings

Set Point	Range	Remarks
Outdoor Low Temperature	-4°F (-20°C) to Outdoor High Temperature Set Point - 9°F (5°C)	Default: 14°F (-10°C)
Outdoor High Temperature	Outdoor Low Temperature Set Point + 9°F (5°C) to 104°F (40°C)	Default: 70°F (21°C)

12.6 Component Assembly Diagrams and Parts Lists

12.6.1 Case Assembly

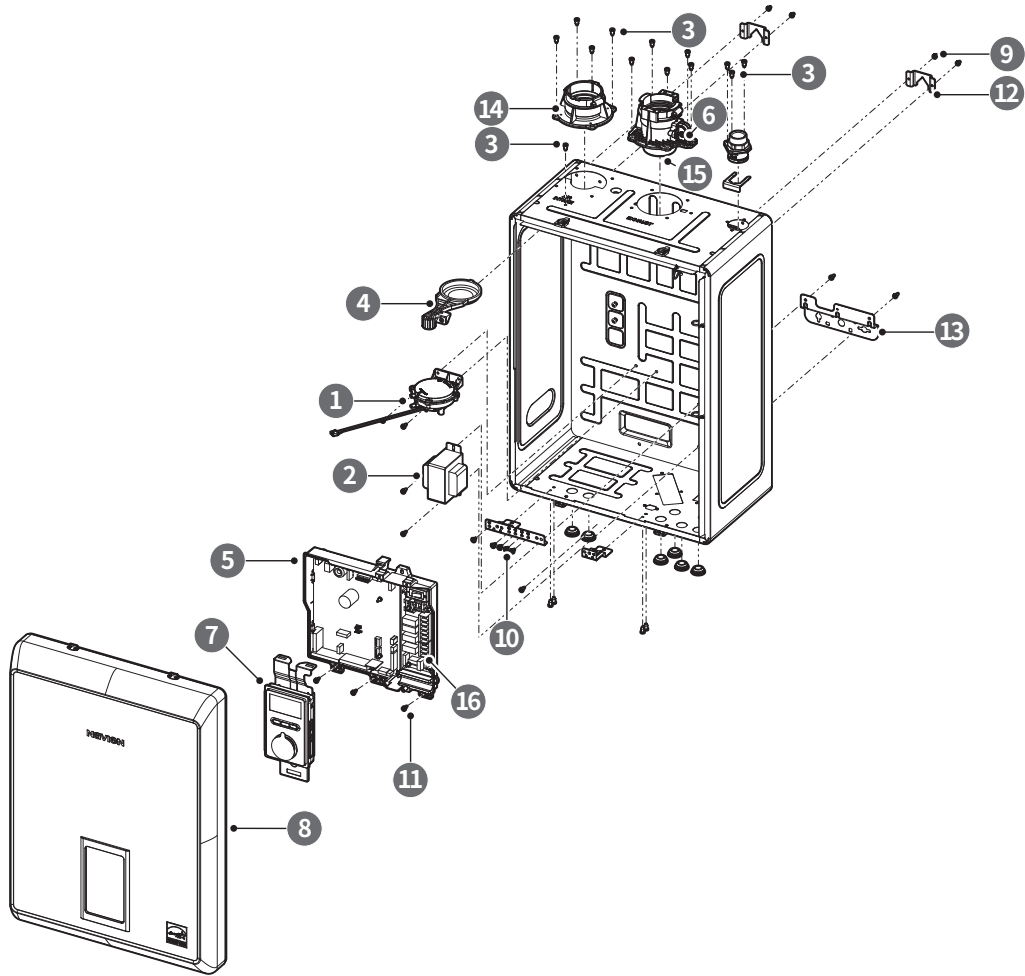

#	Description	Service Code	Part #	Remark
1	Air Pressure Sensor	30021100B	30021100*	
2	24V Power Transformer	30025710A	30025710*	
3	Screw (M4X10)	20049000A	20049000*	
4	Intake Air Filter	30016248B	30016248*	
5	Main PCB	30033380A	30031846*	
6	Vent Installation Detector	30024849A	30024849*	
7	Front Panel	30019664C	30019664*	
8	Front Cover	30032869A	30031942*	
9	Screw (M4X6)	20038859A	20038859*	
10	Screw (M4X8)	20006540A	20006540*	
11	Screw (M4X14)	20038754A	20038754*	
12	Case Bracket (Upper)	20007609A	20007609*	
13	Case Bracket (Lower)	20061907A	20061907*	
14	Intake Vent Collar Ass'y	30008662B	30008662*	
15	Exhaust Vent Collar Ass'y	30024848B	30024848*	
16	Terminal PCB	30019913A	30019913*	
-	Screw (S1021B, 4X14)	20023656A	20023656*	Screws to assemble heat exchanger to the case
-	Screw (STS430, M4X10)	20038758A	20038758*	Screws to assemble the water pipes

12.6.2 Heat Exchanger and Waterway Assembly

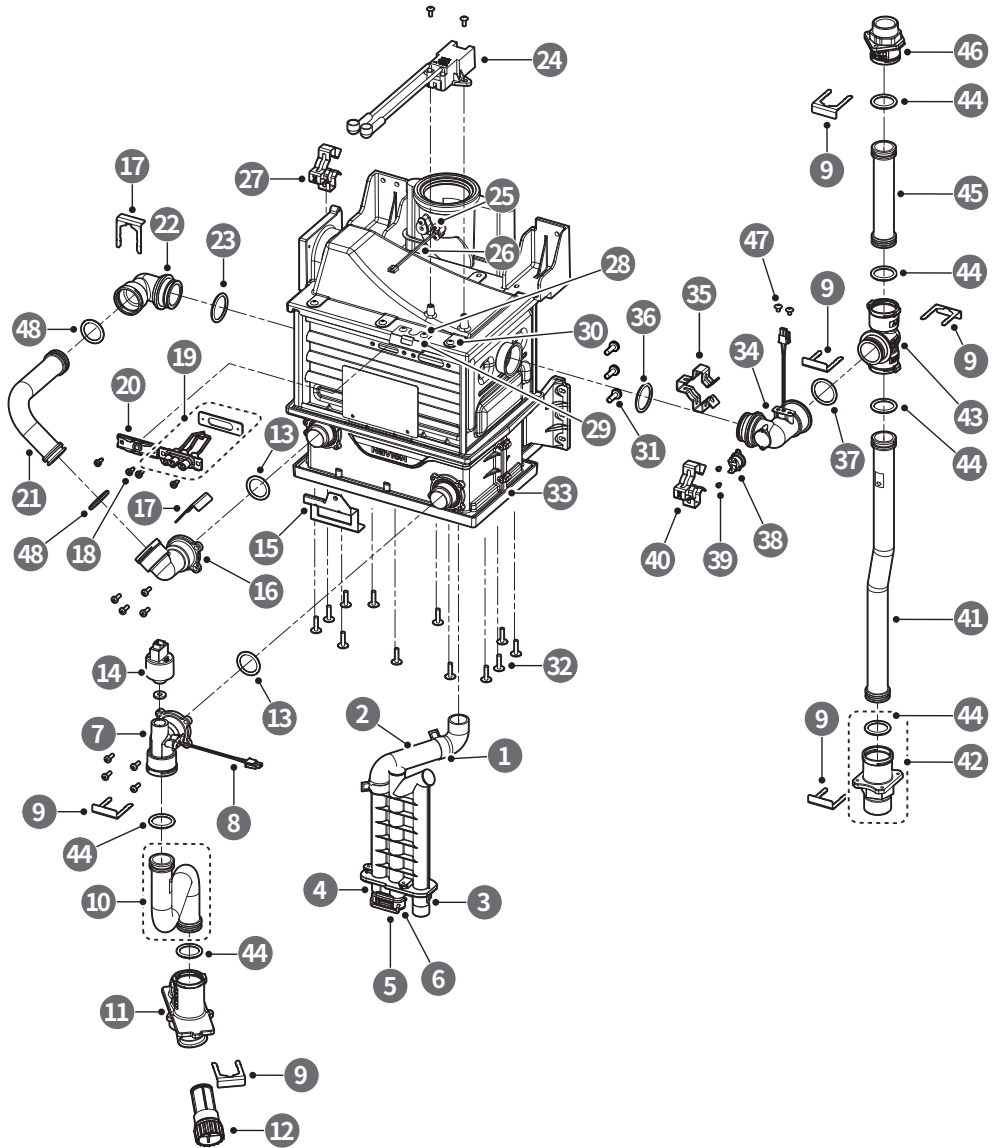

#	Description	Service Code	Part #	Remark
1	Siphon Pipe Clip	20007833A	20007833*	
2	Siphon Hose	20061755A	20061755*	NHB-55/80H
		20061754A	20061754*	NHB-110/150H
3	Siphon	30031953A	30031953*	NHB-55/80H
		30031992A	30031992*	NHB-110/150H
4	Condensate Trap Clip	20048219A	20048219*	
5	Condensate Trap Cap	20048216B	20048216*	
6	Condensate Trap Gasket	20048240A	20048240*	
7	Heat Exchanger Inlet Adapter	30014065A	30014065*	NHB-55/80H
		30014055A	30014055*	NHB-110/150H
8	Water Return Thermistor	30012907A	30012907*	
9	Clip	20033662A	20033662*	NHB-55/80H
		20046546A	20046546*	NHB-110/150H
10	Return Pipe	30031852A	30031852*	NHB-55/80H
		30031851A	30031851*	NHB-110/150H
11	Return Adapter	30032091A	30032091*	NHB-55/80H
		30031991A	30031991*	NHB-110/150H
12	O-ring	20032528A	20032528*	
13	O-ring	20006949A	20006949*	NHB-55/80H
		20032528A	20032528*	NHB-110/150H
14	Pressure Sensor	30014699A	30014699*	
15	Bracket	20061753A	20061753*	NHB-55/80H
		20061752A	20061752*	NHB-110/150H
16	Heat Exchanger Connection Adapter 1	20033548A	20033548*	NHB-55/80H
		20033545A	20033545*	NHB-110/150H
17	Pipe Clip	20017726A	20017726*	NHB-55/80H
		20046546A	20046546*	NHB-110/150H
18	Screw (S18A, 4X10)	20038753A	20038753*	
19	Flame Rod	30032870A	30031997*	
20	Flame Inspection Window Ass'y	30028669A	30028669*	
21	Heat Exchanger Middle Pipe	30013504A	30013504*	NHB-55/80H
		30013503A	30013503*	NHB-110/150H
22	Heat Exchanger Connection Adapter 2	20026920A	20026920*	NHB-55/80H
		30014253A	30014253*	NHB-110/150H
23	O-ring (P31)	20032163A	20032163*	NHB-55/80H
	O-ring	20006949A	20006949*	NHB-110/150H
24	Ignition Transformer	30026063A	30026063*	
25	Screw (STS430, M4X10)	20019083A	20019083*	

#	Description	Service Code	Part #	Remark
26	Exhaust Thermistor	30009478A	30009478*	
27	Fastener	20007853A	20007853*	NHB-55/80H
		20017724A	20017724*	NHB-110/150H
28	Screw (S10A, M4X8)	20024322A	20024322*	
29	Bracket	20033938A	20033938*	
30	Screw (STS410, 4X16)	20037260A	20037260*	
31	Screw (STS410, 4X12)	20006487A	20006487*	
32	Screw (STS410, 4X18)	20023655A	20023655*	
33	Heat Exchanger Assembly	30032871A	30031943*	NHB-55H
		30032873A	30031944*	NHB-80H
		30032875A	30031985*	NHB-110H
		30032877A	30031986*	NHB-150H
34	Heat Exchanger Outlet Adapter	30031947A	30031947*	NHB-55/80H
		30014032A	30014032*	NHB-110/150H
35	Fastener	20033662A	20033662*	NHB-55/80H
		20017724A	20017724*	NHB-110/150H
36	O-ring (P22A)	20033699A	20033699*	NHB-55/80H
	O-ring (P31)	20032163A	20032163*	NHB-110/150H
37	O-ring (P22A)	20033699A	20033699*	NHB-55/80H
	O-ring (P29)	20017923A	20017923*	NHB-110/150H
38	High Limit Switch	30023954A	30023954*	
39	Screw (M3X4)	20006384A	20006384*	
40	Fastener	20033659A	20033659*	NHB-55/80H
		20017724A	20017724*	NHB-110/150H
41	Supply Pipe (Lower)	30031850A	30031850*	NHB-55/80H
		30031849A	30031849*	NHB-110/150H
42	Supply Adapter	20033713A	20033713*	NHB-55/80H
		20063355A	20063355*	NHB-110/150H
43	Heating Supply Adapter	30014259A	30014259*	NHB-55/80H
		30031989A	30031989*	NHB-110/150H
44	O-ring	20033699A	20033699*	NHB-55/80H
		20032528A	20032528*	NHB-110/150H
45	Supply Pipe (Upper)	30031995A	30031995*	NHB-55/80H
		30031996A	30031996*	NHB-110/150H
46	Air Vent Adapter	30031951A	30031951*	NHB-55/80H
		30032804A	30032804*	NHB-110/150H
47	Screw (M4X6)	20006461A	20006461*	
48	O-ring	20003022A	20003022*	NHB-55/80H
		20032528A	20032528*	NHB-110/150H

12.6.3 Fan(Gas) Assembly

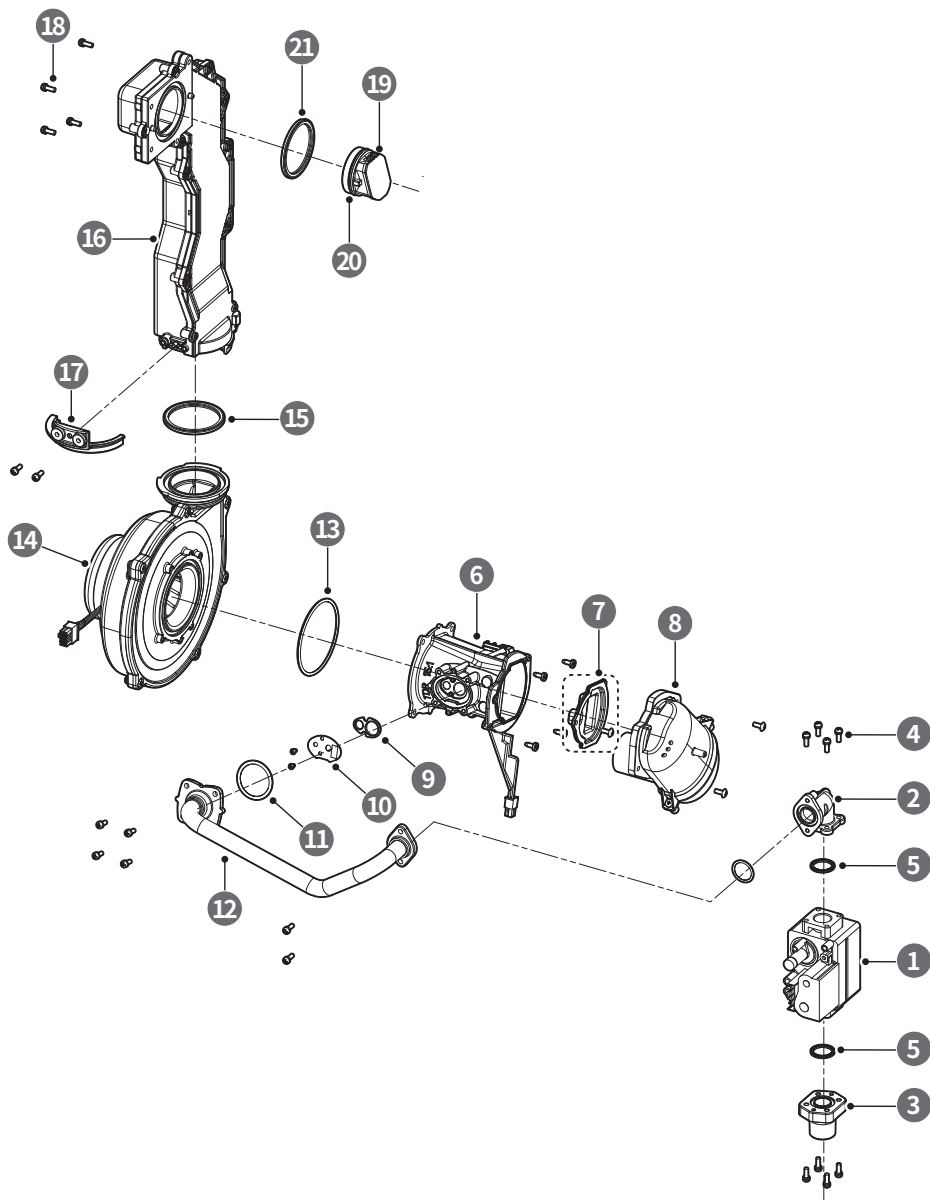

#	Description	Service Code	Part #	Remark
1	Gas Valve	30011586B	30011586*	
2	Gas Connector	20027149A	20027149*	
3	Gas Inlet Adapter	20027748A	20027748*	
4	Screw (SCM435, M4X12)	20006390A	20006390*	
5	O-ring	20058408A	20058408*	
6	Dual Venturi	30027149B	30027149*	
7	Reducer	30031949A	30031949*	NHB-55/80H
		30024970A	30024970*	NHB-110/150H
8	Intake Pipe	30031906A	30031906*	NHB-55/80/110H
		30024867A	30024867*	NHB-150H
9	Packing Nozzle	20022660A	20022660*	
10	Orifice	20061838A	20061838*	NHB-55/80H (NG)
		30031956A	20061840*	NHB-55/80H (LP)
		20062919A	20062919*	NHB-110H (NG)
		30031993A	20062891*	NHB-110H (LP)
		20061839A	20061839*	NHB-150H (NG)
		30031994A	20061841*	NHB-150H (LP)
		30031958A	20062892*	NHB-55/80H (HIGH ALTITUDE)
		30032384A	20062893*	NHB-110H (HIGH ALTITUDE)
11	O-ring	20019090A	20019090*	
		30031848A	30031848*	NHB-55/80H
12	Gas Pipe	30031847A	30031847*	NHB-110/150H
		20018079A	20018079*	
13	O-ring (G75)	20018079A	20018079*	
14	Fan Assembly	30033392A	30032015*	NHB-55/80H
		30025295A	30025295*	NHB-110/150H
15	Fan Gasket	20033847A	20033847*	
16	Gas Mixing Tube	30013458A	30013458*	NHB-55/80H
		30015213A	30015213*	NHB-110/150H
17	Bracket	20030471A	20030471*	
18	Screw (S10A, M4X12)	20024325A	20024325*	
19	Fan Damper	30008825A	30008825*	
20	O-ring (G50)	20003019A	20003019*	
21	Fan Gasket	20022744A	20022744*	

12.7 Requirements for the State of Massachusetts

NOTICE BEFORE INSTALLATION

This appliance must be installed by a licensed plumber or gas fitter in accordance with the Massachusetts Plumbing and Fuel Gas Code 248 CMR Sections 4.00 and 5.00.

IMPORTANT: In the State of Massachusetts (248 CMR 4.00 & 5.00)

For all side wall horizontally vented gas fueled equipment installed in every dwelling, building or structure used in whole or in part for residential purposes, including those owned or operated by the Commonwealth and where the side wall exhaust vent termination is less than seven (7) feet above finished grade in the area of the venting, including but not limited to decks and porches, the following requirements shall be satisfied:

1. INSTALLATION OF CARBON MONOXIDE DETECTORS. No installation or replacement of a vented gas appliance shall be permitted unless a battery powered or electrically hard wired carbon monoxide detector is present on the same floor as the appliance or on the next adjacent floor when the appliance is located in a crawl space unless the appliance is located in a detached, uninhabitable garage. For all residential dwellings, a carbon monoxide detector must also be present on each habitable level of the dwelling. These requirements shall not be deemed to waive any additional requirements imposed by M.G.L. c. 148 §26F1/2.
2. APPROVED CARBON MONOXIDE DETECTORS. Each carbon monoxide detector as required in accordance with the above provisions shall comply with NFPA 720 and be ANSI/UL 2034 listed and IAS certified.
3. SIGNAGE. Whenever any through-the-wall vent is installed less than seven feet above the finished grade, a metal or plastic identification plate shall be permanently mounted to the exterior of the building at a minimum height of eight feet above grade directly in line with the exhaust vent terminal. The sign shall read, in print size no less than 0.5 inches in size, **"GAS VENT DIRECTLY BELOW. KEEP CLEAR OF ALL OBSTRUCTIONS"**.
4. INSPECTION. The state or local gas inspector of the side wall horizontally vented gas fueled equipment shall not approve the installation unless, upon inspection, the inspector observes carbon monoxide detectors and signage installed in accordance with the provisions of 248 CMR 5.09 and 5.12.

13. LIMITED WARRANTY NAVIEN, INC.

Effective

This 10/15 year limited pro-rated warranty on heat exchangers, 3/5 year limited warranty on parts, and 1 year limited warranty on labor ("Warranty") covers defects in materials or workmanship when the Navien NHB-H Boiler ("Product") is installed by a properly licensed plumber or contractor and operated in strict compliance with the Installation and Operation Manual procedures, subject to the terms within this Warranty document. Improper installation or use will void this Warranty. This Warranty runs from date of installation and extends to the original purchaser and subsequent owners, but only while the Product remains at the site of the original installation. This Warranty includes both a limited and pro-rated warranty as set forth below.

What is covered?

Subject to the foregoing terms, Navien will repair or replace the covered Product or any part or component that is defective in materials or workmanship for a period of five (5) years in regard to parts and up to ten (10) Years in regard to the heat-exchanger. Navien will pay labor charges for the repair subject to Navien's prior written approval and in accordance with Navien's schedule of approved labor allowances for a period of one (1) year from the date of installation. All repair parts must be genuine Navien parts. All repairs and replacements must be performed by an individual or servicing company that is properly licensed to do the type of repair.

When the Product is or has ever been used for anything other than single family residential application (hereinafter "Commercial") then the parts warranty will be reduced to three (3) years and the heat exchanger warranty to seven (7) years.

The heat exchanger is covered by Navien's pro-rated limited residential Warranty for defects in material and workmanship at a cost to the customer equal to a percentage of the Manufacturer's Suggested Retail Price (MSRP), at the time the warranty claim is approved by Navien, as indicated in the following Coverage Table for Heat Exchangers Only. This pro-rated warranty only applies to the replacement of the heat exchanger and does not include labor, shipping, other parts, delivery or installation. In order to obtain this warranty, the customer must pay the applicable pro-rated amount as indicated in the following Coverage Table for Heat Exchangers Only. Once the customer pays the pro-rated amount, then Navien will ship the heat exchanger directly to the service provider.

During the applicable warranty period, replacement of the Product or components may be authorized by Navien only. Navien does not authorize any person or company to assume for it any obligation or liability in connection with the replacement of the Product or its components. If it is determined that repair or replacement of a part, under warranty, is not possible, the Product will be replaced with a new Product having at least the same BTU capacity as the product at issue. The replacement component or product will be warranted only for the unexpired portion of the applicable warranty period for the original component or Product.

Coverage Table for Labor and Parts Only			
Residential*		Commercial	
Labor	1 year	Labor	1 year
Parts	5 years	Parts	3 years

* Applies only to single family, residential locations.

Coverage Table for Heat Exchangers Only			
Residential*		Commercial	
Years	Percentage Paid by Customer	Years	Percentage Paid by Customer
1 to 10	0%	1 to 7	0%
11	30%	8	50%
12	40%	9	60%
13	50%	10	70%
14	60%		
15	70%		

* Applies only to single family, residential locations.

How do I get service?

You must contact the original installer of your Product. Your installer will need to contact Navien to report the issue. If the original installer cannot be identified or you no longer choose to use that service provider, you may choose any service provider who is properly licensed to complete the necessary repair. The installer and/or service provider must comply with Navien's warranty service and return policy procedures as available on Navien's website including contacting Navien's Technical Support Department at (800) 519-8794, option 2, prior to commencing any service.

Proof of the date of installation must be provided to Navien. At Navien's request, the defective Product or part must be returned to Navien. When the Product is installed in new construction, the date of installation shall be established as the date upon which the end-user takes title to the real property. If proof of the installation date is unavailable, then six months after the date of manufacture will be used.

Additional terms and conditions are continued on the reverse side.



Customer Name :	
Customer Address :	
Telephone :	Fax :
Email :	
Installer Name :	License No :
Installer Address :	
Place of Purchase :	
Model No :	
Serial No :	
Date of Purchase :	



Navien, Inc.

20 Goodyear, Irvine, CA 92618
 Tel : 1-800-519-8794
 Fax : 949-420-0430
 www.navieninc.com

For instant warranty registration, please register your product online at www.navieninc.com

What is not covered?

Navien's Limited Warranty shall be void in the event of an occurrence of any of the following:

- Improper installation, including but not limited to, installation in violation of applicable rules, laws or building codes, inadequate water quality, condensate damage, improper venting, incorrect gas type, water pressure, absence of a drain pan, improper conversion from Natural Gas source to Propane, reinstallation at another location, etc.
- Accident, abuse or misuse including but not limited to installation for non-recommended uses, failure to follow or comply with the User's Information Manual, etc.
- Improper maintenance including but not limited to, scale buildup, vent blockage, failure to maintain, etc.
- Modification, alteration, addition of non-approved components, or misapplication of the Product in any manner.
- Any damage caused by local adverse conditions including but not limited to water quality, hard water deposits, lime or mineral build-up, operating in corrosive atmospheric elements, alterations in smell or taste of water that have an adverse reaction on the unit, etc.
- Damage or problems caused by gas flow issues, electrical surges, flooding, fire, freezing, abnormal external temperature, force majeure, riot, act of war, or any acts of God.
- Performance problems caused by improper sizing of the boiler, the gas supply line, the venting connection, combustion air openings, electric service voltage, wiring, fusing or any other components, parts or specifications.
- Vibration and noise unless caused by a defect in materials or workmanship. Any other causes other than defects in materials or workmanship.
- Operating the Product at water temperatures outside the factory calibrated temperature limits and/or exceeding the maximum setting of the high limit control.
- Subjecting the heat exchanger to pressures or firing rates greater or lesser than those shown on the rating plate or removal of or alteration to the rating plate.
- Installation at any location outside the United States or Canada.
- Improper conversion from natural gas to liquid propane gas or liquid propane gas to natural gas or attempt to operate with a type of gas not specified for the boiler.
- Accidental or intentional damage.

There is no warranty on any Product purchased through the internet or from any installer that obtained the Product from a supplier or distributor not authorized by Navien.

Warranty Limitations

EXCEPT AS EXPRESSLY PROVIDED HEREIN, THERE ARE NO OTHER WARRANTIES, EXPRESSED OR IMPLIED, INCLUDING, BUT NOT LIMITED TO WARRANTIES OR MERCHANTABILITY OR FITNESS FOR A PARTICULAR PURPOSE, WHICH EXTEND BEYOND THE DESCRIPTION OF THE WARRANTY HEREIN AND FURTHER NAVIEN SHALL NOT BE LIABLE FOR INDIRECT, INCIDENTAL, SPECIAL, CONSEQUENTIAL, PUNITIVE OR OTHER SIMILAR DAMAGES THAT MAY ARISE, INCLUDING LOST PROFITS, DAMAGE TO A PERSON OR PROPERTY, LOSS OF USE, INCONVENIENCE, OR LIABILITY ARISING FROM IMPROPER INSTALLATION, SERVICE OR USE OF THE PRODUCT. ANY IMPLIED WARRANTIES OF MERCHANTABILITY AND FITNESS ARISING UNDER STATE LAW ARE LIMITED IN DURATION TO THE PERIOD OF COVERAGE PROVIDED BY THIS WARRANTY, UNLESS THE PERIOD PROVIDED BY STATE LAW IS LESS.

No one is authorized to make any other warranties on behalf of Navien. Some states do not allow the exclusion or limitation of incidental or consequential damages, or how long an implied warranty lasts, so the above limitation may not apply to you.

This Limited Warranty gives you specific legal rights and you may also have other rights which vary from state to state.

Rev. 9.8.2023

Retain this document for future reference.



Installation and Operation Manual

NHB-H Condensing Boilers

Getting Service

If your boiler requires service:

- All repairs require pre-authorization by Technical Support.
- Request for your installer or any licensed professional to contact Technical Support at 1-800-519-8794 Option 2 once at the installation site.
- A short list of independent service providers in your area can be found on the website: www.navienc.com/installers.
- Contact a licensed professional for the affected system (for example, a plumber, gas fitter, or electrician).

When you contact Technical Support, please have the following information at hand:

- Model number
- Serial number
- Date purchased
- Installation location and type
- Error code, if any appears on the front panel display.

Version: 1.0 (February, 2024)



800.519.8794 | www.navienc.com
20 Goodyear Irvine, CA 92618