

Installation Manual

NHW700 Non-Condensing Water Heaters

Model | NHW700-160SE/180SE/199SE
NHW700-160SU/180SU/199SU
NHW700-160AI/180AI/199AI
NHW700-160AE/180AE/199AE



* Lead Free

ALWAYS read and follow this manual completely before using the water heater. Save for future reference.

Tested and Certified to NSF/ANSI 372 for lead free* compliance.

* The wetted surface of this product contacted by consumable water contains less than one quarter of one percent (0.25%) of lead by weight.

WARNING

If the information in these instructions is not followed exactly, a fire or explosion may result, causing property damage, personal injury, or death.

Do not store or use gasoline or other flammable vapors and liquids in the vicinity of this or any other appliance.

WHAT TO DO IF YOU SMELL GAS

- Do not try to light any appliance.
- Do not touch any electrical switch; do not use any phone in your building.
- Immediately call your gas supplier from a neighbor's phone. Follow the gas supplier's instructions.
- If you cannot reach your gas supplier, call the fire department.

Installation and service must be performed by a qualified installer, service agency or the gas supplier.

The installation must conform with local codes or, in the absence of local codes, the National Fuel Gas Code, ANSI Z223.1/NFPA 54.

When applicable, the installation must conform with the Manufactured Home Construction and Safety Standard, Title 24 CFR, Part 3280.

Do not install this water heater in a recreational vehicle, trailer, boat or other moving vehicles as it will result in a Carbon Monoxide Poisoning Hazard.

Contents

1. Important Safety Information	3	6. Appendixes	68
2. About the Water Heater	6	6.1 Covering the Clamps with Front Cover Cap (for NSF 5 Use Only)	68
2.1 Included Items	6	6.2 Technical Data	69
2.2 Accessories	6	6.3 Wiring Diagram	72
2.3 Specifications	7	6.4 Ladder Diagram	73
2.4 The Front Panel	8	6.5 Component Assembly Diagrams and Parts Lists	74
2.5 Components	9	6.6 Installation Check list	93
2.6 Dimensions	13	6.7 Navien H2Air Add-on Controller Kit (Optional)	95
2.7 Rating Plate	17	6.8 Requirements for the State of Massachusetts	97
3. Installing the Water Heater	18	7. LIMITED WARRANTY NAVIEN, INC.	98
3.1 Choosing an Installation Location	18		
3.2 Mounting the Water Heater to the Wall	22		
3.3 Connecting the Gas Supply	23		
3.4 Connecting the Water Supply	29		
3.5 Venting the Water Heater (Universal/ Interior Models Only)	43		
3.6 Connecting the Power Supply	54		
3.7 Setting the DIP Switches	55		
4. Configuring the Remote Controller System	58		
4.1 Included Items	58		
4.2 Connecting the Extension Cable	58		
4.3 Attaching the Wall Mounting Bracket	58		
4.4 Remote Controller	59		
4.5 Multi Remote Controller System	60		
4.6 Entering Lock Mode	62		
4.7 Setting the Clock	62		
4.8 Setting the Recirculation Timer	63		
4.9 Starting Recirculation	64		
4.10 Canceling all Timer Settings	64		
5. Installing a Cascade System	65		
5.1 Connecting Water Supplies	65		
5.2 Connecting the Communication Cables	67		

Product Installation Information	
Model	
Date Purchased	
Gas Type	
Serial Number	

1. Important Safety Information

 The following Safety Alert Symbols are used in this manual. They are used to alert you to potential personal injury hazards. Obey all safety messages that follow this symbol to avoid possible serious injury or death. This Safety Alert Symbol precedes any safety message about risk of personal injury. It may also be accompanied by one of the following signal words.

If the information in these instructions is not followed exactly, a fire or explosion may result, causing property damage, personal injury or death.

DANGER

Indicates a hazardous situation that if not avoided will result in death or serious injury.

WARNING

Indicates a hazardous situation that if not avoided could result in death or serious injury.

CAUTION

Indicates a potentially hazardous situation that if not avoided could result in minor or moderate injury.

NOTICE

Indicates information considered important but not hazard-related (such as property damage).

DANGER

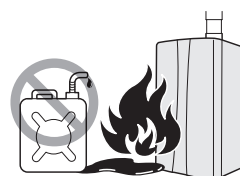

If you smell gas:

- Do not try to light any appliance.
- Do not touch any electrical switches or use landline phones.
- From a neighbor's phone, call your gas provider and follow their instructions.
- If you cannot reach your gas provider, call the fire department.

Do not use or store flammable products, such as gasoline, solvents, or adhesives in the same room or area as the water heater.

- The water heater has a main burner flame that can turn on at any time and can ignite flammable vapors. Vapors from flammable liquids can explode and catch fire, causing death or severe burns.
- Vapors cannot be seen and are heavier than air. They can travel long distances along the ground and can be carried from other rooms to the water heater's main burner flame by air current.
- Keep all flammable products far away from the water heater and store them in approved containers. Keep the containers closed tightly and out of the reach of children and pets.

⚠ WARNING

To prevent death, serious injury, or property damage:

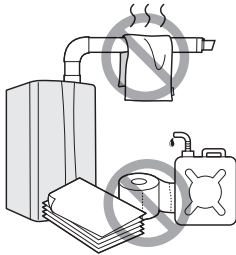

- **Do not store or use gasoline or other flammable liquids near this water heater.**
Doing so may result in fire or explosion.
- **Do not place combustibles, such as newspapers or laundry, near the water heater or venting system.**
Doing so may result in a fire.
- **Do not place or use hair sprays, spray paints, or any other compressed gases near the water heater or venting system, including the vent termination.**
Doing so may result in fire or explosion.
- **Do not remove the front cover unless the power to the water heater is turned off or disconnected.**
Failure to do so may result in electric shock.
- **Do not operate the water heater with the front cover opened.**
Doing so may result in fire or carbon monoxide (CO) poisoning, which may result in property damage, personal injury, or death.
- **Do not operate this water heater without proper venting.**
Doing so may result in fire or carbon monoxide (CO) poisoning, which may result in property damage, personal injury, or death.
- **Do not touch the power cord or internal components of the water heater with wet hands.**
Doing so may result in electric shock.

California law requires the following Prop 65 warning to be provided:

⚠ WARNING

Cancer and Reproductive Harm -
www.P65Warnings.ca.gov

⚠ WARNING

To prevent death, serious injury, or property damage:

- **Do not turn on the water heater unless the water and gas supplies are fully opened.**
Doing so may damage the water heater.
- **Do not turn on the water if the cold water supply shut-off valve is closed.**
Doing so may damage the water heater.
- **Do not use this water heater for anything other than its intended purpose, as described in this manual.**
- **When servicing the controls, label all wires prior to disconnecting them.**
Failure to do so may result in wiring errors, which can lead to improper or dangerous operation. Verify proper operation after servicing.
- **Do not use unapproved replacement or accessory parts.**
Doing so may result in improper or dangerous operation and will void the manufacturer's warranty.
- **Do not place anything in or around the vent terminals, such as a clothes line, that could obstruct the air flow in or out of the water heater.**
- **This water heater has been approved for use in the USA only.**
Using the water heater in any other country will void the manufacturer's warranty.

⚠ DANGER



Water temperatures over 125°F (52°C) can cause severe burns instantly or death from scalds. Children, disabled and elderly are at highest risk of being scalded. Feel water with your elbow before bathing or showering. Temperature limiting valves are available, contact a licensed plumber for more information.

To prevent burns:

- Use the lowest operating temperature setting necessary to provide comfortably-hot water.
- If your household has children or elderly or disabled residents, consider using a lower temperature setting.
- Check local codes for maximum water temperature setting allowed when used in nursing homes, schools, day care centers and other public applications.
- Do not leave children, the elderly, or disabled persons unsupervised.
- Do not allow small children to play unsupervised in the bathroom.
- Do not allow anyone to change the water temperature while hot water is running.
- Read all the instructions in this manual carefully before changing the temperature setting.
- Feel the water before using it on children, the elderly, or the disabled.
- If it is necessary to set the water temperature above 125°F (52°C), consider installing a thermostatically-controlled mixing valve or temperature-limiting valve. Contact a licensed plumber or your local plumbing authority for more information.

⚠ DANGER

This water heater's water temperature is set to 120°F (49°C) at the factory for your safety and comfort. Increasing the temperature increases the risk of accidental scalding. Water temperatures at or above 125°F (52°C) can cause instant scalding, severe burns, or death. Before you decide to change the temperature setting, read the following table carefully.

Water Temperature	Time in which a young child can suffer a full thickness (3rd degree) burn
160°F (70°C)	Less than 1 second
140°F (60°C)	1 second
130°F (55°C)	10 seconds
120°F (49°C)	10 minutes
100°F (37°C)	very low scald risk

SAVE THESE INSTRUCTIONS

⚠ DANGER

Indicates a hazardous situation that if not avoided will result in severe injury or death.

⚠ WARNING

Indicates a hazardous situation that if not avoided could result in death or serious injury.

⚠ CAUTION

Indicates a potentially hazardous situation that if not avoided could result in minor or moderate injury.



NOTICE

Indicates information considered important but not hazard-related (such as property damage).

2. About the Water Heater

2.1 Included Items

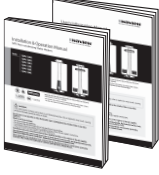
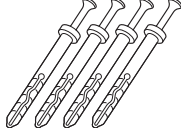
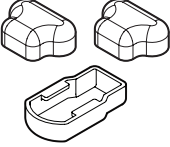



When you open the box, you will find the following items with the water heater. Check the box for each of the following items before installing the water heater.

	
Installation Manual, User's Information Manual	Tapping Screws & Anchors
	
Front Cover Caps (for NSF use)	Remote Controller (Exterior Models Only)

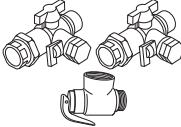
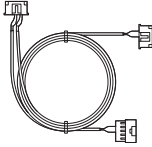
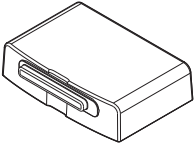
2.2 Accessories

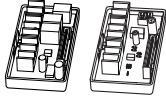
The following optional accessories are available for the water heater:

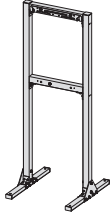
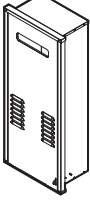
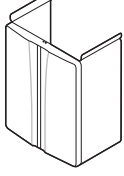
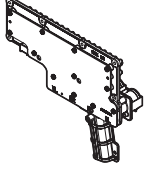
	
Remote Controller	Navien Plumb Easy Valve Set with Pressure Relief Valve
	
Ready-Link Communication Cable	Outdoor Vent Kit (Universal models only)

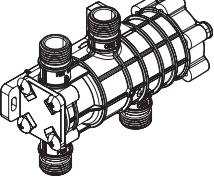
	
External Pump Connector (S Model Only, <150W,1.5A)	Navien HotButton Kit / H2Air Add-on Controller Kit
	
Navi-Link (Wi-Fi Control System)	Ready-Link Rack
	
Recess Box (Exterior Models Only)	Pipe Cover
	
Gas Conversion Kit	HotButton Push Button
	
HotButton Wall Plate	NaviCirc (Recirculation Valve)

2.3 Specifications

The following table lists the specifications for the water heater. Additional specifications about water, gas, electric, and air supplies (venting) appear in the Installation section.

Item		NHW700 Universal/Interior						NHW700 Exterior					
		160SU	160AI	180SU	180AI	199SU	199AI	160SE	160AE	180SE	180AE	199SE	199AE
Heat Capacity (Input)	Natural Gas	10,700-160,000 BTU/H		10,700-180,000 BTU/H		10,700-199,900 BTU/H		10,700-160,000 BTU/H		10,700-180,000 BTU/H		10,700-199,900 BTU/H	
	Propane Gas												
Uniform Energy Factor	UEF (for NG&LP)	0.81	0.81	0.81	0.81	0.81	0.81	0.81	0.81	0.81	0.81	0.81	0.81
Flow Rate (DHW)	45 °F (25 °C) Temp Rise	5.8 GPM (22 L/m)		6.6 GPM (25 L/m)		7.4 GPM (28 L/m)		5.8 GPM (22 L/m)		6.6 GPM (25 L/m)		7.4 GPM (28 L/m)	
	67 °F (36 °C) Temp Rise	4.0 GPM (15 L/m)		4.5 GPM (17 L/m)		5.0 GPM (19 L/m)		4.0 GPM (15 L/m)		4.5 GPM (17 L/m)		5.0 GPM (19 L/m)	
Dimensions	S Model : 14.0 in (W) x 23.0 in (H) x 9.3 in (D), A Model : 17.3 in (W) x 26.5 in (H) x 10.3 in (D)												
Weight (Gross)	55 lbs (25 kg)	68 lbs (31 kg)	60 lbs (27 kg)	72 lbs (33 kg)	60 lbs (27 kg)	72 lbs (33 kg)	55 lbs (25 kg)	71 lbs (32 kg)	60 lbs (27 kg)	75 lbs (34 kg)	60 lbs (27 kg)	75 lbs (34 kg)	
Installation Type	Interior Model: Indoor Wall-Hung Only Universal Model: Indoor Wall-Hung (Vent Kit Optional for Outdoor)						Outdoor Wall-Hung Only						
Venting Type	Forced Draft Direct Vent (Universal/Interior Models Only)												
Ignition	Electronic Ignition												
Water Pressure	15-150 PSI												
Natural Gas Supply Pressure (from source)	3.5 in WC-10.5 in WC												
Propane Gas Supply Pressure (from source)	8 in WC-13 in WC												
Natural Gas Manifold Pressure (Max.-Min.)	2.8 in W.C., 0.7 in W.C		2.3 in W.C., 0.7 in W.C		2.8 in W.C., 0.7 in W.C		3.2 in W.C., 0.8 in W.C		2.6 in W.C., 0.8 in W.C		3.2 in W.C., 0.8 in W.C		
Propane Gas Manifold Pressure (Max.-Min.)	5.8 in W.C., 1.3 in W.C		4.5 in W.C., 1.3 in W.C		5.4 in W.C., 1.3 in W.C		6.1 in W.C., 1.4 in W.C		4.9 in W.C., 1.3 in W.C		6.0 in W.C., 1.3 in W.C		
Minimum Flow Rate	0.26 GPM (1.0 L/m), <0.01 GPM (0.04 L/m) option for "A" Models*												
Activation Flow Rate	0.4 GPM (1.5 L/m)												
Connection Sizes	Cold Water Inlet	$\frac{3}{4}$ in NPT											
	Hot Water Outlet	$\frac{3}{4}$ in NPT											
	Gas Inlet	$\frac{3}{4}$ in NPT											
Power Supply	Main Supply	120V AC, 60Hz											
	Normal	95 W	100 W	115 W	99 W	81 W	96 W						
	Maximum Power Consumption	120W (Max 2A) for Non-Pump Model, 350W (Max 4A) for A Model or S Model with External Pump Connected											
	External Pump	< 150W, 1.5A											
	Fuse	5.0 A											
Materials	Cabinet	Cold Rolled Carbon Steel											
	Heat Exchangers	Stainless Steel											
Safety Devices	Flame Rod, APS, Vent Installation Detector, Ignition Operation Detector, Water Temperature High Limit Switch, Power Surge Fuse												

* Available for NHW-A models configured in an optional ComfortFlow® recirculation mode. Energy consumption will increase when the system is configured for recirculation.

2.4 The Front Panel

The front panel allows you to adjust the water temperature and view the operating status or error codes. Remove the protective sheet from the front panel before using it.

Note The front panel of the exterior model is placed inside the water heater. It is used only for installation and maintenance.

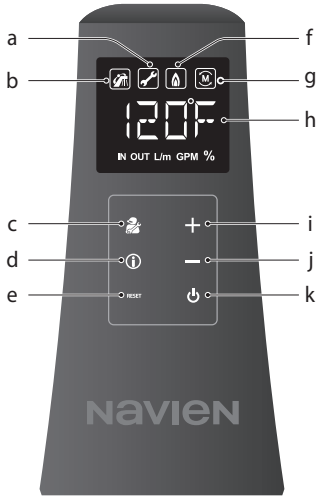

For universal/interior models

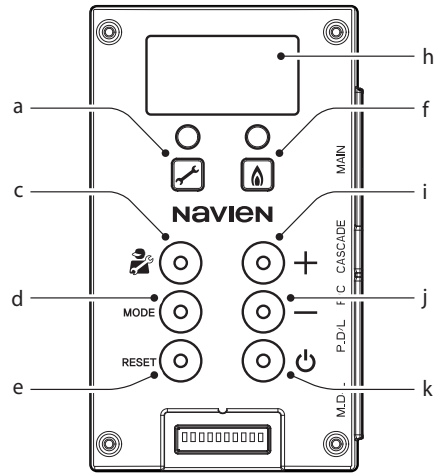

For exterior models



A code will appear on the display



Recirculation Mode



For installers only



Shows basic information



Resets the water heater (When an error occurs)



When the gas burner is on



Cascade operation



Increases the temperature



Decreases the temperature



Turns the water heater on or off

2.5 Components

The following diagram shows the key components of the water heater. Component assembly diagrams and particular parts lists are included in the Appendixes.

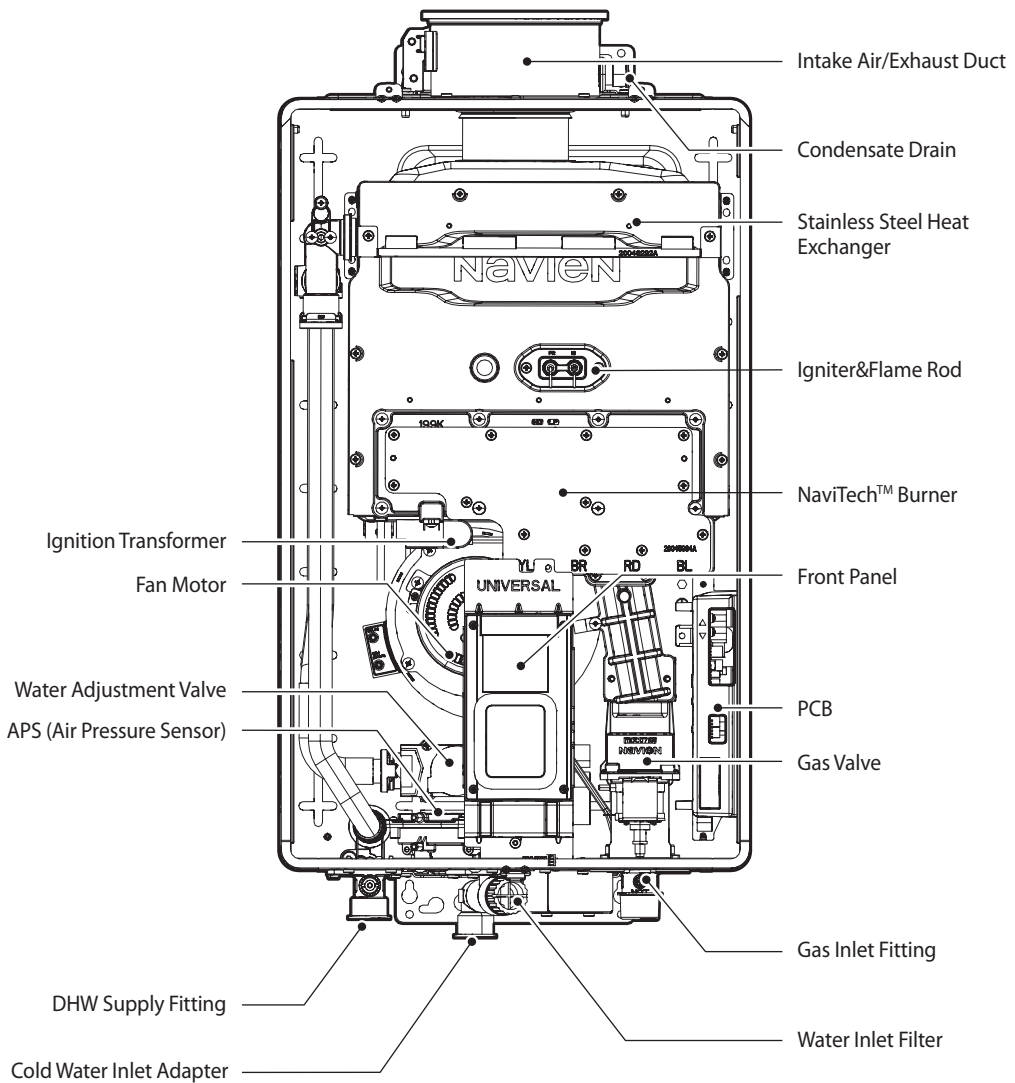

**[NHW700-160SU/180SU/199SU]
For Indoor/Outdoor Use (With Optional Outdoor Vent Kit)**

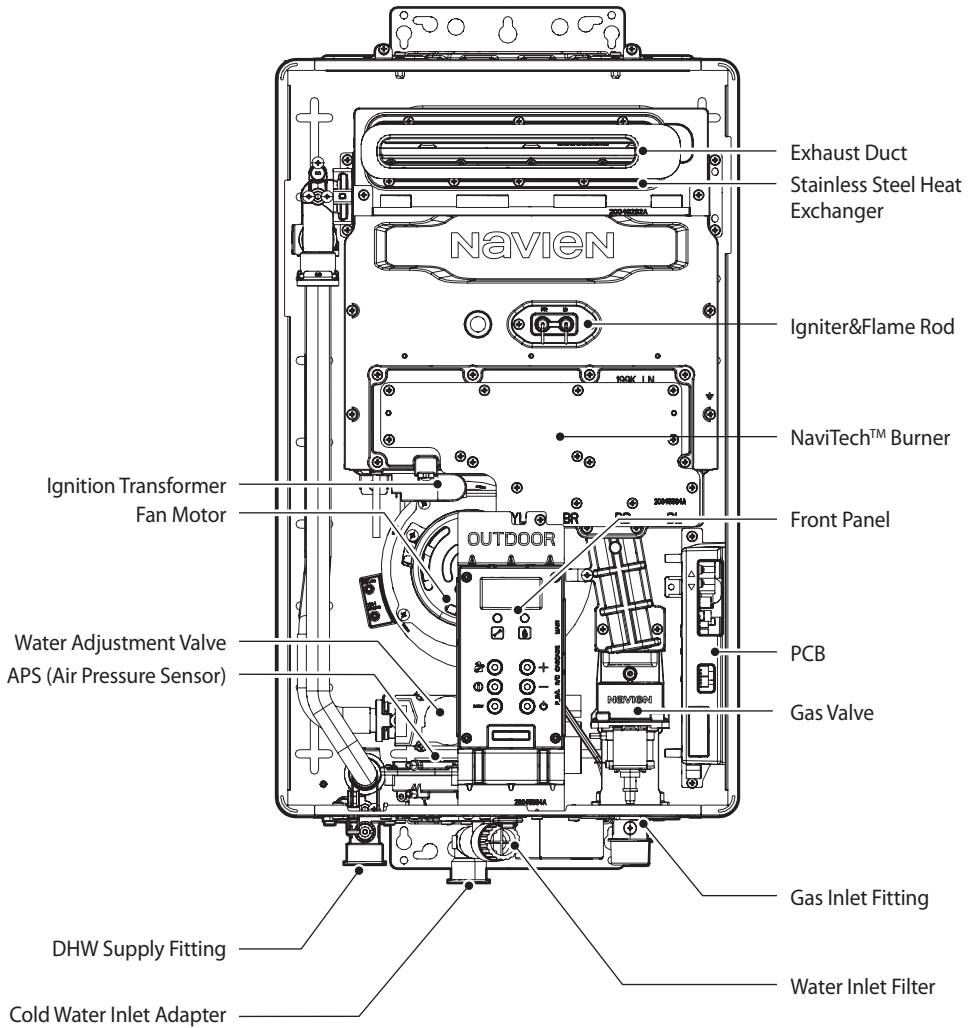

**[NHW700-160SE/180SE/199SE]
For Outdoor Use Only**

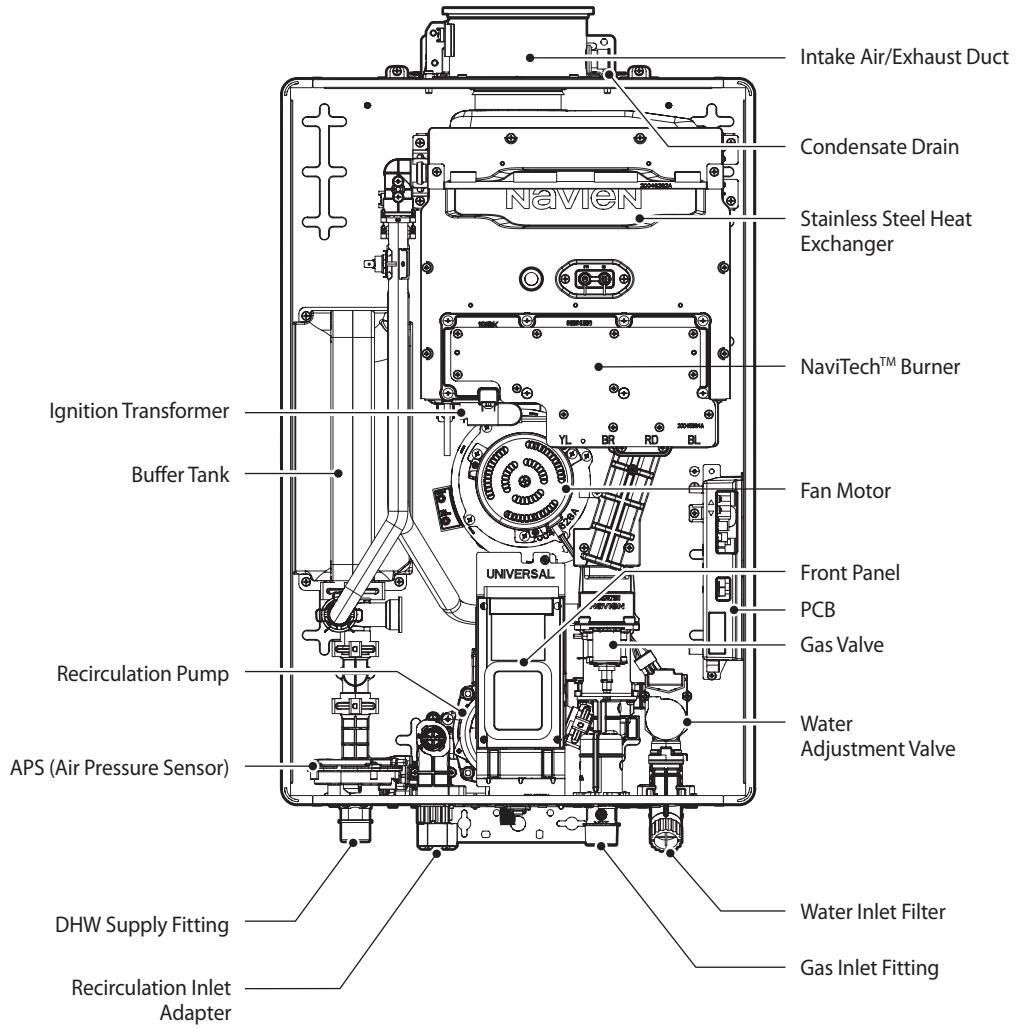

**[NHW700-160AI/180AI/199AI]
For Indoor Use Only**

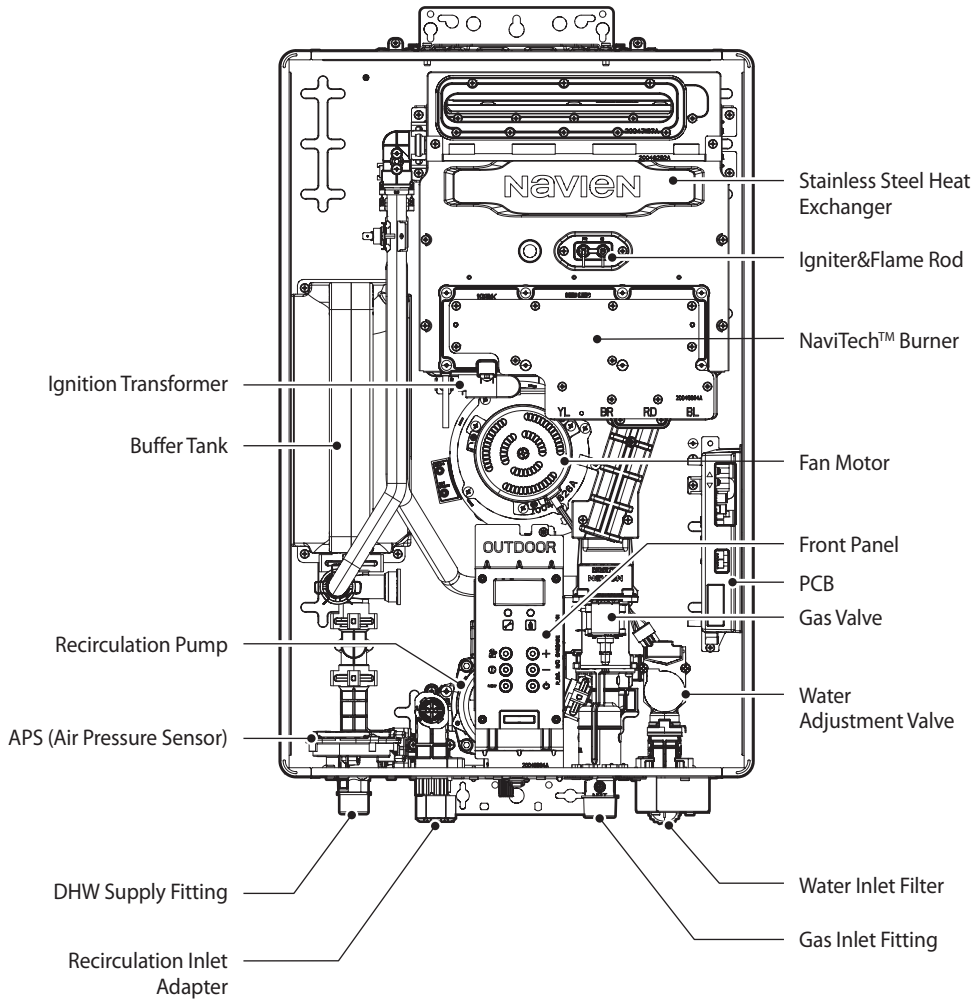

**[NHW700-160AE/180AE/199AE]
For Outdoor Use Only**

2.6 Dimensions

The following diagrams show the dimensions of the water heater and the table lists the supply connections.

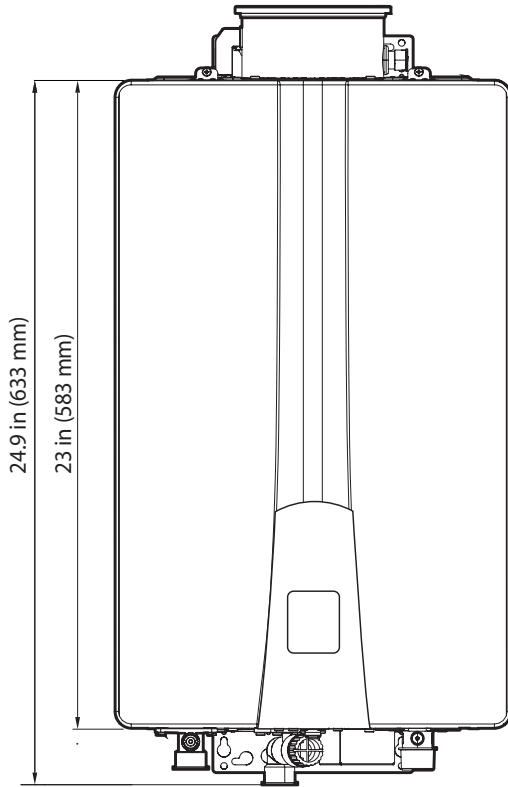

Supply Connections

	Description	Diameter
A	Exhaust Gas Vent	3 in
B	Air Intake	5 in
C	Condensate Drain	$\frac{5}{8}$ in
D	Hot Water Outlet	$\frac{3}{4}$ in
E	Cold Water Inlet	$\frac{3}{4}$ in
F	Gas Inlet	$\frac{3}{4}$ in

Overhead View

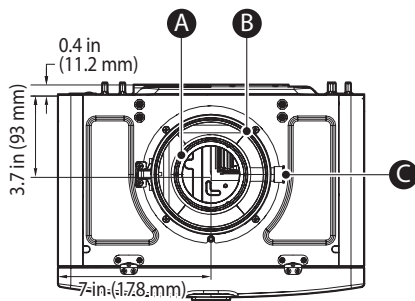

Supply Connections

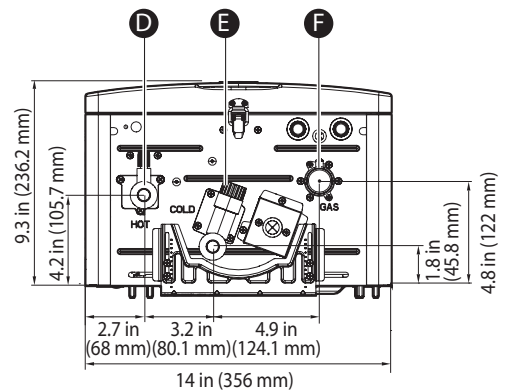

[NHW700-160SU/180SU/199SU]

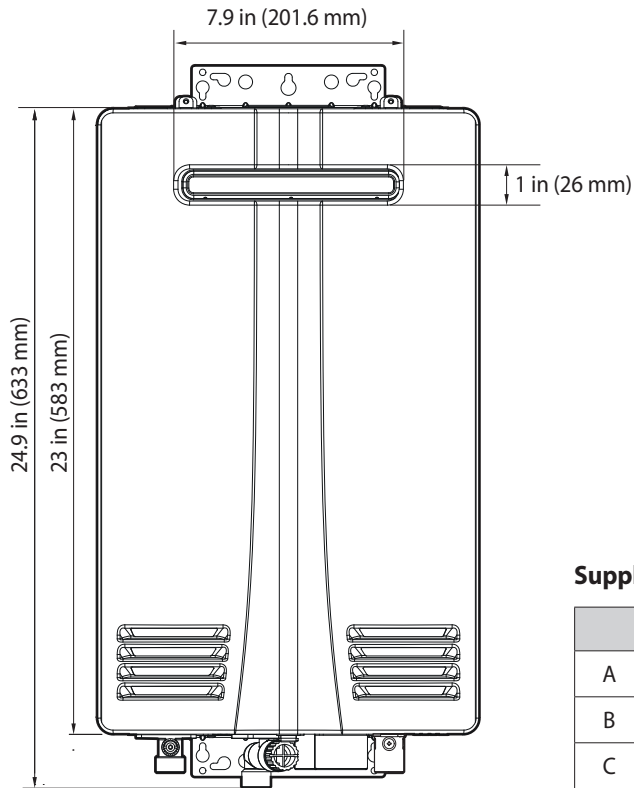

Supply Connections

	Description	Diameter
A	Hot Water Outlet	$\frac{3}{4}$ in
B	Cold Water Inlet	$\frac{3}{4}$ in
C	Gas Inlet	$\frac{3}{4}$ in

Overhead View

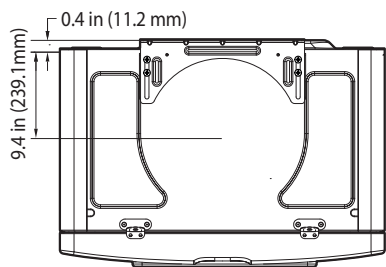

Supply Connections

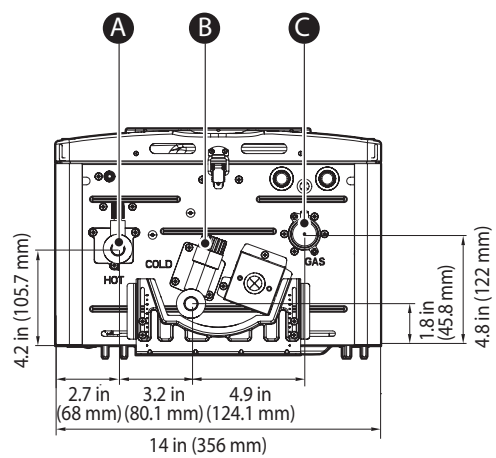

[NHW700-160SE/180SE/199SE]

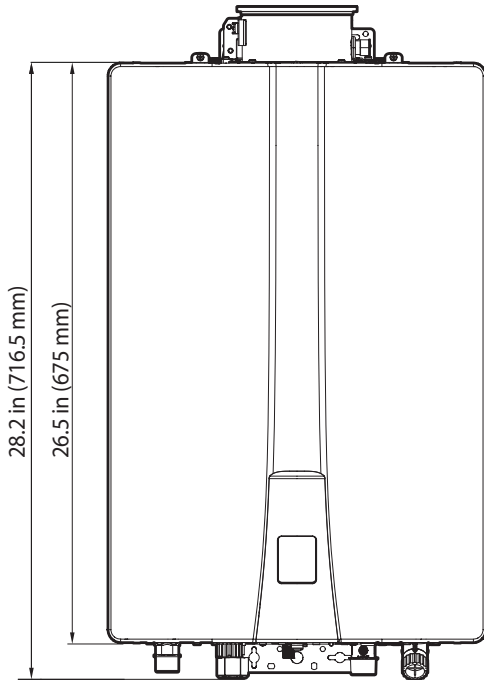

Supply Connections

	Description	Diameter
A	Exhaust Gas Vent	3 in
B	Air Intake	5 in
C	Condensate Drain	$\frac{5}{8}$ in
D	Hot Water Outlet	$\frac{3}{4}$ in
E	Return Inlet	$\frac{3}{4}$ in
F	Gas Inlet	$\frac{3}{4}$ in
G	Cold Water Inlet	$\frac{3}{4}$ in

Overhead View

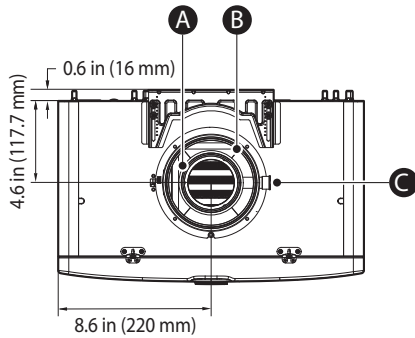

Supply Connections

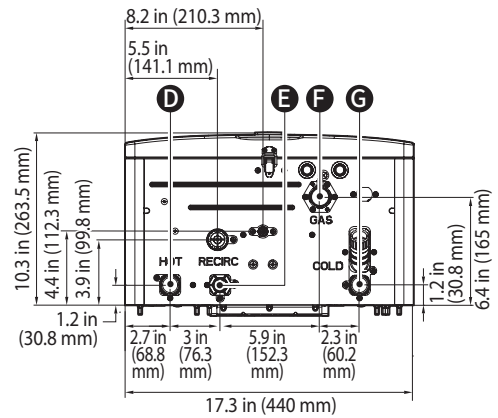

[NHW700-160AI/180AI/199AI]

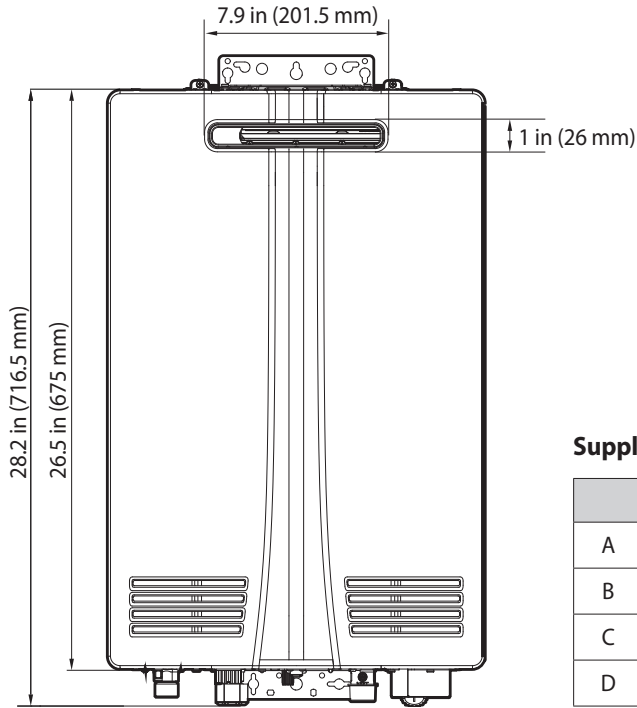

Supply Connections

	Description	Diameter
A	Hot Water Outlet	$\frac{3}{4}$ in
B	Return Inlet	$\frac{3}{4}$ in
C	Gas Inlet	$\frac{3}{4}$ in
D	Cold Water Inlet	$\frac{3}{4}$ in

Overhead View

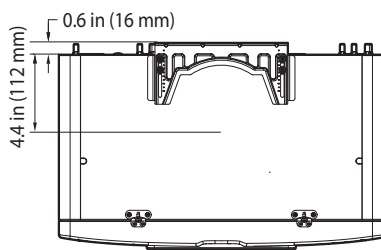

Supply Connections

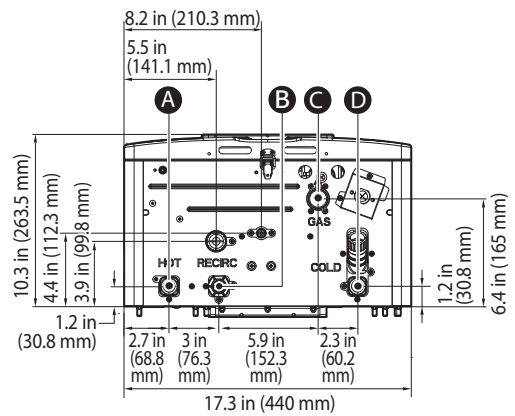

[NHW700-160AE/180AE/199AE]

2.7 Rating Plate

Water heaters come from the factory configured for use with Natural Gas (NG) or Propane Gas (LP). If a gas conversion is required, the optional Gas Conversion Kit must ALWAYS be used. Refer to the Gas Conversion Guide for more information.

Note The Gas Conversion Kit is available through a qualified installer or service agency. If you need assistance, please call a licensed professional or Navien Technical Support at 1-800-519-8794.

WARNING

To prevent death, serious injury or property damage:

Before starting the installation, check the Rating Plate located on the side of the water heater to ensure that the water heater matches the gas type, gas pressure, water pressure, and electrical supply available in the installation location.

If the water heater does not match each of these ratings, do not install the water heater. Using a different gas type will result in abnormal combustion and malfunction of the water heater.

- ONLY a licensed professional should connect the gas supply
- ALWAYS leak test the appliance and the gas connections before operating the appliance.
- This water heater cannot be converted from natural gas to propane without a Navien Propane Gas Conversion Kit. NEVER attempt a field conversion of this water heater without using the Navien Propane Gas Conversion Kit. Doing so will result in dangerous operating conditions and will void the warranty.

Navien Inc. is not liable for any property damage, personal injury or death resulting from improper conversions.

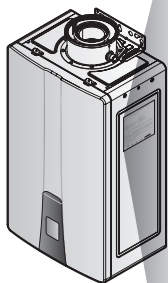

Rating Plate

Direct Vent Automatic Instantaneous Water Heater

For Direct Vent Indoor or Manufactured (Mobile) Home Installations

Navien, Inc.
20 Goodyear, Irvine, CA 92618
Tel: 1-800-519-8794

Model No.

NHW700-199AI-NG

Max. Input Rating

199,900 Btu/h

Recovery Rating

Max. Inlet Gas Pressure

Min. Inlet Gas Pressure

Max. Manifold Pressure

Min. Manifold Pressure

Electrical Rating

Max. Water Pressure

Category of water heater

Type of Gas

Natural Gas

Min. Input Rating

10,700 Btu/h

300 Gallons/Hour

10.5 Inches W.C.

3.5 Inches W.C.

2.8 Inches W.C.

0.7 Inches W.C.

AC 120 Volts 60Hz, less than 4 amperes

150 psi

Category III Certified to ANSI Z21.10.3 - 2019 * CSA 4.3 - 2019

Failure to use the correct gas can cause problems which can result in death, serious injury or property damage. Consult your installation manual for more information.

Suitable for combination water (potable) heating and space heating and not suitable for space heating applications only.

This appliance is certified for use at altitudes up to 4,500 ft (1,370 m) in accordance to the latest CAN/CGA 2.17-High Altitude Installation procedures at normal manifold pressure. This appliance has also been tested up to 10,100 ft (3,078 m). For installations at high altitudes up to 10,100 ft (3,078 m), follow the directions provided in the High Altitude Installations section of the Installation Manual.

This appliance must be installed in accordance with local codes, or in the absence of local codes, the National Fuel Gas Code, ANSI Z223.1/NFPA 54 or the CSA B149.1, Natural Gas and Propane Installation Code.

This appliance must be installed in accordance with the Manufactured Home Construction and Safety Standard, Title 24 CFR, Part 3280 or the Canadian standard CSA Z240 MH Series, Manufactured Homes.

FOR YOUR SAFETY

Do not store or use gasoline or other flammable vapors and liquids in the vicinity of this or any other gas appliances.



3. Installing the Water Heater

3.1 Choosing an Installation Location

When choosing an installation location, you must ensure that the location provides adequate clearance for the water heater, adequate venting and drainage options, and sufficient access to gas, water, and electrical supplies. Carefully consider the following factors when choosing an installation location:

⚠ WARNING

Review the entire installation information in this manual before starting installation. Consider all the requirements for venting, piping, and wiring.

Note

If the water heater is installed in Massachusetts, see “6.8 Requirements for the State of Massachusetts” on page 97.

About Water Quality

Proper maintenance of the water heater is required when water quality does not meet EPA standards. Damage caused by poor water quality is not covered under warranty. The following table shows the maximum contaminant levels allowed, based on the EPA National Secondary Drinking Water Regulations (40 CFR Part 143.3). If you suspect that your water is contaminated in any way, discontinue use of the water heater and contact an authorized technician or licensed professional.

Contaminant	Maximum Allowable Level
Total Hardness	Up to 200 mg/l (12 grains/gallon)
Aluminum	0.05 to 0.2 mg/l
Chloride	Up to 250 mg/l
Copper	Up to 1.0 mg/l
Iron	Up to 0.3 mg/l
Manganese	Up to 0.05 mg/l
pH	6.5 to 8.5
Sulfate	Up to 250 mg/l
Total Dissolved Solids (TDS)	Up to 500 mg/l
Zinc	Up to 5 mg/l
Chlorine	Up to 4 mg/l

If your local water is hard, please review the following recommended treatment and flushing guidelines.

Hardness Level		Treatment Method	Flush Frequency*
Soft	0-4 grains/gal (0-60 mg/L)	None	None
Moderately Hard	4-7 grains/gal (61-120 mg/L)	Water Softener** or Navien	Once/Year
Hard	7-9 grains/gal (121-160 mg/L)	PeakFlow is Recommended	
Very Hard	9-12 grains/gal (161-200 mg/L)	Water Softener** or Navien PeakFlow is HIGHLY Recommended	Residential: Once/Year
Extremely Hard	>12 grains/gal (200 mg/L)	Water Softener** or Navien PeakFlow is Required	

* **Flushing is recommended if a treatment device is not installed.** This procedure should be performed using white vinegar or solutions that are specifically formulated for use on tankless water heaters. See Water Heater Flush Procedures.

**Check local codes for any restrictions on use of water softeners

Water Heater Flushing Procedures

NOTICE

Flushing the Heat Exchanger can be a difficult procedure. Read the following instructions carefully before attempting this procedure. If you are uncertain about any of the steps in the procedure, contact an authorized technician or licensed professional. Keep in mind that improper maintenance can void your warranty.

Refer to “Dimensions” on page 13 for details about part locations.

Before flushing the Heat Exchanger, gather the following items:

- A bucket that is 5 gallons or larger
- Cleaning solution diluted with water
- 3 hoses
- A water circulation pump

To flush the Heat Exchanger:

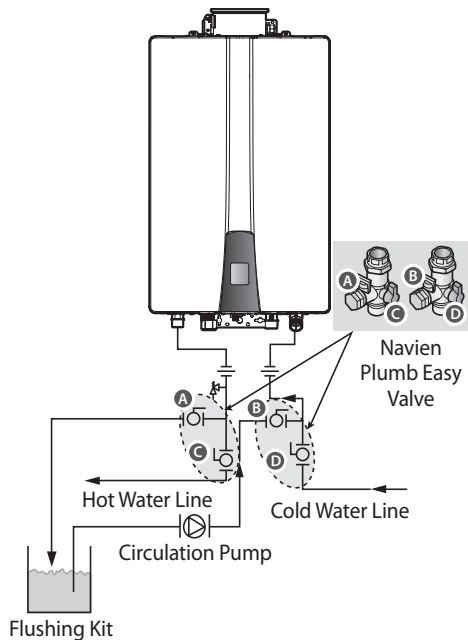

1. Press the Power button on the front panel to turn off the water heater.
2. Disconnect the power supply to the water heater.
3. Close the "C" and "D" valves on the hot and cold water lines.
4. Connect one tube to the "A" valve and place the free end in the bucket.
5. Connect one of the tubes to the circulation pump outlet and the cold water line at the "B" valve.
6. Connect one tube to the Navien Plumb Easy Valve the free end in the bucket.
7. Pour the cleaning solution into the bucket.
8. Open both "A" and "B" valves.
9. Turn on the circulation pump and allow the solution to circulate through the water heater for at least 45 minutes.

10. Rinse the cleaning solution from the water heater:
 - a. Remove the free end of the drain tube from the bucket and place it in the condensate drain or laundry tub (wherever the water heater drains).
 - b. Close the "B" valve and open the "D" valve. Do not open the "C" valve yet.
 - c. Allow water to flow through the water heater for 5 minutes.
 - d. Close the "A" valve and open the "C" valve.
11. Disconnect all tubes.
12. Remove the cold water inlet filter from the water heater and clean out any residue.
13. Reinsert the filter and ensure the filter cap is securely tightened.
14. Reconnect the power supply to the Water Heater.
15. Press the Power button on the front panel to turn on the water heater.

Access to Utilities

- Water – the installation location should be near where the domestic water supply enters the building.
- Gas – the installation location should be near where the gas supply enters the building.
- Electricity – the installation location should be near where the electrical supply enters the building.

Adequate Drainage

This non-condensing water heater may produce condensate within the vent system due to the condition of the installation. Condensate can be drained through the condensate collector. The water heater should be located near a suitable drain and where damage from a possible leak will be minimal.

Note Installing the water heater in a location without a drain will void the warranty and **Navien will not be responsible for water damages that occur as a result.**

The water heater must be located in an area where leakage of the unit or connections will not result in damage to the area adjacent to the appliance or to lower floors of the structure. When such locations cannot be found, installation of an adequately drained drain pan under the water heater is highly recommended. When installing the drain pan, ensure that the installation does not restrict combustion air flow.

Note Navien will not be liable for any damages caused by water leaks.

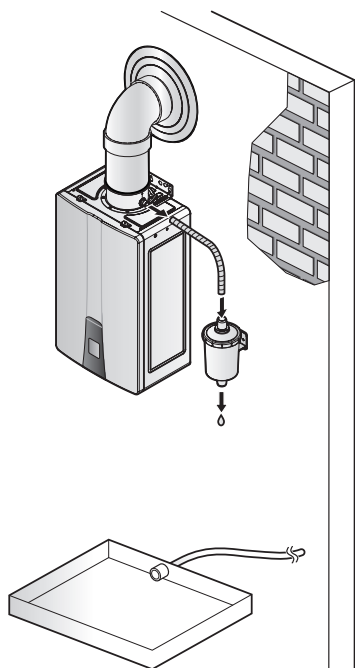

Adequate Venting and Ventilation

Select a location that requires minimal venting. Consider venting restrictions caused by windows, doors, air intakes, gas meters, foliage, and other buildings. For more information about venting, refer to “3.5 Venting the Water Heater (Universal/Interior Models Only)” on page 43.

⚠ WARNING

Improper venting of the water heater can result in excessive levels of carbon monoxide, which can lead to severe personal injury or death. **This water heater must be vented in accordance with the “Venting of Equipment” section of the latest edition of the ANSI Z223.1/NFPA 54 Natural Fuel Gas Code in the USA, as well as all applicable local building codes and regulations.** Follow all instructions and guidelines when venting the water heater. Venting should be performed only by a qualified service agency.

To ensure adequate venting and ventilation, follow these guidelines:

- Maintain proper clearances from any openings in the building.
- Install the water heater with a minimum clearance of 12 in (300 mm) above an exterior grade or as required by local codes.
- Do not enclose the vent termination.
- Install the exhaust vent in an area that is free from obstructions and does not allow the exhaust to accumulate.
- Do not install the water heater where moisture from the exhaust may discolor or damage walls.
- Avoid installing the water heater in bedrooms or any other occupied rooms that are normally kept closed or that are not adequately ventilated.
- Install a carbon monoxide detector in dwelling areas nearby the appliance. Refer to manufacturer’s instructions as well as the Consumer Product Safety Commission (CPSC) and Environmental Protection Agency (EPA) recommendations for proper use of carbon monoxide alarms.

Proximity to Fixtures and Appliances

Install the water heater near fixtures that deliver or use hot water, such as bathroom, kitchen, and laundry room faucets. Select a location that minimizes the water piping required between major fixtures. If the distances are long or if the water heater requires “instant” hot water, we recommend running a recirculation line back to the water heater from the furthest fixture. Insulate as much of the hot water supply and recirculation lines as possible. For more information about the water supply, refer to “3.4 Connecting the Water Supply” on page 29.

Adequate Installation Clearances

Install the water heater in an area that allows for service and maintenance access to utility connections, piping, filters, and traps. Based on the installation location, ensure the following clearances are maintained:

For indoor installation

Clearance from:	to Combustibles	to Non-Combustibles
Top	6 in (152 mm) minimum	2 in (51 mm) minimum
Back	0 in (0 mm) minimum	0 in (0 mm) minimum
Front	6 in (152 mm) minimum	6 in (152 mm) minimum
Sides	2 in (51 mm) minimum	1/2 in (13 mm) minimum
Ground/Bottom	12 in (305 mm) minimum	12 in (305 mm) minimum
Vent	0 in (0 mm) minimum	0 in (0 mm) minimum

For outdoor installation

Clearance from:	to Combustibles	to Non-Combustibles
Top	12 in (305 mm) minimum	2 in (51 mm) minimum
Back	0 in (0 mm) minimum	0 in (0 mm) minimum
Front (panel)	24 in (610 mm) minimum	0 in (0 mm) minimum
Front (exhaust)	24 in (610 mm) minimum	24 in (610 mm) minimum
Sides	6 in (152 mm) minimum	1/8 in (3.2 mm) minimum
Ground/Bottom	12 in (305 mm) minimum	2 in (51 mm) minimum

Clean, Debris and Chemical-Free

Combustion Air

- Do not install the water heater in areas where dust and debris may accumulate or where hair sprays, spray detergents, chlorine, or similar chemicals are used.
- Do not install the water heater in areas where gasoline or other flammables are used or stored.
- Ensure that combustible materials are stored away from the water heater and that hanging laundry or similar items do not obstruct access to the water heater or its venting.

Note

The combustion air must be free of flammable vapors or corrosive chemical fumes. Common corrosive chemical fumes to avoid include fluorocarbons and other halogenated compounds such as Freon, trichloroethylene, perchlorethylene, chlorine, which can be found in refrigerants or solvents. When these chemicals burn, they produce acids that corrode the stainless steel heat exchanger, gaskets, and the flue and vent system.

- In commercial locations, do not install the water heater in areas with greasy fumes or heavy amounts of steam or take measures to prevent fumes and steam from entering the water heater.

High Altitude Installations

This water heater may be installed at elevations up to 10,100 ft (3,078 m) for use with Natural Gas and Propane. Refer to “3.7.2 Setting the Front Panel DIP Switches” on page 56 for the appropriate altitude setting.

Note

Do NOT install this water heater at elevations above 10,100 ft (3,078 m).

Coastal Installations

For installations in sea or marine environments, the salty air can cause corrosion to the water heater. The water should be protected and enclosed to minimize exposure to the corrosive atmosphere. Damage due to a corrosive environment is not covered under warranty.

Operating Temperature

The ambient temperature at the installation location must be above freezing temperature of 32°F (0°C) and below 125°F (52°C).

3.2 Mounting the Water Heater to the Wall

Navien water heaters come with two upper and lower mounting brackets that are pre-drilled at 16 in for easy installation on standard wall studs. If the strength of the wall is insufficient or if the framing is non-standard or uneven, reinforce the area before installing the water heater.

Note

Avoid installation on common walls as the unit will make some operational noises while it is running.

⚠ WARNING

- If the water heater is not properly and securely attached to the wall, it could become dislodged causing the exhaust vent pipe to separate. This can result in carbon monoxide emissions which could cause severe personal injury or death.
- Be careful not to drop the water heater while lifting or handling it to avoid bodily injury or damage to the unit.
- **Do not** rest the water heater on the bottom end after removing it from the shipping carton. Doing so may result in excessive pressure on protruding pipes and cause product damage. If you must put the water heater down, lay it on its back or put it inside the protective shipping base.
- Install the water heater upright in the vertical position. Installation in any other orientation will result in improper water heater operation and property damage, and could result in serious personal injury or death.

⚠ CAUTION

- Ensure that the structure of the installation location is sturdy enough to support the full installed weight of the water heater, including water content of the heat exchanger and related piping.
- The wall must be vertical, and it must be capable of carrying the weight of the water heater.
- Do not mount the water heater to dry wall that has not been reinforced.

To mount the water heater to the wall:

1. Ensure that the strength of the wall is sufficient to support the weight of the water heater.
2. Securely attach the water heater to the wall by affixing the brackets at the top and bottom of the water heater using the provided screws.

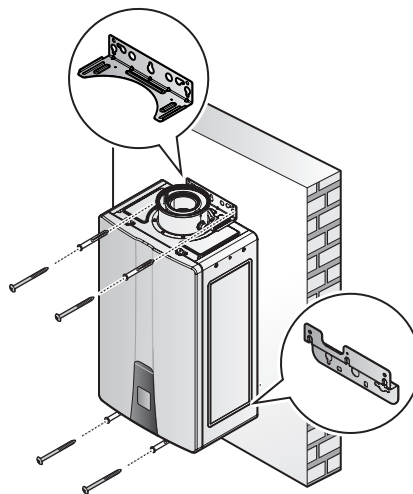

3. Ensure that the water heater is level using a leveling tool.
4. The top and bottom mounting brackets on the water heater are adjustable to provide flexibility in aligning the vent with the unit vent collar.

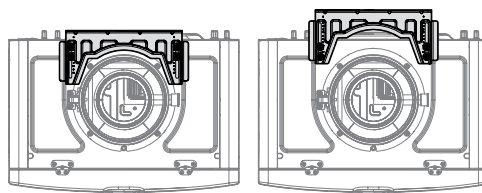

3.3 Connecting the Gas Supply

! WARNING

• **E773 - Improper Gas Type Detection Warning**

This error code activates when the unit detects a discrepancy between the gas type set during installation and the gas type connected to the unit. This function may not detect all abnormal gas connections and that the #1 DIP switch setting must be verified on the Front panel before use.

The unit may take some time to detect the gas type discrepancy as it depends on the gas flow rate and the exhaust outlet temperature. The error code may activate with the correct gas type and gas type setting due to varying measuring tolerances in the unit.

If the error code persists when the DIP switch setting matches the connected gas type, contact Navien Technical Support.

- Using a different gas type will result in abnormal combustion and malfunction of the product.

To prevent death, serious injury or property damage:

- ALWAYS check the Rating Plate located on the side of the product matches the gas type, gas pressure, water pressure, and electrical supply available for the unit.
- CHECK the #1 DIP switch setting on the Front panel matches the type of gas supplied to the unit (OFF for Natural Gas and ON for Propane Gas).

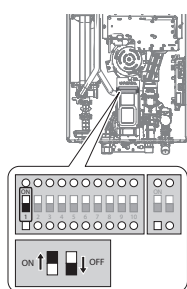

[NHW700 Universal/
Interior Models]

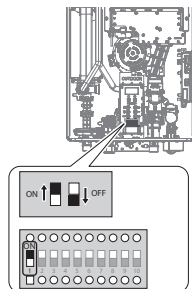

[NHW700 Exterior Models]

Switch	Function	Setting	
1	Gas Type	Natural Gas	1: OFF
		Propane Gas	1: ON

! WARNING

- Before connecting the gas supply, determine the gas type and pressure for the water heater by referring to the rating plate. Use only the same gas type indicated on the rating plate. Using a different gas type will result in abnormal combustion and malfunction of the water heater. Gas supplies should be connected by a licensed professional only.
- To avoid damaging the connectors on the water heater, use two wrenches when tightening pipes to the water heater. Use one wrench to prevent the connector at the water heater from turning, and use the other wrench to tighten the connection. Damaged connectors may result in system leaks.
- Properly support the pipes with hangers. Do not allow the pipes to be supported by the water heater or its accessories.
- Ensure that the gas piping is protected from physical damage and freezing, where required. Failure to follow these instructions could result in gas leakage, and result in fire, explosion, property damage, severe personal injury, or death.
- The appliance and its gas connection must be leak tested before placing the appliance in operation.
- To avoid danger of explosion and fire, do not use flame to check for a gas leak. Perform a bubble test on the joints to check for gas leaks. If a leak exists, bubbles will form at the leaking joint. A gas leak could result in substantial property damage, severe personal injury, or death.
- This water heater cannot be converted from natural gas to propane or vice versa without a Navien gas conversion kit. Do not attempt a field conversion of this water heater without a Navien gas conversion kit installed by a qualified service agency.

Navien recommends connecting the water heater as the first water heater downstream of the gas meter, to ensure a sufficient gas supply.

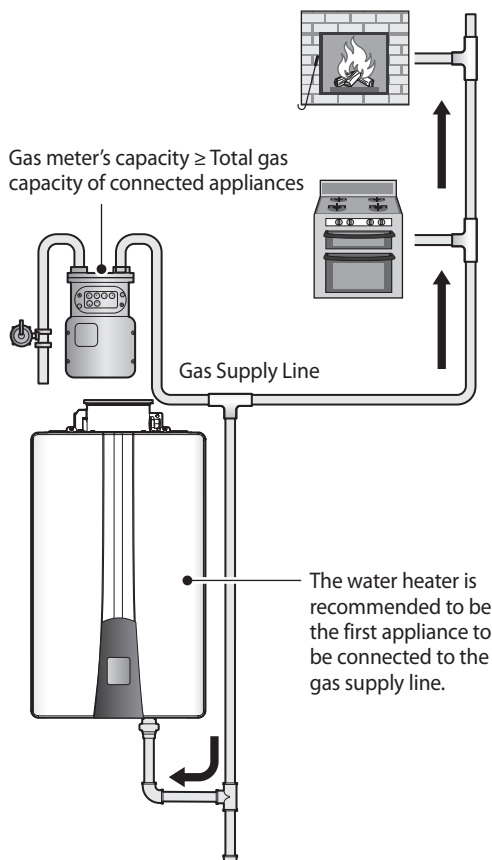

⚠ DANGER

If the connections leak, harmful flue gas may cause personal injury or death. After completing the installation and filling the water heater with water, turn on the water heater and test for leaks using a bubble test kit. After applying the soap solution, bubbles will form on the connection if any leaks exist.

To connect the gas supply:

1. Determine the gas type and pressure for the water heater by referring to the rating plate.
2. Perform a pressure test on the main gas supply line.
3. Purge the gas line of any debris.
4. Determine the proper size and type for the gas line. Refer to the tables that follow.
5. Install certified full port shut-off valves on the gas supply line and water heater.
6. Connect the gas supply line.
7. Test the supply line, all connection points, and the water heater for gas leaks.

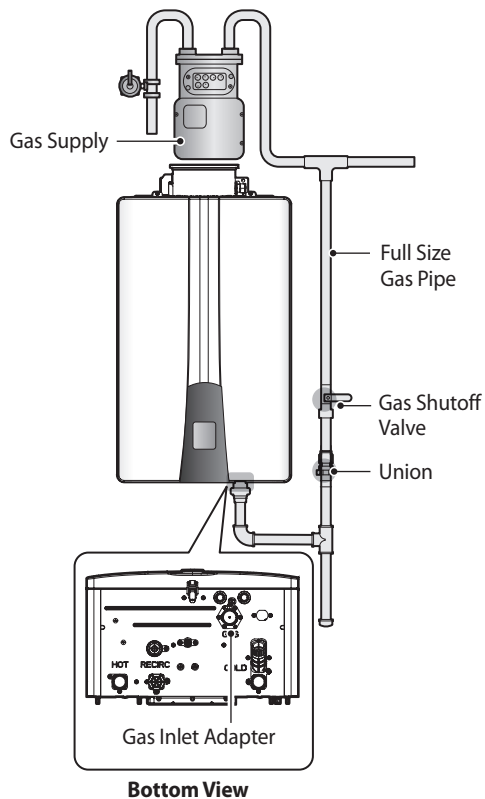

Note

- Tighten the water heater connection valves with care to avoid damage.
- The gas connection fitting on all water heaters is $\frac{3}{4}$ in.
- When using flexible gas lines, ensure that the pipe's inner diameter and connector is sufficient to supply the required BTUs. Also, ensure that the flexible line has no crimps or tight bends in it, as this will restrict gas flow.
- When using rigid pipe, Navien recommends the installation of a union on the gas supply line close to the water heater, to facilitate any future maintenance or service.

NOTICE

Prior to using an excess flow valve (EFV) in the gas line, check the manufacturer's minimum and maximum flow capacity rating. An improperly sized EFV will not allow for a full flow of gas to the water heater and may cause improper operation.

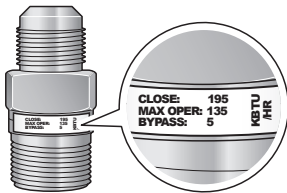

Excess Flow Valve

Typical Propane Gas piping examples:

2 Stage System with Multiple Regulators (Recommended)

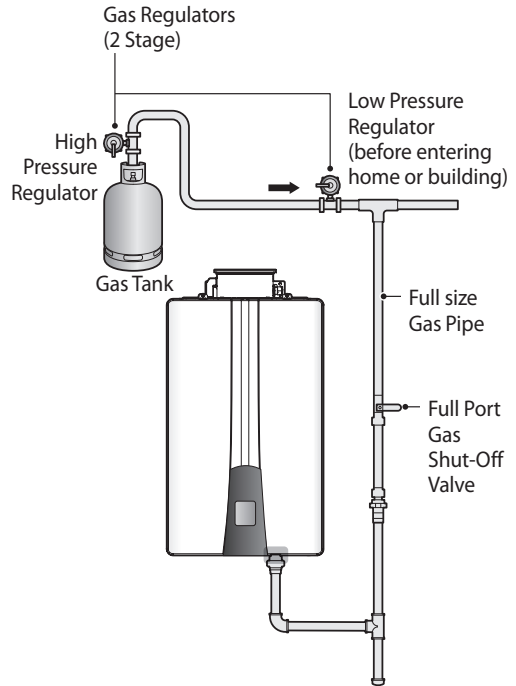

Single Regulator System

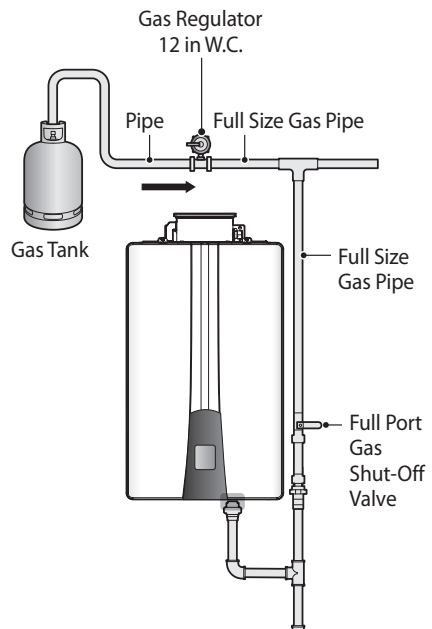

3.3.1 Gas Pipe Sizing Tables (Referenced from NFGC 54 (National Fuel Gas Code))

These tables are for reference only. Please consult the gas pipe manufacturer for actual pipe capacities.

Maximum Natural Gas Delivery Capacity

In cubic feet (ft³) per hour (0.60 specific gravity; 0.5 in WC pressure drop). Contact your gas supplier for BTU/ft³ ratings. Use 1,000 BTU/ft³ for simplified calculations.

Pipe Size	Length (including fittings)										
	10 ft (3 m)	20 ft (6 m)	30 ft (9 m)	40 ft (12 m)	50 ft (15 m)	60 ft (18 m)	70 ft (21 m)	80 ft (24 m)	90 ft (27 m)	100 ft (30 m)	125 ft (38 m)
¾ in	360	247	199	170	151	137	126	117	110	104	92
1 in	678	466	374	320	284	257	237	220	207	195	173
1 ¼ in	1,390	957	768	657	583	528	486	452	424	400	355
1 ½ in	2,090	1,430	1,150	985	873	791	728	677	635	600	532
2 in	4,020	2,760	2,220	1,900	1,680	1,520	1,400	1,300	1,220	1,160	1,020
2 ½ in	6,400	4,400	3,530	3,020	2,680	2,430	2,230	2,080	1,950	1,840	1,630
3 in	11,300	7,780	6,250	5,350	4,740	4,290	3,950	3,670	3,450	3,260	2,890
4 in	23,100	15,900	12,700	10,900	9,660	8,760	8,050	7,490	7,030	6,640	5,890

Maximum Liquefied Propane Delivery Capacity

In thousands of BTU/H (0.5 in WC pressure drop)

Pipe Size	Length (including fittings)												
	10 ft (3 m)	20 ft (6 m)	30 ft (9 m)	40 ft (12 m)	50 ft (15 m)	60 ft (18 m)	80 ft (24 m)	100 ft (30 m)	125 ft (38 m)	150 ft (45 m)	175 ft (53 m)	200 ft (60 m)	250 ft (76 m)
½ in	291	200	160	137	122	110	101	94	89	84	74	67	62
¾ in	608	418	336	287	255	231	212	197	185	175	155	140	129
1 in	1,150	787	632	541	480	434	400	372	349	330	292	265	243
1 ¼ in	2,350	1,620	1,300	1,110	985	892	821	763	716	677	600	543	500
1 ½ in	3,520	2,420	1,940	1,660	1,480	1,340	1,230	1,140	1,070	1,010	899	814	749
2 in	6,790	4,660	3,750	3,210	2,840	2,570	2,370	2,200	2,070	1,950	1,730	1,570	1,440

3.3.2 Measuring the Inlet Gas Pressure

⚠ WARNING

The water heater cannot function properly without sufficient inlet gas pressure. Measuring the inlet gas pressure should be performed by a licensed professional only.

- The inlet gas pressure must be maintained between 3.5 in and 10.5 in WC for natural gas and between 8.0 in and 13 in WC for liquefied propane.
- The appliance and its individual shutoff valve must be disconnected from the gas supply piping system during any pressure testing of that system at test pressures in excess of $\frac{1}{2}$ psi (3.5 kPa). The appliance must be isolated from the gas supply piping system by closing its individual manual shutoff valve during any pressure testing of the gas supply piping system at test pressures equal to or less than $\frac{1}{2}$ psi (3.5 kPa).

Note If gas pressure is out of the acceptable range or an excessive pressure drop is observed, contact the gas supplier or qualified installer to supply proper gas pressure to the unit.

To measure the inlet gas pressure:

1. Shut off the manual gas shut-off valve on the gas supply line.

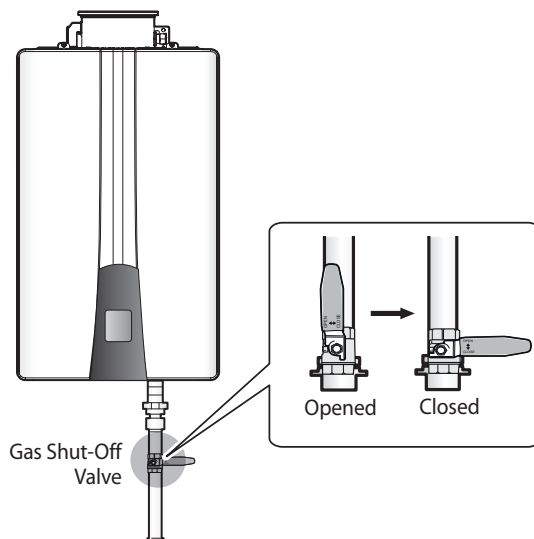

2. Open a hot water faucet. The water heater should turn on and the gas in the gas supply line will be purged.
3. Leave the faucet on until the water heater shuts down due to a lack of gas supply, and then turn off the hot water faucet.
4. Remove the two upper screws from the front cover assembly using a Phillips head screwdriver. Then, release the toggle latch from the bottom of the front cover assembly to gain access to the internal components.

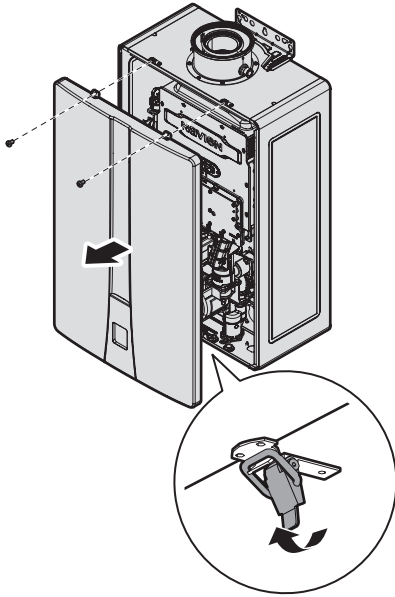

5. Remove the screw from the gas inlet fitting and connect a manometer to the pressure port. Reset the manometer to zero before use.

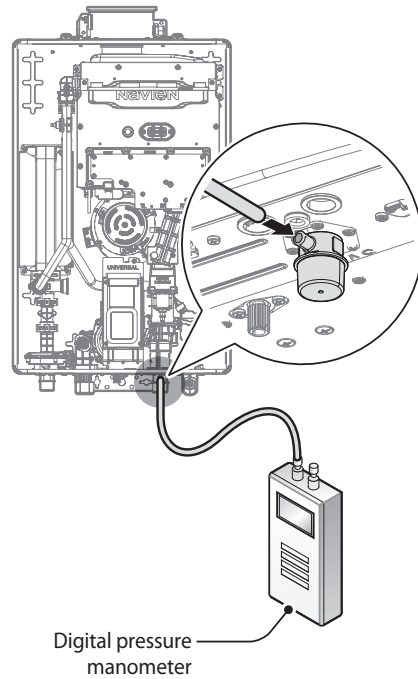

6. Re-open the manual gas shut-off valve and check for leaks.
7. Open multiple fixtures that have high flow rates, such as bathtub and shower faucets, to ramp the water heater up to its maximum firing rate.
8. When the water heater reaches its maximum firing rate, check the inlet gas pressure reading on the manometer. The gas pressure must fall within the ranges specified on page 27.

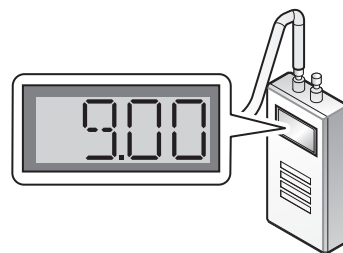

3.4 Connecting the Water Supply

The water fittings on the water heater are $\frac{3}{4}$ in. If the installation site only has $\frac{1}{2}$ in plumbing throughout, it is not necessary to upsize the water lines to $\frac{3}{4}$ in.

When connecting the water supply, follow these guidelines:

- Do not remove the factory installed recirculation inlet cap unless a return line is connected to this fitting. Water leakage will occur if this cap is loose or missing (A models only).
- Use only pipes, fittings, valves, and other components, such as solder, that are approved for use in potable water systems.
- Tighten the water heater connection valves with care to avoid damage.
- We recommend using unions and manual shut-off valves on the cold water inlet and DHW outlet.
- Strive to make the hot water piping system as short as possible, to deliver hot water to the fixtures more quickly.
- To conserve water and energy, insulate all water piping—especially the hot water line. Never cover the drain or pressure relief valve. If the water heater is installed in a closed water supply system, such as one having a backflow preventer in the cold water supply line, means shall be provided to control thermal expansion. Contact the water supplier or local plumbing inspector for information about how to control this situation.
- After installing the water heater, clean the inlet water filter that is located inside the cold water inlet, and then test the water heater for proper flow and inspect for leaks. Instruct the water heater owner that the filter must be cleaned periodically to maintain proper water flow.

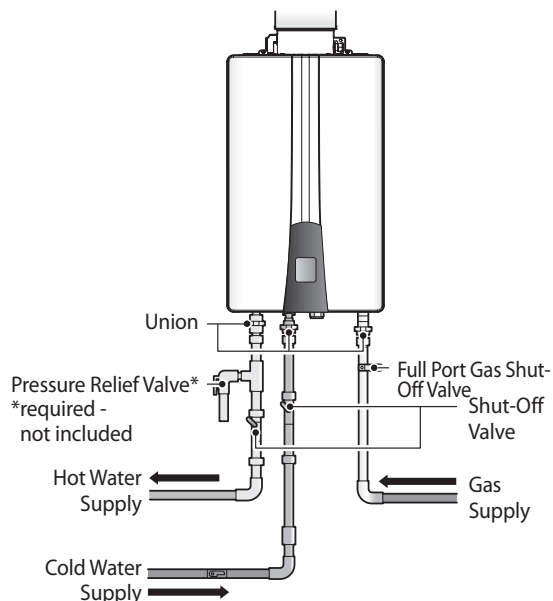

[NHW700-SE/SU Models]

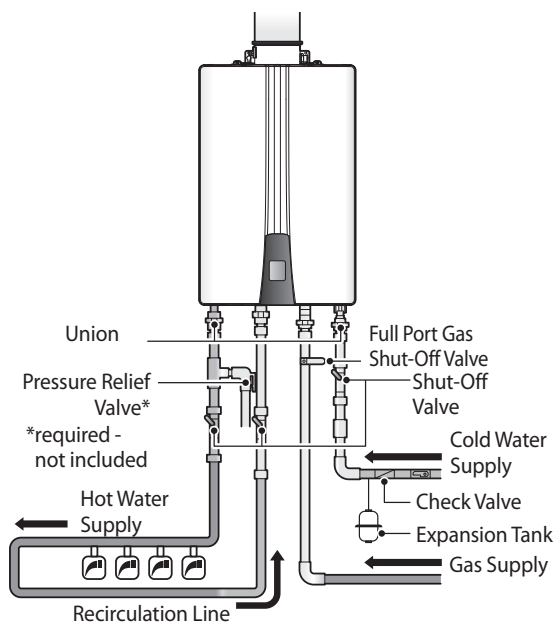

[NHW700-AI/AE Models]

Note

The illustration above provides a typical water piping installation example and is for reference only.

3.4.1 Selecting a Recirculation Mode (AI/AE Models Only)

On all NHW700 AI/AE model water heaters, you can choose from two pre-heating modes: internal recirculation mode or external recirculation mode. To select a recirculation mode, you must adjust the recirculation settings on the front panel and set the position of the 2-way valve inside the water heater.

When the optional ComfortFlow recirculation mode is activated, energy consumption increases because the water heater operates to maintain the water temperature within the circulation loop. You can use the Navien Intelligent Preheating feature, set the weekly timer, or activate the HotButton feature (additional accessories required) to reduce energy consumption.

The recirculation feature of the NHW700 AI/AE models has three performance advantages:

- Lower Minimum Flow Rate is needed to produce hot water.
- Resolves hot/cold/hot stacking issue—the “cold water sandwich” effect.
- Quicker hot water delivery to fixtures, which results in less water wasted.

Note

When using external recirculation mode with the built-in pump, observe the following maximum recirculation pipe lengths including fittings ($\frac{3}{4}$ in. pipe is recommended):

- $\frac{1}{2}$ in. Copper Pipe-100 ft (30 m) of equivalent length
- $\frac{3}{4}$ in. Copper Pipe-500 ft (150 m) of equivalent length

Lengths in excess of these limits will require an external recirculation pump. If PEX is used for the water piping, consult with the pipe and fittings manufacturer for sizing and equivalent pressure drop information.

Internal Recirculation Mode

To use the internal recirculation mode:

1. Connect the water supply.
2. Set the 2-way valve inside the water heater to “INT.”

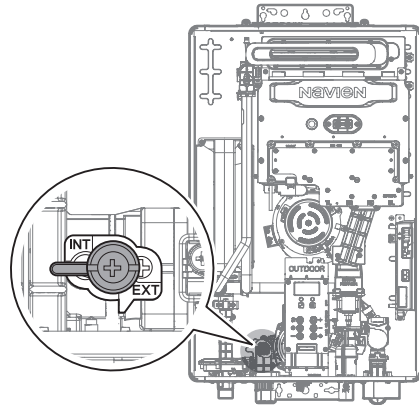

3. Set the front panel DIP switches at the far left (set of ten) to 2-ON.

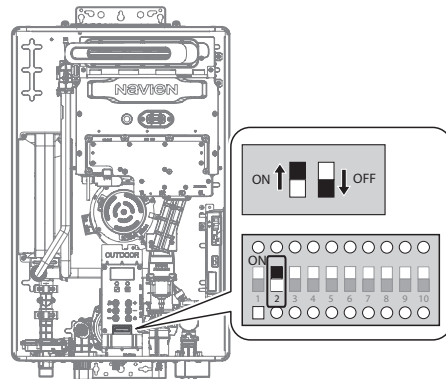

NOTICE

Do NOT remove the pre-installed recirculation cap if the internal recirculation mode is used. Any resulting water leaks may cause property damage.

The following diagram shows the internal recirculation flow for pre-heating:

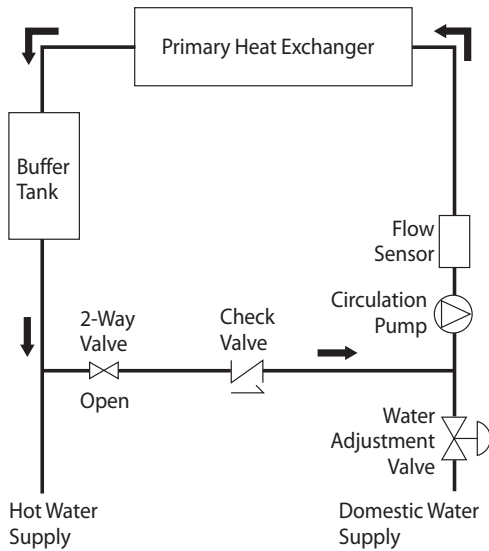

[Internal Recirculation Mode]

External Recirculation Mode

To use the external recirculation mode:

1. Connect the water supply to support recirculation. Refer to the Internal recirculation mode diagram.
2. Set the 2-way valve inside the water heater to "EXT."

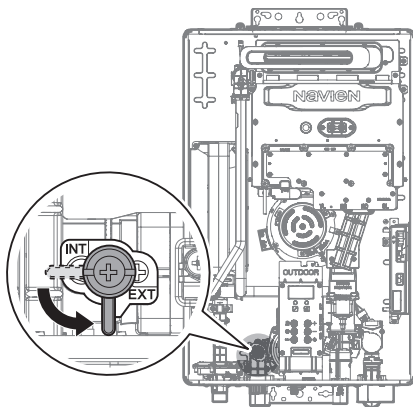

3. Set the front panel DIP switches at the far left (set of ten) to 2-OFF and 3-ON.

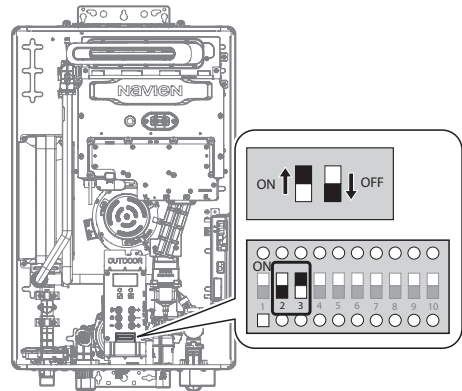

The following diagram shows the external recirculation flow for pre-heating:

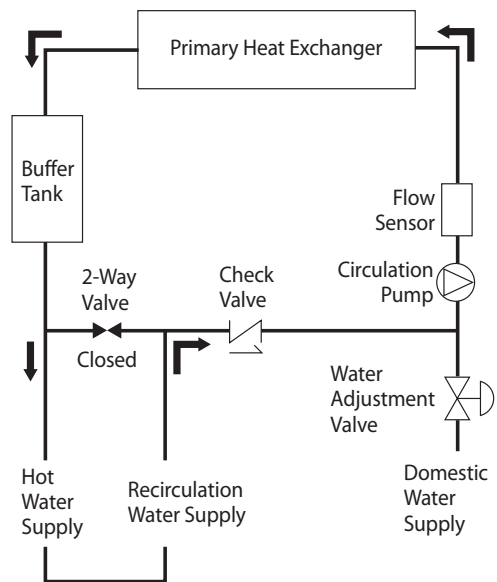

[External Recirculation Mode]

3.4.2 Using the Water Heater for Combination Water Heating and Space Heating

When using the water heater for both water (potable) heating and space heating, follow these guidelines:

- Ensure that all piping and components connected to the water heater are suitable for potable water applications.
- Do not introduce toxic chemicals, such as water treatments, into the potable water.
- On Combi applications, circulators suitable for DHW applications must be used.
- Do not connect the water heater to any heating systems or components that have been previously used with non-potable water heaters.
- If the system requires varying temperatures for water—for example, hotter water for space heating than for other uses—install a mixing valve to temper the water and reduce the potential for scalding.
- Do not use the water heater for space heating only.
- Make sure circulator flow rate through the Water Heater does not exceed 4 GPM.

Note

Do not configure the system for DHW recirculation when it is configured to run an air handler using the H2Air add-on controller. DHW recirculation and Navien H2Air configurations cannot be used at the same time.

3.4.3 External Pump Wire Connection

An external pump may be connected to the water heater for recirculation applications. When selecting a circulator, it shall be sized to maintain a flow of 2-4 GPM through the water heater. Follow the instructions below when connecting the pump wire accessory to the PCB.

⚠ WARNING

Electric Shock Hazard

To prevent death or serious injury or property damage:

- DO NOT remove the front cover unless the power to the water heater is turned off or disconnected.
- ALWAYS check the water heater is turned off before connecting the wire to the PCB.

Note

Configure the desired mode according to the instructions in this manual.

<External Pump Wire (GXXX001319) Specifications>

- Maximum Power Consumption: 150W, 1.5A
 - Length: 6 ft (183 cm)
- ※ When using a pump with larger power requirements than the listed specification above, a relay should be used to ensure proper operation.

1. Disconnect the power supply to the water heater.
2. Remove the two upper screws from the front cover assembly using a Phillips head screwdriver. Then, release the toggle latch from the bottom of the front cover assembly to gain access to the internal components.

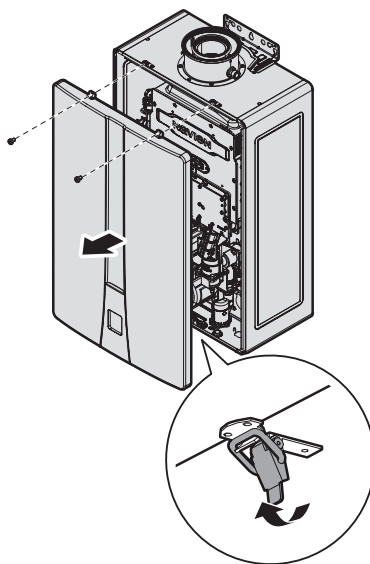

- Remove the 2 screws holding the PCB box in place and remove the PCB box from the system.

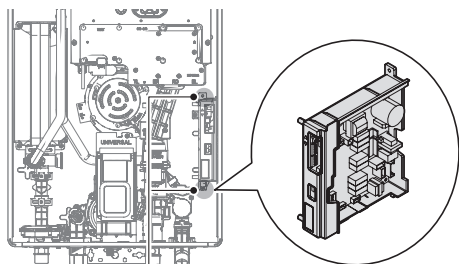

Remove Screws here.

- Connect the external pump wiring connector to the connector socket on the PCB (TB1).

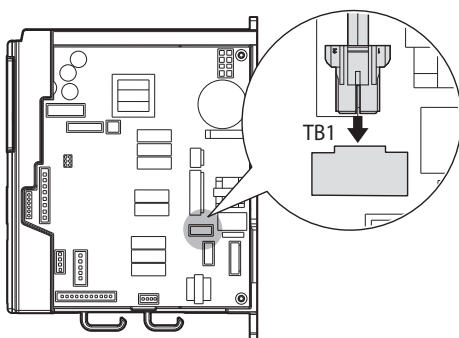

- Put the PCB box back in its original place and secure it using the 2 mounting screws.
- Remove the plastic insulation from the external pump wire with a wire stripper before connecting it to the pump.

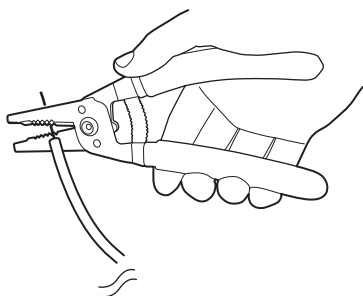

- Connect the External Pump Wire to the proper wires from the pump junction box.

! WARNING

ONLY turn on the water heater after connecting the wire to the external pump to prevent serious injury or death from electric shock.

- Locate the 10-switch DIP (SW1) on the front panel and turn on the proper switches based on the desired recirculation setting (see Recirculation Dipswitch Settings below).

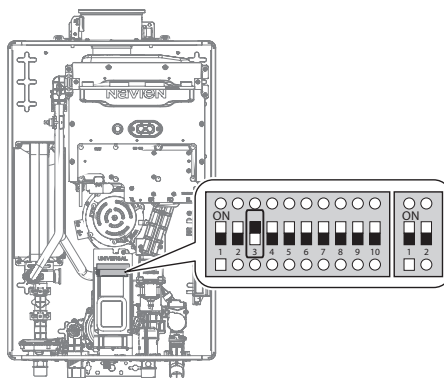

[NHW700 Universal/Interior Models]

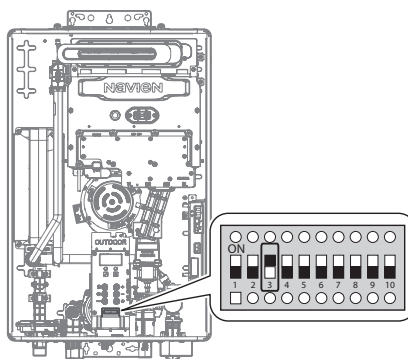

[NHW700 Exterior Models]

9. Turn on the switch beside the front panel.
10. Put the water heater cover back on and secure it with the 4 screws.

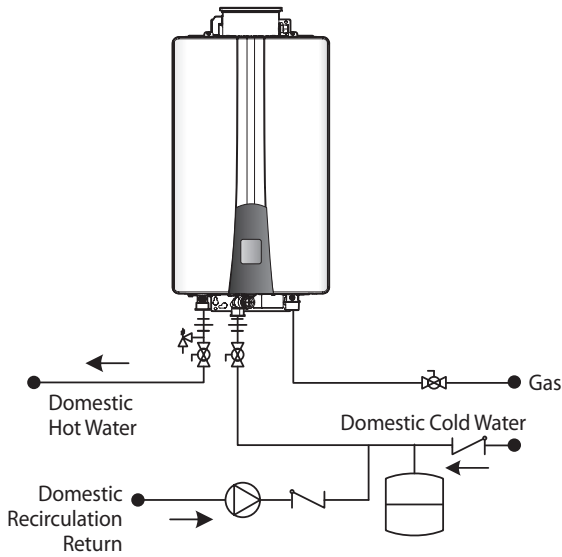

Recirculation Using External Pump Only

3.4.4 Adjusting the Recirculation Parameters

Entering the R&D Information Menu

Follow the instructions below to enter the R&D information menu.

1. On the Front panel, press the Power button to turn off the water heater.
2. Enter the R&D information menu by pressing the Up (+) button three times, the Down (-) button three times, and then the Up (+) button four more times.
3. In the R&D information menu, use the Up (+) or Down (-) buttons to move to 2.PAR (Parameter information mode), and then press the Info button.

No.	Mode	Display
1	Technical Information	1.TEC
2	Parameter Information	2.PAR

4. To return to the previous menu (R&D information menu), press the [Reset] button once.

Items	Name	Description	Display
P12	Pump Cycle Interval	Set the maximum time for pump operation or on-demand operation.	00:00
P14	Pump Sampling Time	Set the pump cycle ON interval.	00:00
P15	Differential OFF Temp	Set the offset temperature to turn off the preheating operation (function disabled with HotButton Kit).	00:00
P17	Thermal Bypass Valve Enable	Activate for use with NaviCirc recirculation valve.	00:00

Pump Cycle Interval Time Settings Mode (P.12)

1. When the P.12 item is displayed on the <PARAMETER INFORMATION MENU MODE> segment, press the [Info] button once to enter the <Preheat Pump Output Time Settings Mode>.
2. Once you enter the mode, enter the parameter values and the item will start to flash.
3. Press the [+] or [-] button in the <Preheat Pump Output Time Settings Mode> to change the value of the PARAMETER.
4. The set item is sent to the controller when you press the [Info] button once or if there is no key input for 10 seconds. If it has been sent properly, the last selected item is set and will start to flash.
5. Press the [Reset] button once to return to the <PARAMETER INFORMATION MENU MODE> (to the previous item of display).
6. If there is no key input for 5 minutes, it is automatically returned to the <PARAMETER INFORMATION MENU MODE> (to the previous item of display).

Items	Description	Display
1-120 (Unit: 1 min), maximum 5 min with optional HotButton Kit	Set the maximum time for pump operation or on-demand operation. (Default: 20 min, maximum 5 min with optional HotButton Kit.) If Cascade is set, the Sub unit will be fixed with the Main unit value.	

Pump Sampling Time Settings Mode (P.14)

Items	Description	Display
1-120 (Unit: 1 min)	Set the pump to periodically cycle ON. (Default: 30 min) If Cascade is set, the Sub unit will be fixed with the Main unit value.	

Differential OFF Temp Settings Mode (P.15)

Items	Description	Display
5 °F (3 °C) – 54 °F(30 °C) [Unit: 1 °F (0.5 °C)]	Set the offset temperature to turn OFF the preheating operation. [Default: 9 °F (5 °C)] If Cascade is set, the Sub unit will be fixed with the Main unit value.	
Not available	Setting is not available with the optional HotButton Kit.	

Intelligent Preheat Settings Mode (p.34)

This mode allows the water heater to learn the user's hot water usage patterns and start preheating prior to an anticipated draw.

Note

- Intelligent preheating starts when remote controller is not connected.
- Intelligent preheating does not function in Cascade.

Items	Description	Display
1. OFF	Intelligent preheat Off	
2. ON	Intelligent preheat On	
Not available	Setting not available (Cascade)	

3.4.5 System Application – External Recirculation

External Recirculation

The following diagram shows the recirculation system's basic operation of an NHW700 water heater system with the dedicated return line.

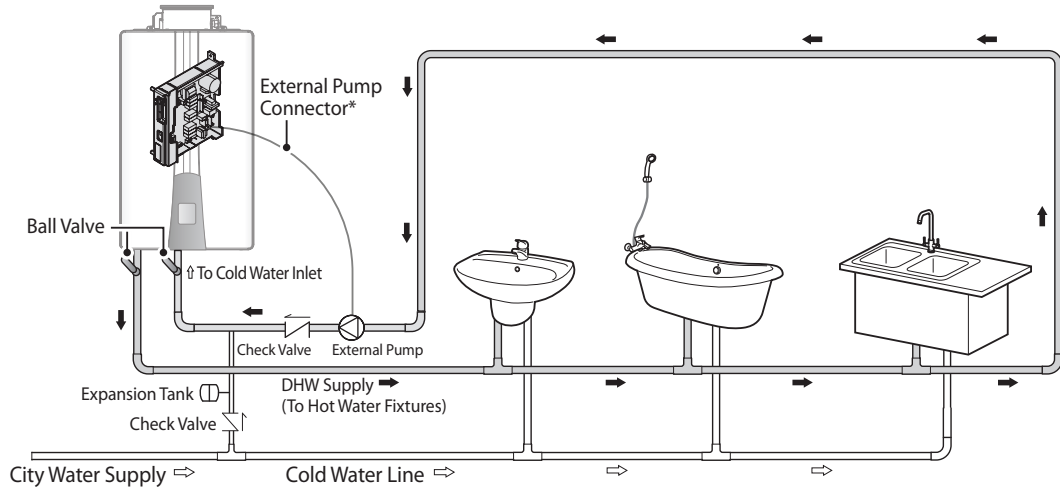

[NHW700-SE/SU Models]

*The external pump connector is not included with the water heater but it is available for purchase. For more information about connecting the external pump to the water heater, refer to “3.4.3 External Pump Wire Connection” on page 32.

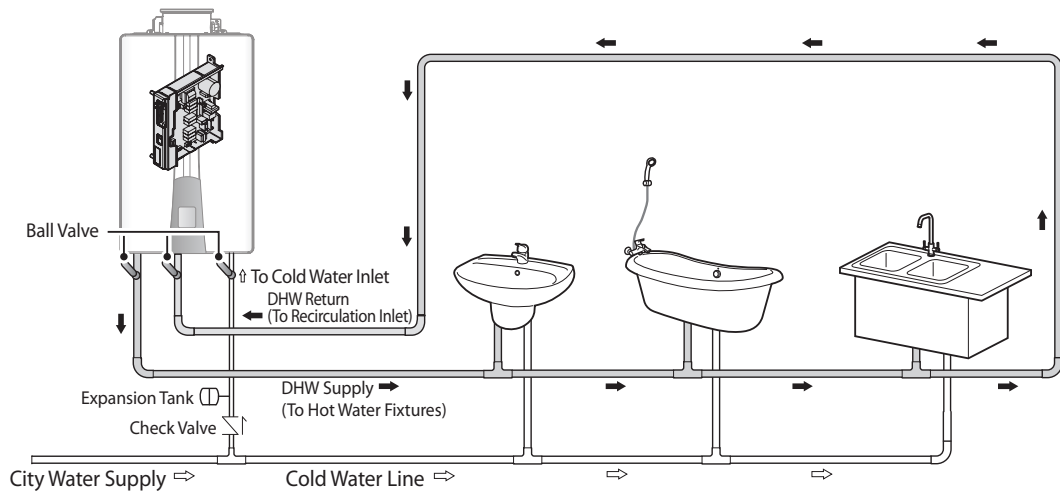

[NHW700-AI/AE Models]

External Recirculation with Hotbutton (Optional)

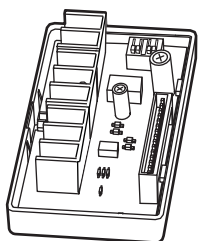

The Navien HotButton kit is an add-on input board for the water heater. It adds signal input functions to the water heater for more efficient DHW hot water recirculation functionality.

With the HotButton kit, DHW recirculation is carried out exactly when the actual demands arise. This prevents energy loss caused by unnecessary operation of the burner and pump throughout the day.

The HotButton kit can receive signals from multiple push buttons installed in various areas and performs optimal DHW recirculation only when there is a demand for hot water.

The following diagram shows the basic operation of an NHW700 water heater recirculation system with the HotButton Kit.

NOTICE

The Navien HotButton can be used ONLY with a water heater system configured for DHW recirculation.

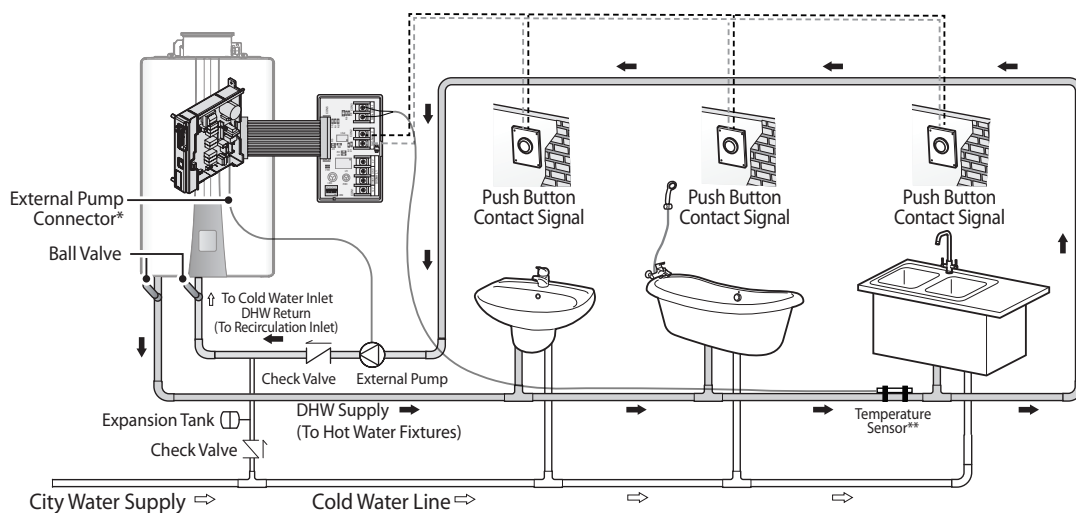

[NHW700-SE/SU Models]

*The external pump connector is not included with the water heater but it is available for purchase. For more information about connecting the external pump to the water heater, refer to "3.4.3 External Pump Wire Connection" on page 32.

** When the optional temperature sensor is installed, it must be insulated. The sensor wire may be extended by up to 100 ft (30 m) using 22AWG wire.

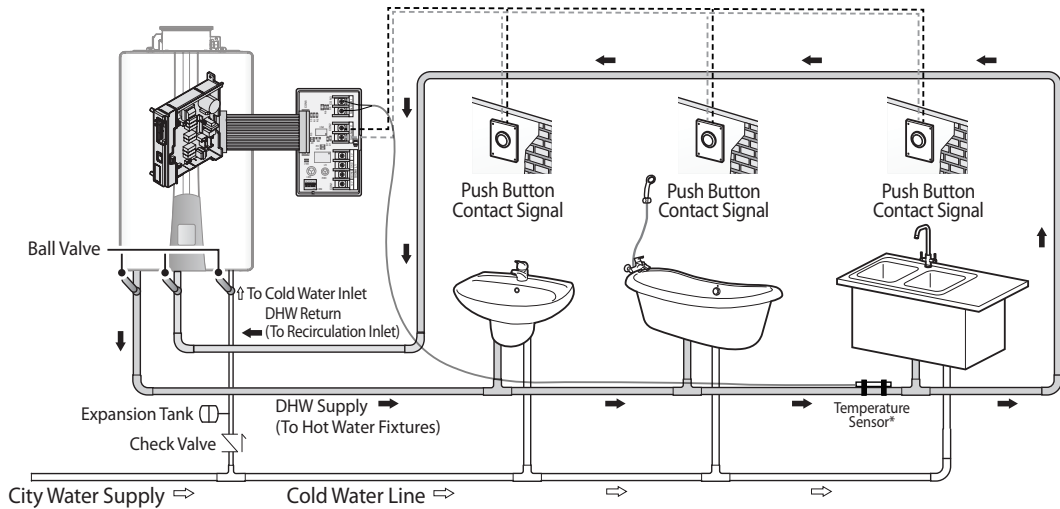

[NHW700-AI/AE Models]

*When the optional temperature sensor is installed, it must be insulated. The sensor wire may be extended by up to 100 ft (30 m) using 22AWG wire.

External Recirculation with HotButton and NaviCirc (Optional)

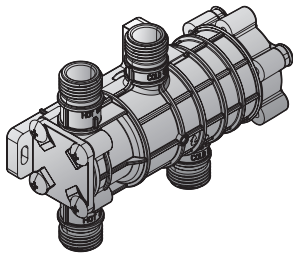

NaviCirc is a circulation device for standard domestic hot water lines without a recirculation system. It allows domestic hot water lines and domestic cold water lines to connect to the NaviCirc and preheat hot water lines by circulating hot and cold water through the NaviCirc. This prevents hot water loss and heating time loss.

To prevent too much hot water from flowing into the cold water line, the NaviCirc includes a feature that automatically blocks circulation when reaching a temperature of approximately 95°F (35°C).

The following diagram shows the basic operation of an NHW700 Series water heater recirculation system with the NaviCirc.

Note

- Install the NaviCirc to the faucet farthest from the water heater. If installed in close proximity to the water heater, faucet pipes far away may not be properly heated.
- For details, refer to the manual provided with the NaviCirc kit.

The following diagram shows the basic operation of an NHW700 Series water heater recirculation system with the NaviCirc and HotButton.

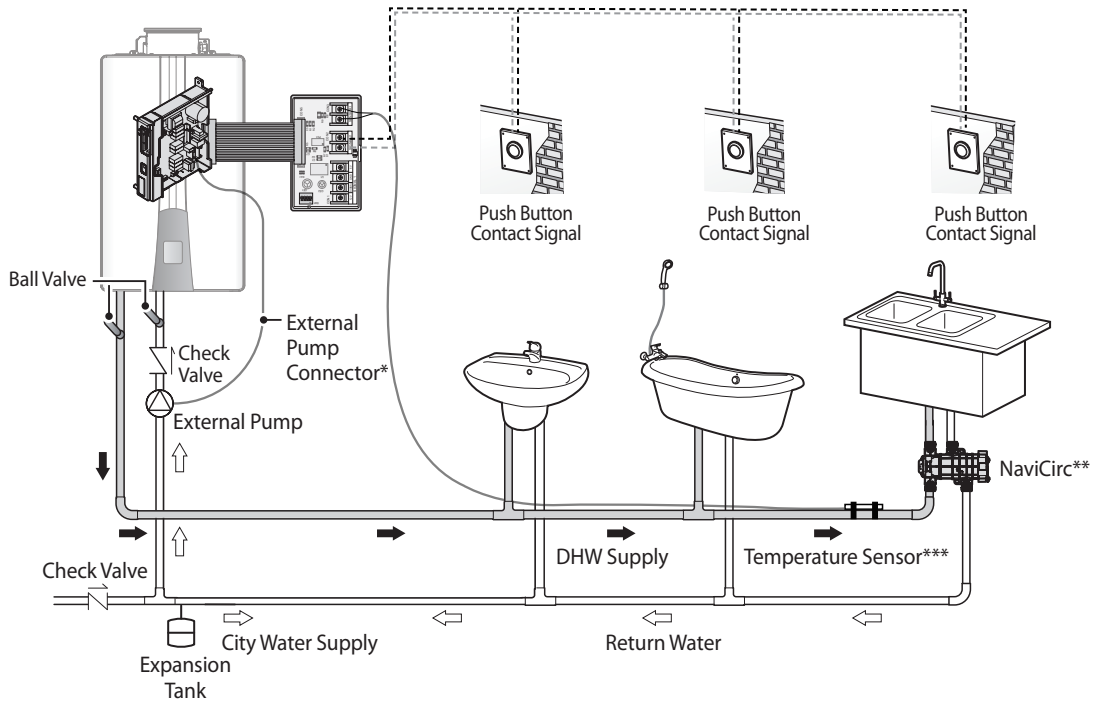

[NHW700-SE/SU Models]

*The external pump connector is not included with the water heater but it is available for purchase. For more information about connecting the external pump to the water heater, refer to “3.4.3 External Pump Wire Connection” on page 32.

** The NaviCirc recirculation valve and the temperature sensor are not included with the water heater but they are available for purchase.

*** When the optional temperature sensor is installed, it must be insulated. The sensor wire may be extended by up to 100 ft (30 m) using 22AWG wire.

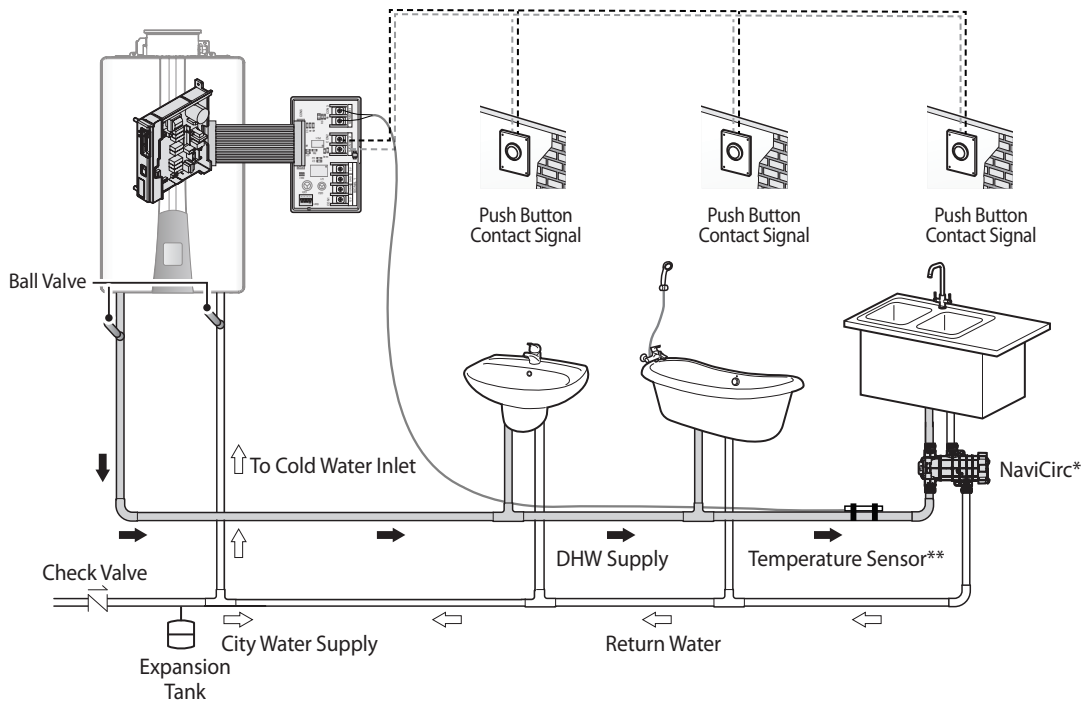

[NHW700-AI/AE Models]

*The NaviCirc recirculation valve and the temperature sensor are not included with the water heater but they are available for purchase.

** When the optional temperature sensor is installed, it must be insulated. The sensor wire may be extended by up to 100 ft (30 m) using 22AWG wire.

External Recirculation with HotButton and Dedicated Return Line

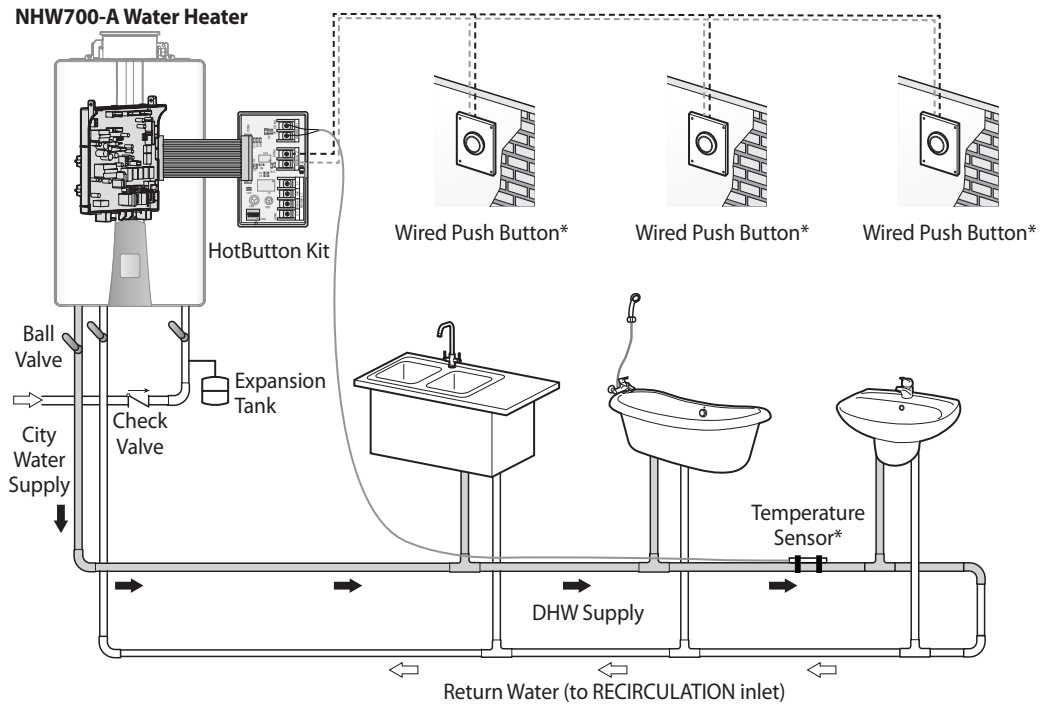

*The push buttons and the temperature sensor are not included with the water heater but are available for purchase.

3.4.6 Connecting a Pressure Relief Valve

⚠ WARNING

Improper installation of the pressure relief valve may result in property damage, personal injury, or death. Follow all instructions and guidelines when installing the pressure relief valve. The valve should be installed only by a licensed professional.

To complete the installation of the water heater, you must install an approved $\frac{3}{4}$ in, maximum 150 PSI pressure relief valve on the hot water outlet. The water heater has a built-in high temperature shut off switch, so install a "pressure only" relief valve. This valve is not supplied, but is required. The following examples are approved for use with the water heater:

- Wilkins P-1000A (Zurn Industries)
- Conbraco 17-402-04
- Watts Industries 3L(M7)
- Cash Acme FWL-2, $\frac{3}{4}$ in

The pressure relief valve should be placed as close to the water heater as possible. No other valve should be placed between the pressure relief valve and the water heater.

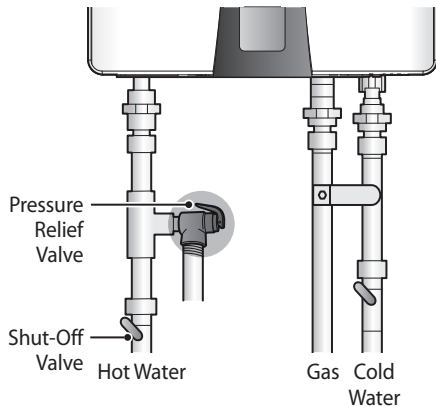

⚠ WARNING

To avoid water damage or scalding, direct the discharge line to a safe place for disposal.

When installing the valve, follow these guidelines:

- Ensure that the discharge capacity of the pressure relief valve is equal to or greater than the maximum pressure rating of the water heater.
- Ensure that the maximum BTU/H rating on the pressure relief valve is equal to or greater than the maximum input BTU/H rating of the water heater.
- Direct the discharge piping of the pressure relief valve so that hot water will not splash on anyone or any nearby equipment.
- Attach the discharge line to the pressure relief valve and run the end of the line to within 6-12 in (150-300 mm) of the floor drain making discharge clearly visible.
- Ensure that the discharge line will allow free and complete drainage without restriction. Do not install a reducing coupling or other restriction on the discharge line.
- Do not direct the discharge line to a location where freezing could occur.
- Ensure that the discharge line is not plugged or obstructed.
- After filling and pressurizing the system, test the relief valve operation by lifting the lever. If the valve fails to operate correctly, immediately replace the relief valve.
- If the relief valve discharges periodically, this may be due to thermal expansion in a closed water supply system. Contact the water supplier or local plumbing inspector on how to correct this situation. Do not plug the relief valve.

⚠ WARNING

- To avoid potential property damage or personal injury, check the pressure relief valve at least once every three years by manually operating the valve to ensure proper operation.
- Before manually operating the valve, check the discharge line and make sure that the hot discharge water will not cause personal or property damages. Contact with the discharge water may result in severe personal injury.

3.5 Venting the Water Heater (Universal/Interior Models Only)

DANGER

This appliance is certified as a Category III appliance and requires a special venting system. The vent system operates with a positive pressure in the pipe.

To prevent serious injury or death:

- ALWAYS vent exhaust gases directly outdoors using the vent materials and following these instructions.
- DO NOT connect vent connectors serving appliances vented by natural draft into any portion of mechanical draft systems operating under positive pressure.

WARNING

Improper venting of the water heater can result in excessive levels of carbon monoxide and can lead to serious injury or death.

This water heater must be vented in accordance with the "Venting of Equipment" section of the latest edition of the ANSI Z223.1/NFPA 54 Natural Fuel Gas Code in the USA and/or the "Venting systems and air supply for water heaters" section of the latest version of the CAN/CGA B149.1 Natural Gas and Propane Installation Code in Canada, as well as all applicable local building codes and regulations.

To prevent serious injury or death:

- ONLY licensed professionals should install venting.
- ALWAYS follow all regulations, codes, and instructions when venting the water heater.
- ALWAYS seal the venting system gastight to prevent flue gas leakage and carbon monoxide emissions.
- The building owner is responsible to maintain the exhaust and intake terminations free of snow, ice, or other potential blockages, as well as scheduling routine maintenance.

The water heater is a Category III appliance designed for use with a concentric venting system, which uses one pipe with two ducts for combustion air and exhaust air, respectively.

The water heater must be properly vented to ensure a constant supply of clean intake air and to ensure that exhaust air is properly removed from living areas. The vent system must vent directly to the outside of the building and use outside air for combustion. When venting the water heater, it shall be installed in accordance with the water heater manufacturer's instructions. Review the following guidelines:

- Do not install the water heater in areas with contaminated air (containing a high level of dust, sawdust, sand, flour, aerosols, or any other such airborne contaminants), as contaminants can cause operational problems. The warranty does not cover damage caused by contaminants in the installation area.
- Do not use PVC, CPVC, ABS, or any galvanized material to vent the water heater.
- Do not combine any vent components or parts from different manufacturers.
- Do not reduce the vent diameter.
- Do not connect the venting system with an existing vent or chimney.
- Do not vent in common with the vent pipe of any other water heater or appliance.
- For best results, keep the venting system as short and straight as possible.
- Locate the water heater as close as possible to the vent termination.
- For horizontal runs, slope the horizontal section upward toward the vent termination at a rate of $\frac{1}{4}$ in per foot (2 % slope) when using a condensate collector. Slope the horizontal section downward toward the vent termination when not using a condensate collector. Refer to the manufacturer's instructions for using a condensate collector.
- Create an airtight seal at the joint in the vent pipe that leads from the water heater collar to the vent termination by fully inserting the vent pipe into the water heater collar. The vent pipe must be inserted 1.3 in (34 mm) into the water heater collar. Once fully inserted, mark the vent pipe with a permanent marker directly above the water heater collar to observe any displacement during the installation process. If displaced, then readjust the vent pipe to ensure full insertion into the water heater collar.

⚠ WARNING

- The vent piece connected to the water heater must be secured by one self-tapping screw.

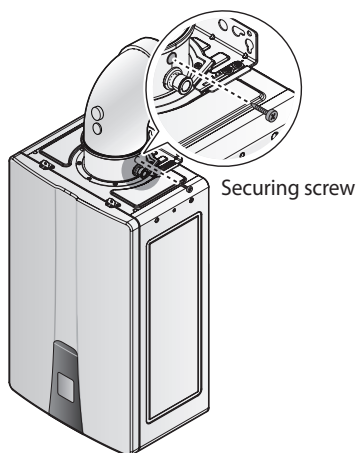

- Each pipe must be secured using two self-tapping screws when connecting extension pipes or the elbow to the vent piece. When inserting the screws, ensure that you place the screws at a point 1.0 in (25 mm) from the vent pipe end to avoid damaging the vent pipe gasket.

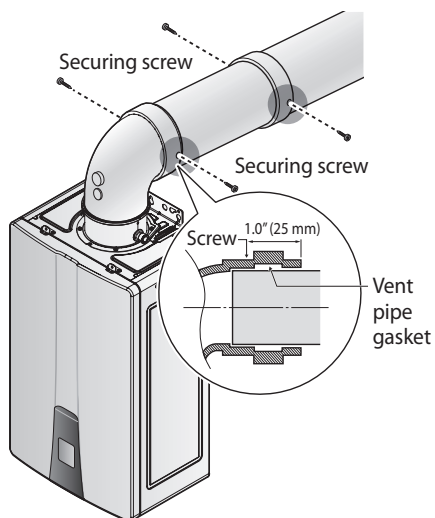

- Ensure that the self-tapping screws are used to secure the pipes together as well as the pipes to the water heater. Failure to do so may result in the pipes being loose and thereby cause property damage, personal injury, or death.

- Do not store hazardous or flammable substances near the vent termination.
- If this water heater will be installed in areas where snow is known to accumulate, protect the vent termination from blockage.
- Ensure that the vent termination is at least 12 in (305 mm) above the highest anticipated snow line, or as required by local codes, whichever is greater.
- Vent pipes must be supported with hangers at least every 4 ft (1.2 m) horizontally and every 6 ft (1.83 m) vertically.

3.5.1 About the Vent Installation Detector

The NHW700 unit comes pre-installed with a Vent Installation Detector (“VID”) to assist the installer in properly installing the Intake Air/Exhaust Vent Pipe (“Vent Pipe”) into the Intake Air/Exhaust vent collar.

How It Works

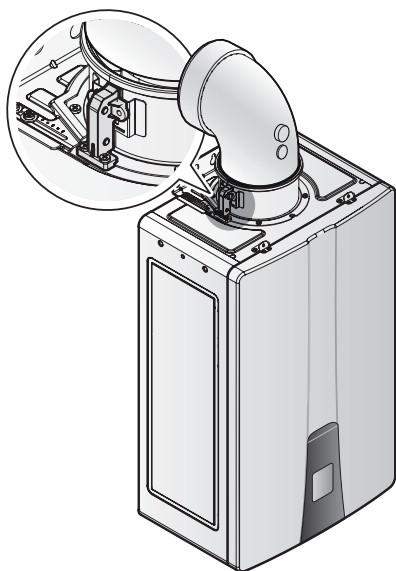

As shown, the VID is a device connected to the vent collar which is intended to detect whether the Vent Pipe has been inserted to a sufficient depth into the collar during its initial installation.

During installation, the VID detects whether the vent pipe is fully inserted (at least 1.3 inches or 34 mm) into the collar. If a correctly sized vent pipe (5.0 inch diameter) is fully inserted into the collar, it will press against a switch to activate the VID. If the vent pipe is not fully inserted into the collar, the unit will display an error message and will not operate. Make sure the vent pipe is correctly sized and has been inserted properly if Error 762 appears.

Purpose

The VID's purpose is to guide the installer to fully insert the vent pipe to a depth of at least 1.3 inches or 34 mm, into the collar. If the vent pipe is not properly inserted and installed, it could separate from the collar resulting in flue gas spillage and carbon monoxide emissions which will result in severe personal injury or death.

! WARNING

Periodically inspect all vent pipe connections.

The Vent Installation Detector (VID) will NOT detect the separation of connected vent pipe if the joints become detached or are leaking flue gas that may contain carbon monoxide.

The VID is not intended and should not be relied upon to detect all instances of vent pipe movement or separation from the collar.

Various factors, including but not limited to sensor failure, switch sticking and corrosion, may cause the VID to not properly function if the vent pipe separates from the collar.

Limitations

The VID is not an alarm, safety switch or a substitute for a carbon monoxide detector. The VID may not cause the unit to stop operating if the vent pipe is partially or completely dislodged. Other factors can impact the performance of the VID causing it to be unable to function as intended. Such factors include, but are not limited to, deformity of the vent pipe, not using a correctly sized vent pipe, misalignment of the vent pipe into the collar, vertical movement of the vent pipe caused by improper installation, and other misuse or non-conformance with installation instructions.

! WARNING

Carbon Monoxide Hazard

To prevent serious injury or death:

- ALWAYS insert vent pipe 1.3 in (34 mm) into the water heater exhaust collar.
- If the vent pipe is not fully inserted, the vent installation detector switch may not detect its presence and the water heater may not operate.

⚠ WARNING

- ALWAYS only use the correctly sized vent pipe materials or an error code E762 can appear on the front panel if the vent pipe is not properly installed.
- The factors that can effect the performance of the VID include, but are not limited to, deformity of the vent pipe, not using a correctly sized vent pipe, misalignment of the vent pipe into the collar, vertical movement of the vent pipe caused by improper installation, and other misuse or non-conformance with installation instructions.
- Periodically inspect all vent pipe connections. The VID is not intended and should not be relied upon to detect all instances of vent pipe movement or separation from the collar.

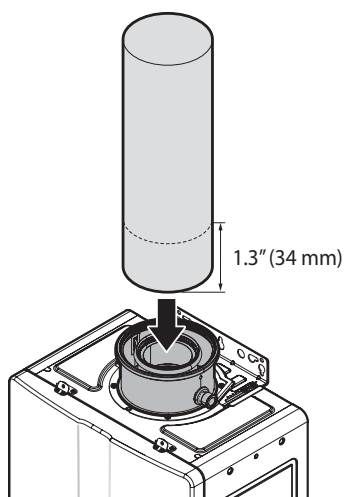

⚠ WARNING

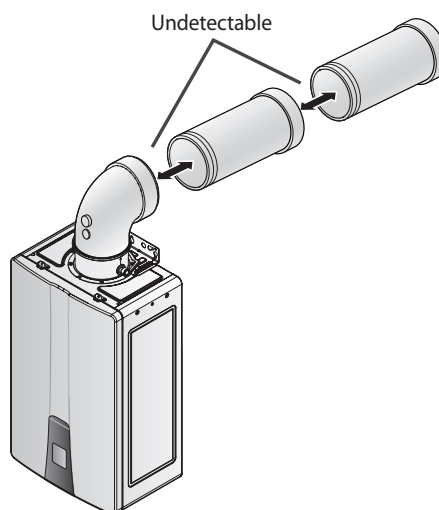
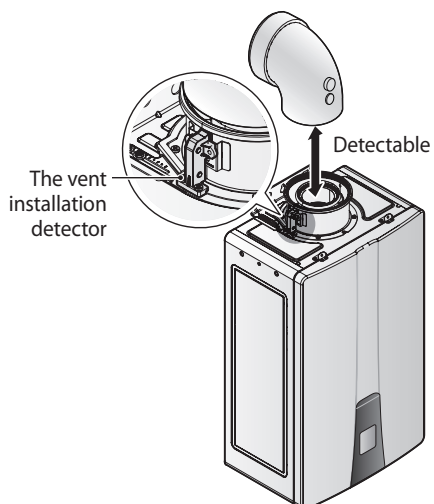

3.5.2 Maintaining Clearances

Terminal Clearances

Maintain the following venting clearances, as required by **ANSI Z21.10.3 and the National Fuel Gas Code, ANSI Z223.1/NFPA 54**:

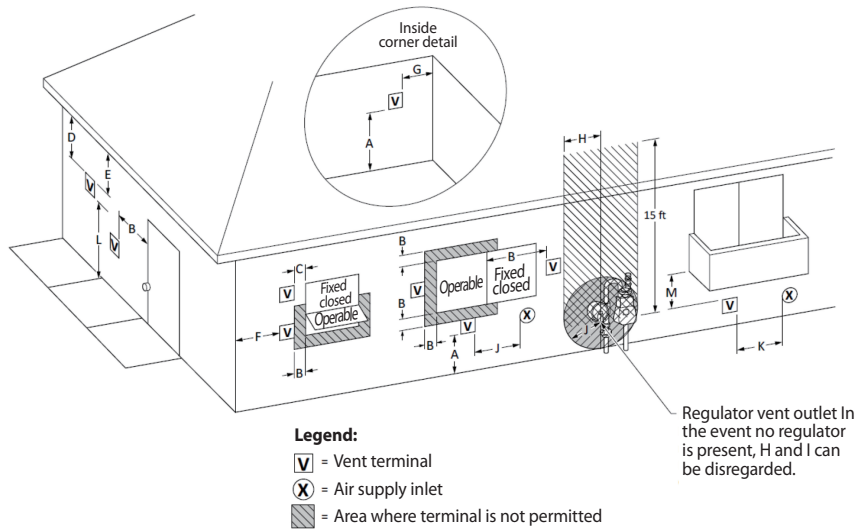

For Interior Models (Direct Vent)

Ref	Description	US Direct Vent Installations ¹
A	Clearance above grade, veranda, porch, deck, or balcony	12 in (30 cm)
B	Clearance to window or door that may be opened	12 in (30 cm)
C	Clearance to permanently closed window	0 in (0 cm) ³
D	Vertical clearance to ventilated soffit located above the terminal within a horizontal distance of 2 ft (61 cm) from the center line of the terminal	Equal or greater than soffit depth ^{2,3}
E	Clearance to unventilated soffit	Equal or greater than soffit depth ^{2,3}
F	Clearance to outside corner	2 ft (61 cm)*
G	Clearance to inside corner	12 in (30 cm)*
H	Clearance to each side of center line extended above meter/regulator assembly	3 ft (91 cm) within a height of 15 ft (4.6 m)*
I	Clearance to service regulator vent outlet	3 ft (91 cm)*
J	Clearance to nonmechanical air supply inlet to building or the combustion air inlet to any other appliance	12 in (30 cm)
K	Clearance to a mechanical air supply inlet	3 ft (91 cm) above if within 10 ft (3 m) horizontally
L	Clearance above paved sidewalk or paved driveway located on public property	7 ft (2.13 m) [†]
M	Clearance under veranda, porch deck, or balcony	12 in (30 cm) - open on 3 sides*

* Suggested clearances by the manufacturer. If the clearances required by local codes are different from those from the table above, the greater clearance should apply. Direct exhaust vapors and condensate away from building materials to avoid degradation.

The minimum distance from adjacent public walkways, adjacent buildings, openable windows, and building openings shall not be less than those values specified in the National Fuel Gas Code, ANSI Z223.1/NFPA 54.

1 In accordance with the current ANSI Z223.1/NFPA 54 National Fuel Gas Code

2 Soffit with 12" depth requires a minimum of 12" vertical clearance from the termination (36" soffit requires a minimum of 36" vertical clearance)

3 In the areas where corrosion and discoloration of building materials can occur, a minimum clearance of 12" shall apply.

† A vent shall not terminate directly above a sidewalk or paved driveway that is located between two single family dwellings and serves both dwellings.

‡ Permitted only if veranda, porch, deck, or balcony is fully open on a minimum of two sides beneath the floor.

Note

If locally adopted installation codes specify clearances different than those illustrated, then the most stringent clearance shall prevail.

For Exterior Models (Non-Direct Vent)

Ref	Description	US Non-Direct Vent Installations ¹
A	Clearance above grade, veranda, porch, deck, or balcony	12 in (30 cm)
B	Clearance to window or door that may be opened	48 in (120 cm) below or to side of opening; 12 in (30 cm) above opening
C	Clearance to permanently closed window	0 in (0 cm) ³
D	Vertical clearance to ventilated soffit located above the terminal within a horizontal distance of 2 feet (61 cm) from the center line of the terminal	Equal or greater than soffit depth ^{2,3}
E	Clearance to unventilated soffit	Equal or greater than soffit depth ^{2,3}
F	Clearance to outside corner	2 ft (61 cm)*
G	Clearance to inside corner	12 in (30 cm)*
H	Clearance to each side of center line extended above meter/regulator assembly	3 ft (91 cm) within a height of 15 ft (4.6 m)*
I	Clearance to service regulator vent outlet	3 ft (91 cm)*
J	Clearance to non-mechanical air supply inlet to building or the combustion air inlet to any other appliance	48 in (120 cm) below or to side of opening; 12 in (30 cm) above opening
K	Clearance to a mechanical air supply inlet	36 in (91 cm) above if within 10 ft (3 m) horizontally
L	Clearance above paved sidewalk or paved driveway located on public property	7 ft (2.13 m) [†]
M	Clearance under veranda, porch deck, or balcony	12 in (30 cm) - open on 3 sides*

* Suggested clearances by the manufacturer. If the clearances required by local codes are different from those from the table above, the greater clearance should apply. Direct exhaust vapors and condensate away from building materials to avoid degradation.

The minimum distance from adjacent public walkways, adjacent buildings, openable windows, and building openings shall not be less than those values specified in the National Fuel Gas Code, ANSI Z223.1/NFPA 54.

1 In accordance with the current ANSI Z223.1/NFPA 54 National Fuel Gas Code

2 Soffit with 12" depth requires a minimum of 12" vertical clearance from the termination (36" soffit requires a minimum of 36" vertical clearance)

3 In the areas where corrosion and discoloration of building materials can occur, a minimum clearance of 12" shall apply.

† A vent shall not terminate directly above a sidewalk or paved driveway that is located between two single family dwellings and serves both dwellings.

‡ Permitted only if veranda, porch, deck, or balcony is fully open on a minimum of two sides beneath the floor.

Note

If locally adopted installation codes specify clearances different than those illustrated, then the most stringent clearance shall prevail.

Clearances for Sidewall Terminations

Multiple-unit, concentric wall terminals: Space each concentric wall terminal at least 12 in (30 cm) apart, regardless of the orientation. A concentric wall terminal must also be at least 12 in (30 cm) away from the inside corner of a wall. If the adjacent wall is less than 12 in (30 cm) in length, the minimum required distance away from the inside corner will be equal to the length of the adjacent wall.

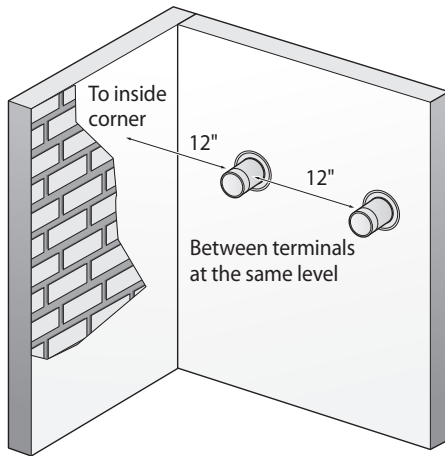

[NHW700-SU/AI Models]

Clearances for Rooftop Terminations

The minimum spacing required between multiple concentric terminals on different levels of a rooftop is 60 in (150 cm).

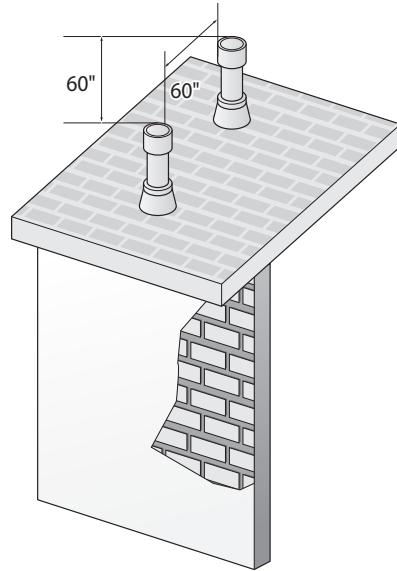

[NHW700-SU/AI Models]

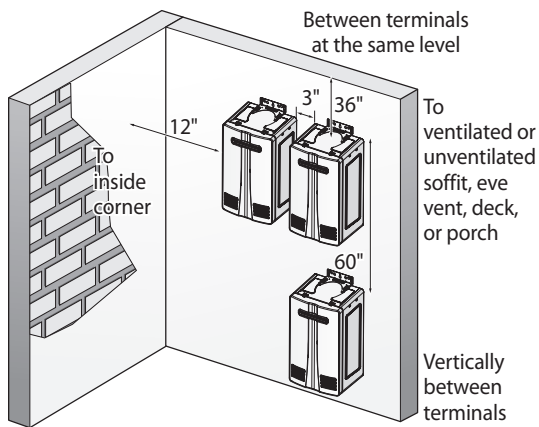

[NHW700-SE/AE Models]



3.5.3 Measuring Vent Length (Universal/Interior Models Only)

Refer to the table to find the maximum vent length based on the number of elbows. (Two 45 degree elbows count as one 90 degree elbow.)







Vent Type	Diameter	Number of 90° Elbows	Maximum Vent Length
Concentric	3 in. / 5 in. (80 mm / 125 mm)	0	20 ft (6 m)
		1	15 ft (4.5 m)
		2	10 ft (3.0 m)
		3	5 ft (1.5 m)





Note

- The Maximum Vertical and Horizontal (Total) Vent Length does not include any elbows.
- Each 90° elbow is equivalent to 5 feet of vent length.
- Two 45° elbows are equivalent to one 90° elbow.
- The value in the table include the terminating vent length.

NaviVent Vent Components	Equivalent Length
	3 ft (91 cm)
	5 ft (1.5 m)
	5 ft (1.5 m)

NaviVent Vent Components

Concentric Sidewall Termination Kit		Vent Pipe Extension		Concentric Elbow	
					
11-1/2" (292mm) Length Navien Part #GXXX001891 UPC #884954220925	21" (533mm) Length Navien Part #GXXX001892 UPC #884954220932	10" (254mm) Length Navien Part #GXXX001896 UPC #884954220970	39" (990mm) Length Navien Part #GXXX001897 UPC #884954220987	45° Elbow Navien Part #GXXX001894 UPC #884954220956	90° Elbow Navien Part #GXXX001895 UPC #884954220963
*Includes: One Sidewall Termination, One 90° Elbow, Two Wall Plates					

Replacement Gasket		Concentric Roof Termination		
				
Blue Silicone Navien Part #GXXX001898 UPC #884954220994	Black EPDM Navien Part #GXXX001899 UPC #884954221007	18" Length Navien Part #GXXX001893 UPC #884954220949	Ø5" Flat Roof Flashing Navien Part #GXXX001900 UPC #884954221014	Ø5" Adjustable Roof Flashing Navien Part #GXXX001901 UPC #884954221021

Metal Wall Strap	Condensate Trap
	
6 Straps per Box Navien Part #GXXX001902 UPC #884954221038	Navien Part #GXXX001952 UPC #884954228150

Metal-Fab, Inc. – Alternate Certified Vent Components (Certified to UL1738)

Note

Refer to the contact information of the manufacturer if necessary:

- Manufacturer: Metal-Fab
- Tel: 800-835-2830
- E-mail: info@mtfab.com
- Website: www.metal-fabinc.com

Item	Description
3CGV36	36" Vent Pipe
3CGV24	24" Vent Pipe
3CGV12	12" Vent Pipe
3CGV6	6" Vent Pipe
3CGVAL	Telescopic Vent 21" to 35"
3CGVAL20	Telescopic Vent 13" to 20"
3CGV45L	45 degree Elbow
3CGV90L	90 degree Elbow
3CGVRVT or 3CGRVT	Vertical Roof Termination
3CGVSC	Storm Collar
3CGVF-12, 3CGVF, 3CGVFT	Roof Flashing
3CGVPS	Support Plate
3CGVTR	Trim Ring
3CGVWH1, 3CGVWS1	Metal Wall Strap
3CGVWPK, 3CGVWPKS	Wall Thimble
3CGVRHT or 3CGRHT	Horizontal Termination
3CGVPHK3	Low Profile Horizontal Vent Termination Kit for up to 6" wall
3CGVPHK4	Low Profile Horizontal Vent Termination Kit for up to 8" wall
3CGVRLSHK or 3CGRLSHK	Standard Horizontal Vent Termination Kit
3CGVRLSV or 3CGRLSV	Appliance Adapter (Required to connect unit to Metal Fab venting)
3CGVDS	Vertical Drain Section
3CGDS	Horizontal Drain Section
3CGVDMA	Male to Male Adapter
3CGVDFA	Female to Female Adapter

3.5.4 Terminating the Vent

Before installing the water heater, determine what type of vent termination is appropriate for the installation location and situation. Examples in this section describe typical venting configurations, but they do not include all possible options.

The following installation guidelines can be used. Refer to the vent manufacturer's instructions for detailed installation procedures.

Horizontal Termination

Regions with cold climates will produce more condensate in the vent system. The condensate collector should be used in cold climates. If more than one elbow is used in the vertical section, the condensate collector must be used. The condensate collector must also be used in horizontal terminations if a vertical rise in the vent system exceeds 5 ft. Slope the vent $\frac{1}{4}$ " per foot downward towards the termination or upward if using a condensate collector as illustrated below.

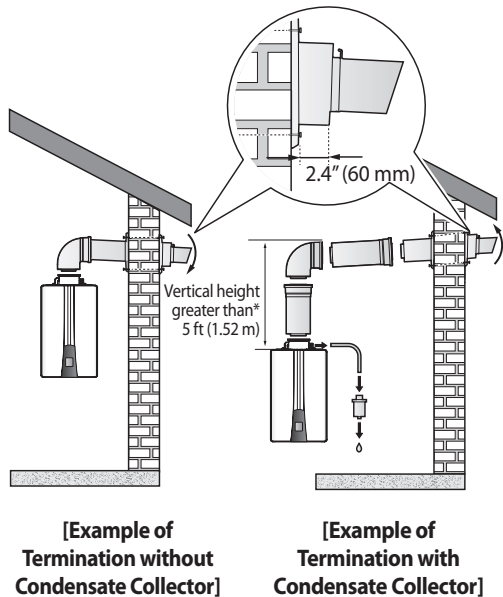

Note

Secure the wall thimble plate to the vent pipe and the wall by tightening the provided screws in the left and right screw holes.

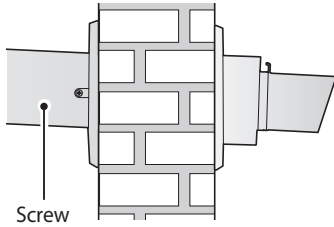

Vertical Termination

Use a condensate collector in all installations.

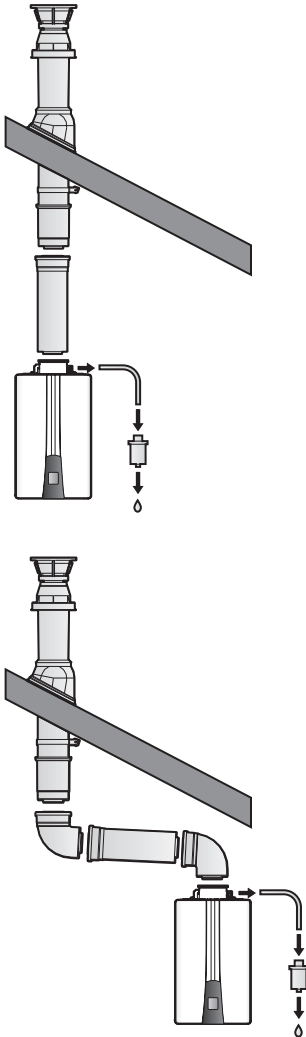

3.5.5 Draining Condensate (Indoor Installation Only)

⚠ WARNING

If a condensate trap hose is installed, the water inside the hose should be higher than 5.1 in (130 mm), and water should be inside the hose before operating the water heater. Do not remove the condensate collector cap unless a condensate trap is attached. If a condensate trap is not installed properly as explained above, it could result in injury or death.

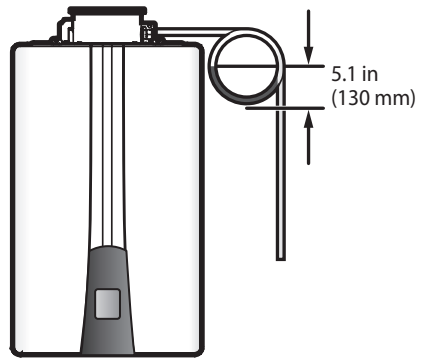

NOTICE

The water heater will create condensation when it operates. Condensate will eventually damage the heat exchanger if it is not drained properly. Follow all local codes and regulations when disposing the condensate from the water heater.

Installation

- For vertical terminations, install a condensate drain and trap as close to the appliance as possible.
- Slope the vent in accordance with the vent manufacturer's installation instructions.
- Use only corrosion resistant materials for the condensate drain lines, such as PVC pipe or plastic hose.
- The condensate drain pipe (along its entire length) must be at least the same diameter as the drain line (5/8 inch).
- The end of the condensate drain pipe should be open. The end should not be under water or any other substances.
- To help prevent the condensate from freezing, run the condensate drain line through an interior wall or between insulation and an interior wall.
- The condensate collector should be used for all combination domestic/hydronic heating applications.

Guidelines

- Do not allow condensate to enter the water heater.
- Do not connect the condensate drain pipe directly to the storm sewer.
- Do not connect the condensate drain line with the evaporator coil drain of an air conditioner.
- Do not connect the condensate drain line to the pressure relief valve or the line of the appliance.
- Use only venting that is approved and identified as acceptable for your particular model.

3.6 Connecting the Power Supply

WARNING

Electric Shock Hazard

To prevent serious injury or death:

- ALWAYS follow all applicable electrical codes of the local authority having jurisdiction.
- In the absence of such requirements, follow the latest edition of the National Electrical Code (NFPA 70) in the USA or the latest edition of CSA C22.1 Canadian Electrical Code Part 1 in Canada.
- ONLY licensed professionals should connect the power supply.

When connecting the power supply, follow these guidelines:

- Do not connect the electric supply until all plumbing and gas piping is complete and the water heater has been filled with water.
- Do not connect the water heater to a 220-240 V AC power supply. Doing so will damage the water heater and void the warranty.
- Universal/Interior models come with a factory-installed, 3-pronged (grounded) plug. Exterior models come with 3 exposed power wires (line/neutral/ground) for direct connection to outdoor-rated wiring. The water heater can be plugged into any grounded electrical outlet nearby, as it requires only 2-4 Amps.
- Keep power cord free of dust.
- Do not use a broken or modified power cord.
- Do not bind, bend or stretch power cords.
- If local codes require the water heater to be wired directly, remove and discard the factory-installed plug. Install a power switch between the breaker and the water heater to facilitate end-user maintenance and servicing. Connect the water heater to a 110-120V AC at 60 Hz with a maximum of 2 A (4 A if an external pump connected) for non-pump model, 4 A for A model rating electrical supply.
- A junction box is provided underneath the water heater if a direct electrical connection is required.

- The water heater must be electrically grounded. If using the power plug, ensure that the electrical outlet you connect the water heater to is properly grounded. If wiring the water heater directly to a power supply, do not attach the ground wire to either the gas or the water piping as plastic pipe or dielectric unions may prevent proper grounding.
- We recommend using a surge protector to protect the water heater from power surges.
- If there is a power failure in cold weather areas, the freeze prevention system in the water heater will not operate and may result in freezing of the heat exchanger. In cold weather areas where power failures are common, you must completely drain the water heater to prevent damage if the power will be off for any extended period of time. A battery back-up (available at most computer retailers) may be used to supply hot water during periods of power outages. **Damage caused by freezing temperatures due to power loss is not covered under warranty.**

If you are not using your water heater for an extended period:

1. Completely drain the water out of the water heater.
2. Disconnect the power supply to the water heater. This prevents your water heater from freezing and being damaged.

⚠ WARNING

Electric Shock Hazard

To prevent serious injury or death:

- ALWAYS label all wires before disconnecting them when you work on the controls.
- Wiring errors can cause improper and dangerous operation.
- ALWAYS verify proper operation after servicing.

Disconnect Switch (Exterior Models Only)

On exterior models, there must be a disconnect switch installed for the incoming 120 V AC power. It should be designed to be suitable for outdoor use. Make sure that you are in compliance with the National Electrical Code, ANSI/NFPA 70, and your local codes to ensure that you are using a proper switch type for your area.

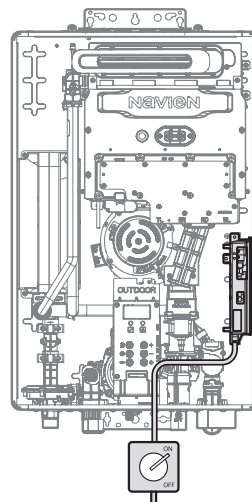

3.7 Setting the DIP Switches

The water heater has two DIP switch locations: on the main circuit board (PCB) and on the front panel. Each location has two sets of DIP switches that control the functionality of the water heater. Set the DIP switches appropriately, based on the installation environment.

3.7.1 Circuit Board DIP Switches

The two sets of DIP switches on the circuit board configure the water heater's model settings. These configurations are set at the factory and should not be changed.

3.7.2 Setting the Front Panel DIP Switches

The two sets of DIP switches on the front panel configure the water heater's pump & recirculation, display, well pump, storage tank & solar system, lime alarm, high altitude, cascade venting and gas type settings. Some of these configurations are set at the factory and should not be changed. The following tables describe the functions of the DIP switches and their settings:

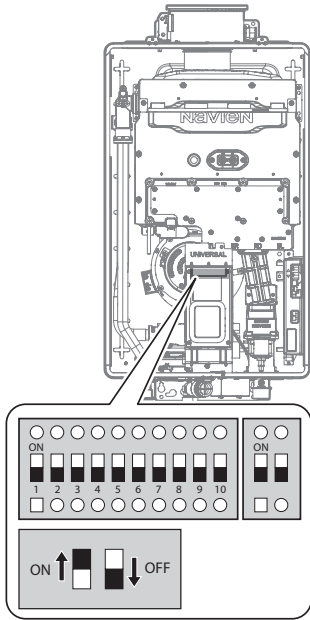

[NHW700-SU Models]

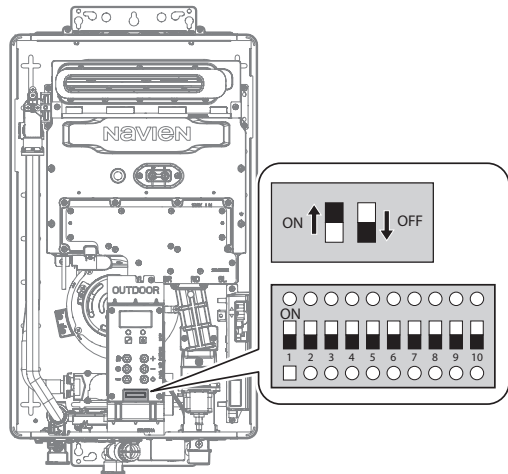

[NHW700-SE Models]

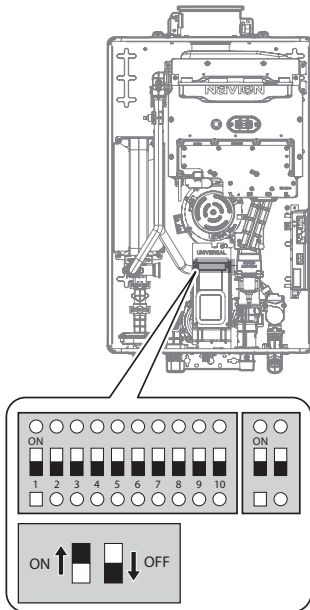

[NHW700-AI Models]

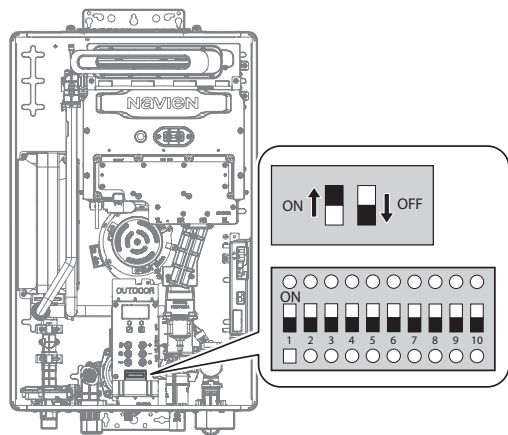

[NHW700-AE Models]

- 10-switch Panel:

Switch	Function		Setting	Remark	
1	Gas Type	Off	Natural Gas	<p>*Preheating:</p> <ul style="list-style-type: none"> • Preheating starts when remote controller is not connected. • When remote controller is connected, preheating starts and operates based on the timer. • Set the timer on the remote controller to use hot water at the time of your choice. • Preheating does not function in Cascade Mode (Preheating OFF). • Freeze protection is still available with preheating OFF. <p>**External Pump:</p> <p>These settings are to be used when an external pump is wired to the water heater.</p> <p>***High Altitude</p> <p>Above 2,000 ft (610 m), the water heater will de-rate by 3% with Natural Gas and by 4% with Propane for each 1,000 ft (305 m) of altitude gain.</p>	
		On	Propane Gas		This can only be selected when the power is on or when the DIP switch error has been solved.
2	Recirculation Mode		Preheat* Not Used		2: OFF, 3: OFF
			Internal Circulation Preheating (AI/AE ONLY)		2: ON, 3: OFF
3			External Circulation Preheating		2: OFF, 3: ON 2: ON, 3: ON
4	Display Temperature Unit		Celsius		4: ON
			Fahrenheit		4: OFF
5	Well Pump		Well Pump Operation		5: ON
			Do Not Use Well Pump		5: OFF
6	DHW Storage Tank		Storage Tank Operation		6: ON
			Do Not Use Storage Tank	6: OFF	
7	Commercial Lock		Temperature can be set.	7: OFF	
			Temperature cannot be set.	7: ON	
8	Limescale Detection Alarm		Disable the limescale detection alarm.	8: OFF	
			Use limescale detection alarm. (12 month interval)	8: ON	
9 & 10	High Altitude *** (Universal/Interior Models Only)		0–1,999 ft (0–609 m)	9: OFF, 10: OFF	
			2,000–5,399 ft (610–1,645 m)	9: ON, 10: OFF	
			5,400–7,699 ft (1,646–2,346 m)	9: OFF, 10: ON	
			7,700–10,100 ft (2,347–3,078 m)	9: ON, 10: ON	

Note

- This water heater may be installed at elevations up to 10,100 ft (3,078 m) for use with Natural Gas and Propane. To use the water heater at a specific altitude, the DIP switches should be set as described above.
- Please confirm the installation elevation by using the provided QR code to access the following website (<https://www.navienc.com/elevation>) and entering the proper zip/postal code.



- Exterior models can only be installed under 4,500 ft (1,370m), and the High Altitude setting cannot be applied.



NOTICE

Do not configure the system for DHW recirculation when it is configured to run an air handler using the H2Air controller. DHW recirculation and Navien H2Air configurations cannot be used at the same time.

4. Configuring the Remote Controller System

4.1 Included Items

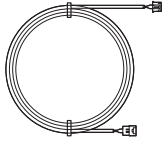
When you open the box, you will find the following items with the remote controller. Check the box for each of the following items before installing the remote controller.

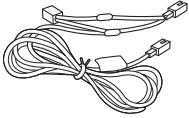
	
Remote Controller	Extension Cable
	
2 Tapping Screws	Wall Mounting Bracket
	
Multi Remote Controller Cable (optional)	

4.2 Connecting the Extension Cable

1. Connect one end of the extension cable to the port on the front panel of the water heater.
2. Pass the other end of the extension cable through the hole in the bracket.

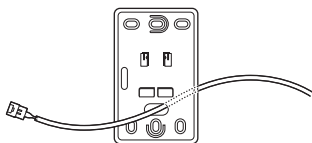

3. Connect the end of the extension cable to the cable connected to the remote controller.

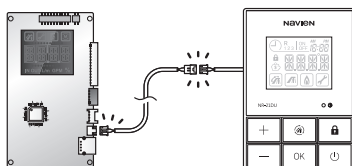

Note

- You can connect up to 2 remote controllers if necessary. (Optional)

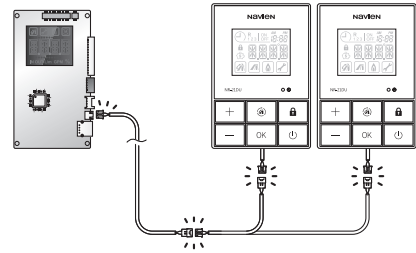

- Connect the wiring from the second remote in parallel with the existing remote controller. One remote must also be designated as the MAIN controller. For more information, refer to “4.5 Multi Remote Controller System” on page 60.
- The length of the extension cable is 7 ft (2 m) and can be extended using 18AWG wire up to 300 ft (91 m).

4.3 Attaching the Wall Mounting Bracket

1. Affix the bracket securely to the wall by fastening 2 screws to the wall or to the 2 holes in the wall receptacle.

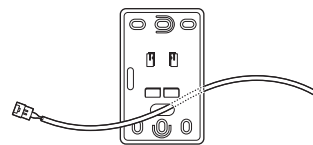

On the wall

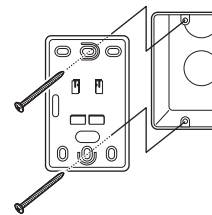

In the wall receptacle

2. Hang the remote controller on the bracket by aligning the hooks.

4.4 Remote Controller

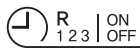
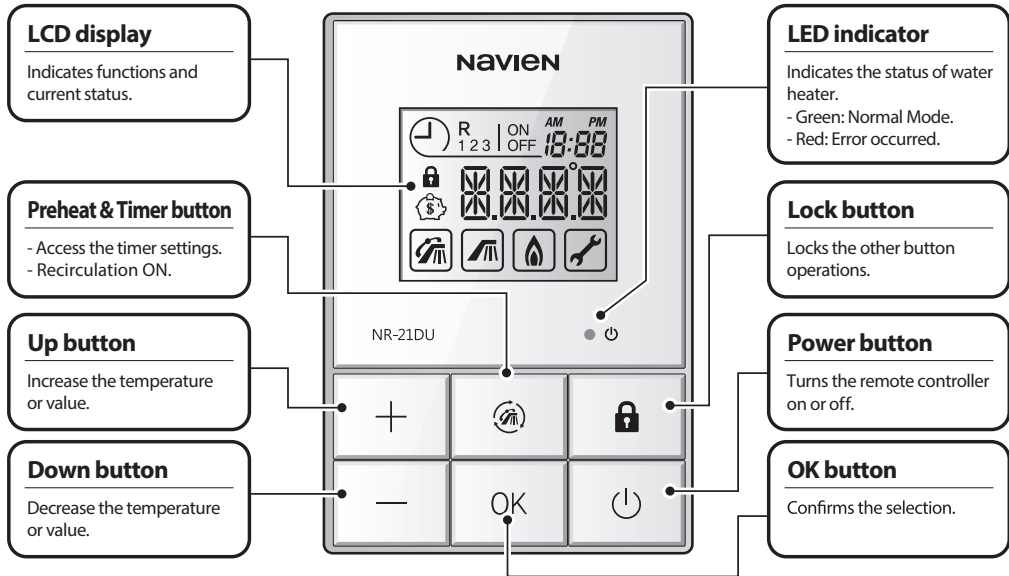

Timer is set.



Recirculation Mode.



Displays the current time.



Hot water is in use.



Displays the current set temperature.



Water heater operation is in progress.



Operations are locked.



An error code will appear on the display.

4.5 Multi Remote Controller System

The multi remote controller system (30022717A) consists of one main remote controller and one sub remote controller. The system must have only one main remote controller.

4.5.1 Initially Setting the Multi Remote Controller System

If you turn on the water heater with the front panel connected to two remote controllers, one of the controllers is set to the main controller randomly. The other controller will display "MAIN" on its LCD display and you have to set its operation mode to Sub.



The remote controller that does not display "MAIN" is already operating as the main controller, you don't have to set its operation mode.

You can set the operation mode of the remote controller that displays "MAIN." When you set the controller as a sub, the multi remote controller system configuration completes.

Note

If you press the OK button on the controller displaying "MAIN" and set its operation mode to Main while the main controller has already been determined, the other controller will display "MAIN" to indicate that you must set the main and sub operation modes properly.

1. Press the Down button on the remote controller displaying "MAIN" to set its operation mode to "SUB."



Then, press the OK button to set the operation mode to Sub.

2. "SL.xx" appears on the display. It represents the standby status to receive the sub remote controller ID from the main remote controller synced to the front panel of the water heater.



3. When the ID is assigned, the ID appears and flashes on the LCD display for 2 seconds.



4. "SYNC" appears on the LCD display for 5-10 seconds until it syncs with the connected panel and the main remote controller after the ID is assigned.



5. When the synchronization completes, identical information will appear on the displays of the main and sub controllers. The two controllers and front panel will be controlled simultaneously by controlling only one controller.

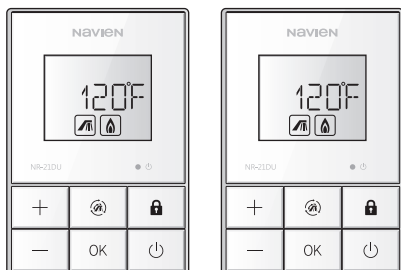

4.5.2 Checking the Multi Remote Controller System Setting

After completing the multi remote controller setting, you can check the setting by pressing the OK button and Lock button simultaneously for 2 seconds.

Verify that the setting is successful by confirming that one controller displays "MAIN" and the other one displays "SUB."

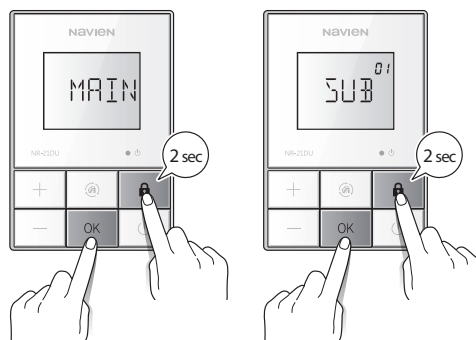

4.5.3 Initializing the Multi Remote Controller System Setting

You can initialize the multi remote controller system when you have to reset or replace the multi remote controllers. Press the Preheat & Timer button and Lock button simultaneously for 2 seconds on any of the controllers.

After initializing the setting, repeat the instructions from the "4.5.1 Initially Setting the Multi Remote Controller System" on page 60.

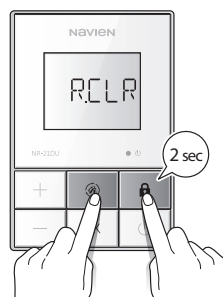

Note

If you initialize only one of the controllers, the other one is initialized automatically.

4.6 Entering Lock Mode

To prevent accidental pressing of the buttons and to prevent children from adjusting the controller, you can activate the Temperature Lock Mode.

To activate or deactivate Lock Mode, press the Lock button for 2 seconds.

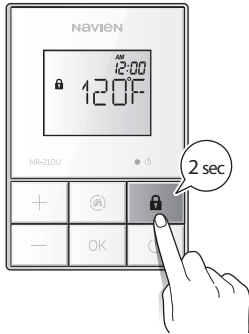

When Lock Mode is activated,

- The Lock icon appears on the display.
- All buttons except for Lock button are locked.

Note

- Resetting errors or alarms is still available with Lock Mode activated.
- You can change the settings from the front panel with Lock Mode activated.

4.7 Setting the Clock

1. Press the Preheat & Timer button for 2 seconds.

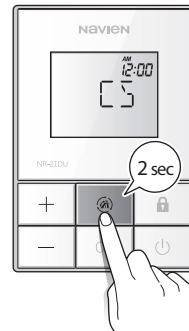

2. Adjust the minutes by pressing the Up or Down Button.

Press the OK button to set the minutes.

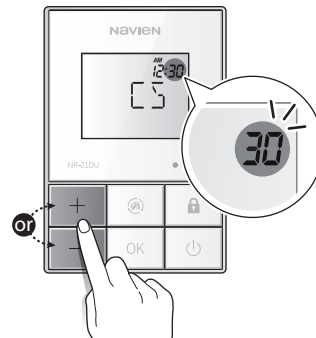

3. Once the minutes are set, adjust the hour by pressing the Up or Down button.

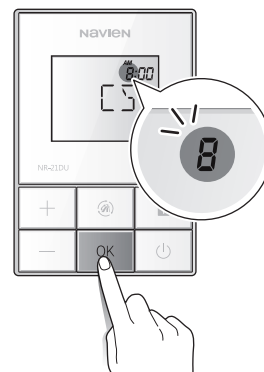

4. Press the OK button to finish and save the updated time.



2. Set the recirculation activation time by pressing the Up or Down button.

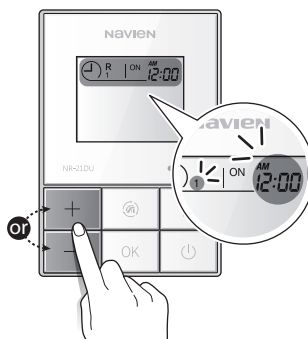

Then, press the OK button to set the deactivation time.

4.8 Setting the Recirculation Timer

1. Press the Preheat & Timer button to set the Recirculation timer while setting the clock. Reservation Schedule #1 is ready to be set.

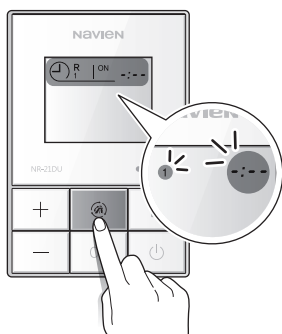

Note

This feature is available only when external circulating pumps are connected and ON.

Note The recirculation timer settings are divided in 30 minute increments.

3. Set the deactivation time by pressing the Up or Down button.

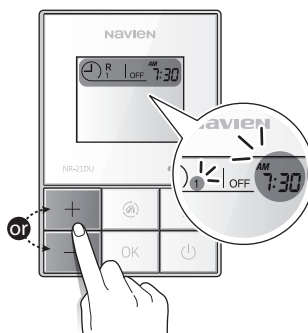

4. Press the OK button to save the timer setting. Repeat these procedures for Reservation Schedule #2 and #3.



- During the reservation schedule, the preheating icon turns on and the Reservation area starts flashing.

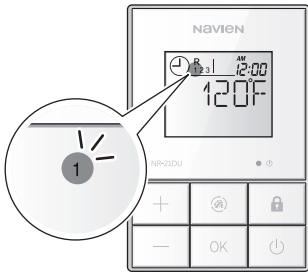

4.9 Starting Recirculation

Press the Preheat & Timer button to start recirculation immediately, regardless of the reservation schedule.

“HEAT” appears for 4 seconds on the display and then recirculation runs once.



During the recirculation, the preheating icon flashes continuously.

Note

- This feature is available only when external circulating pumps are connected and ON.
- This feature runs during the recirculation time set on the front panel which the remote controller is connected to.

4.10 Canceling all Timer Settings

Press and hold the Preheat & Timer and OK button simultaneously for 2 seconds.

“CLR” appears for 3 seconds and all timer settings are canceled.

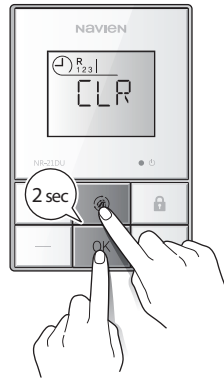

5. Installing a Cascade System

When installing a cascade system, carefully consider the design of the system and the features of the installation location. Follow all local codes and regulations, as well as all guidelines for installing the water heater. The following sections describe additional considerations that are specific to installing cascade systems. Read them carefully before designing or installing the system.

5.1 Connecting Water Supplies

Several options are available for plumbing a cascade system of water heaters. The options shown here are only examples. The setup you choose will vary based on the installation location, local building codes, and other factors. Follow all applicable regulations when installing a cascade system.

You can connect up to two water heaters to meet high-volume hot water demands.

Multiple NHW700-SE/SU Units

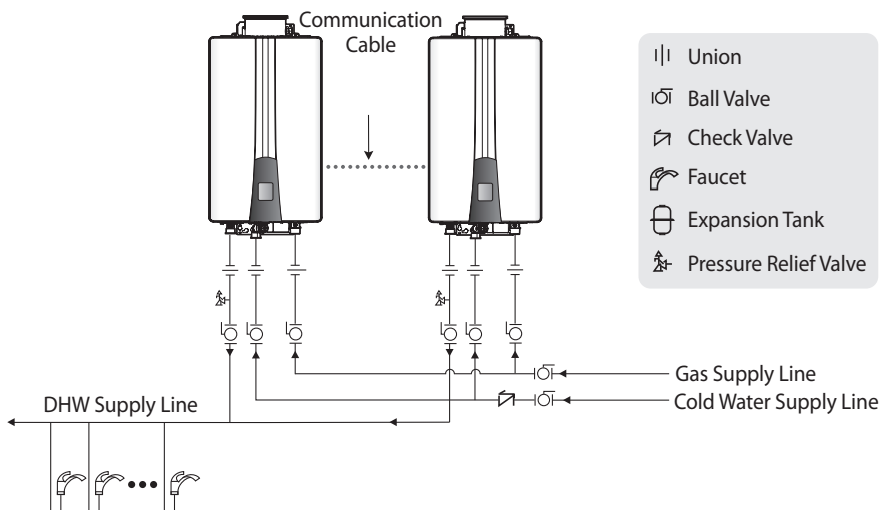

[Example of Water Heater 2-Unit Cascade System]

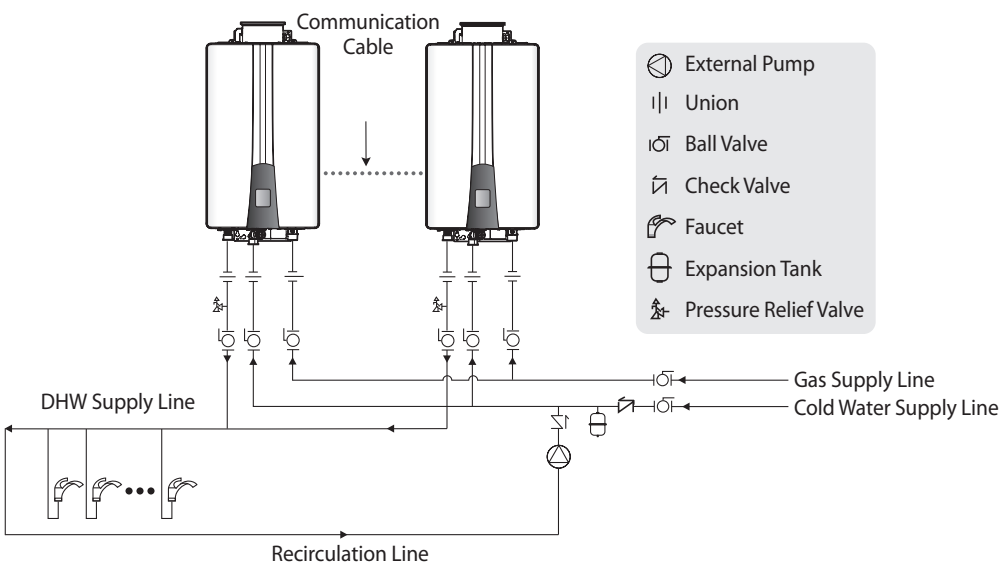

[Example of Water Heater 2-Unit Cascade System with Recirculation]

Recirculation via Internal Pumps (A Model Only)

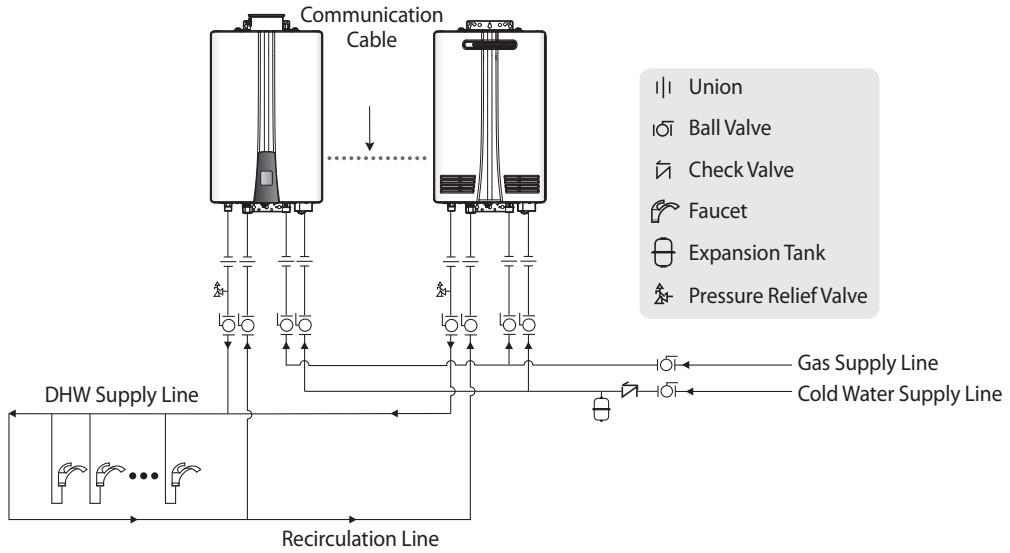

5.1.1 Piping Sizes and Considerations

When plumbing a cascade system, consider the following pipe diameters and flow rates. Note that flow rates above 6.6 ft/s may cause pipe erosion. These specifications may vary depending on installation conditions.

Qty	$\Delta T=54^{\circ}\text{F}$ Flow rate (GPM)	Water Velocity (ft/s)	Pipe Diameter (mm/in)	
			mm	in
1	6.02	4.38	20A	$\frac{3}{4}$ in
2	12.04	4.92	25A	1 in

Note The table above is based on model NHW700-199.

5.2 Connecting the Communication Cables

Two water heaters can be connected with Navien Ready-Link communication cables. Select one of the water heaters in the cascade system as the Main water heater, and then connect the other water heater to it as the Sub. Before making any connections, ensure that the power is turned off to all water heaters.

Connect the Ready-Link cables to the J6 ports on the right side of the front panel:

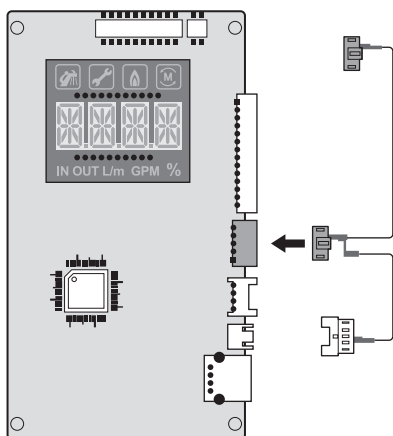

5.2.1 Configuring the Communication Settings

After connecting the Ready-Link communication cables, restore power to the water heater and turn on all water heaters using the Power button.

To configure the communication settings:

1. On the Main water heater, press and hold the **Diagnostic** and **Up (+)** buttons for more than 5 seconds. "MA.00" will appear on the display to confirm that this water heater is set as the Main.

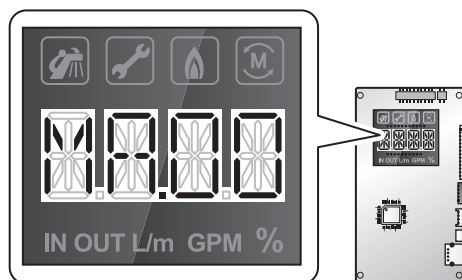

2. On the Sub water heater, press and hold the **Diagnostic** and **Down (-)** buttons for more than 2 seconds. "SL.01" will appear on the display to confirm that this water heater is set as the Sub.

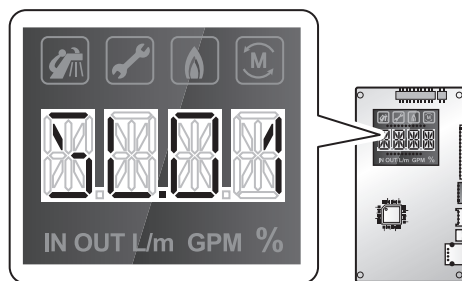

3. On the Main water heater, press and hold the **Diagnostic** and **Up (+)** buttons for more than 5 seconds. The display screen on the configured water heater will return to the temperature display.

Note

To cancel the cascade communication setup, on the Main water heater, press and hold the **Diagnostic** and **Reset** buttons for more than 5 seconds. The water heater will revert to independent operation. Repeat steps 1-3 to reassign the Main water heater.

6. Appendixes

6.1 Covering the Clamps with Front Cover Cap (for NSF 5 Use Only)

After installing the water heater completely, cover the indicated clamps with the front cover caps provided with the product.

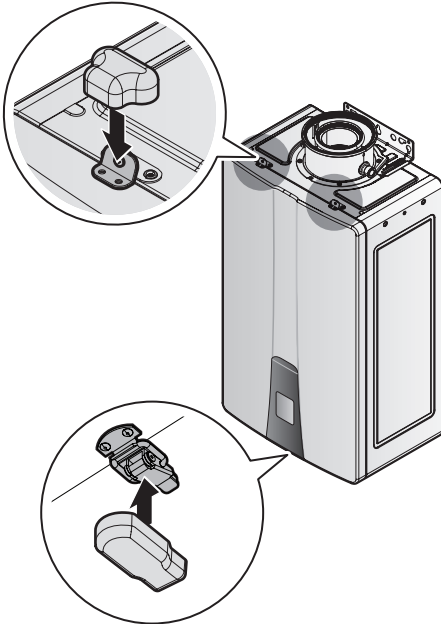

Note

The front cover caps must be used if NSF 5 is required.

6.2 Technical Data

6.2.1 Outlet Flow vs Temperature Rise Curves

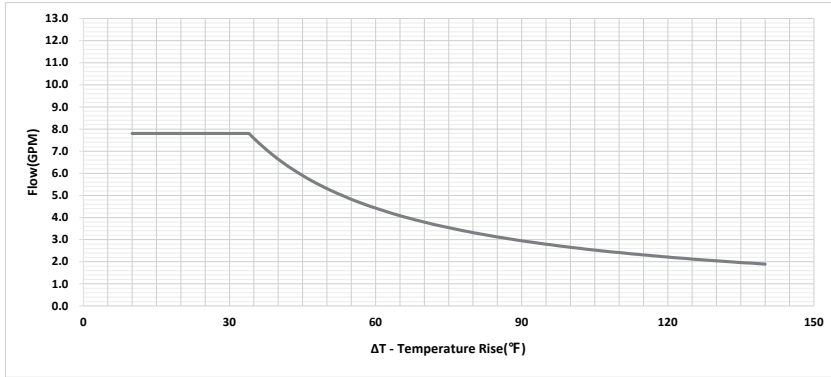

[NHW700-160SE/160SU/160AE/160AI]

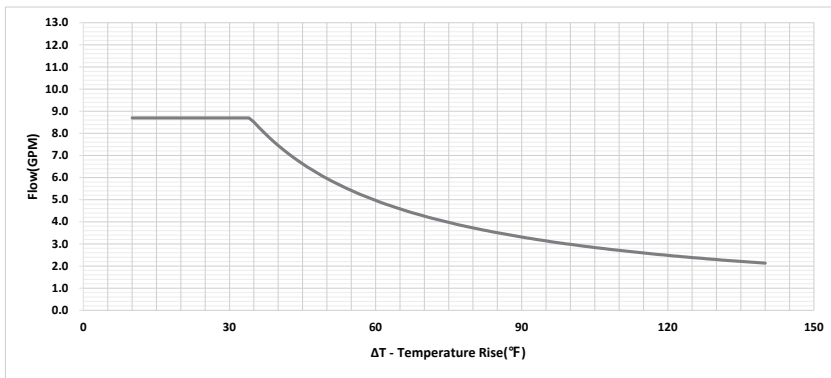

[NHW700-180SE/180SU/180AE/180AI]

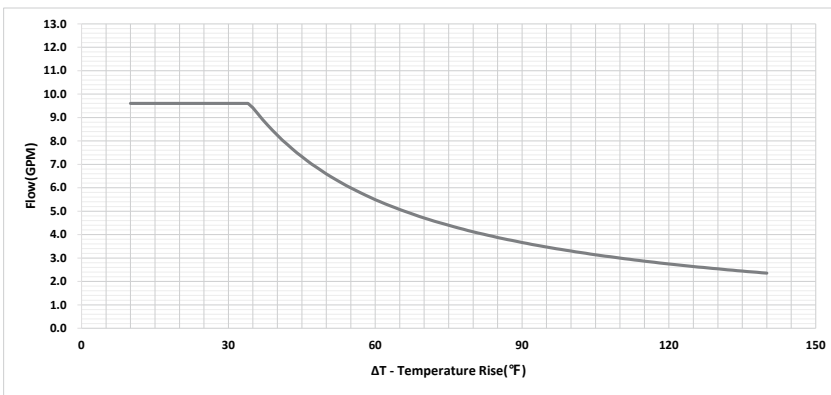

[NHW700-199SE/199SU/199AE/199AI]

Note

At a high Altitude above 2,000 ft (610 m), the water heater will de-rate by 3% with Natural Gas and by 4% with Propane for each 1,000 ft (305 m) of altitude gain.

6.2.2 Pressure Drop Curve

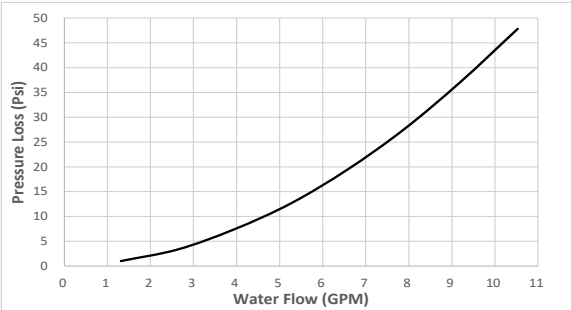

[NHW700-160SE/160SU]

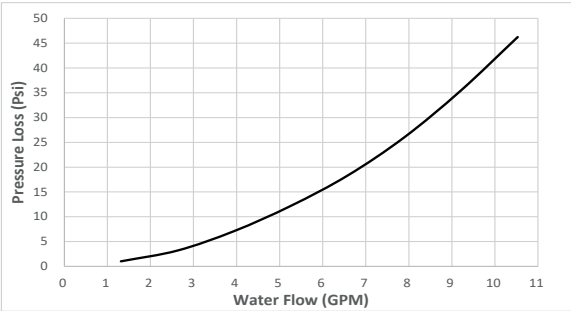

[NHW700-180SE/180SU]

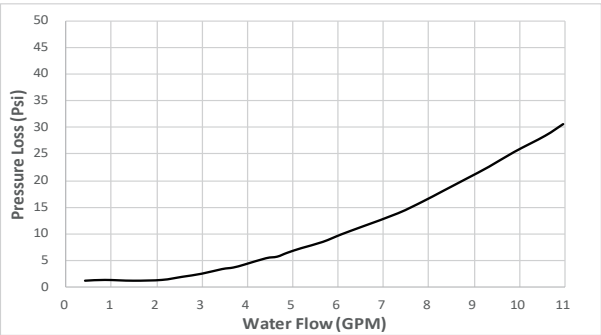

[NHW700-199SE/199SU]

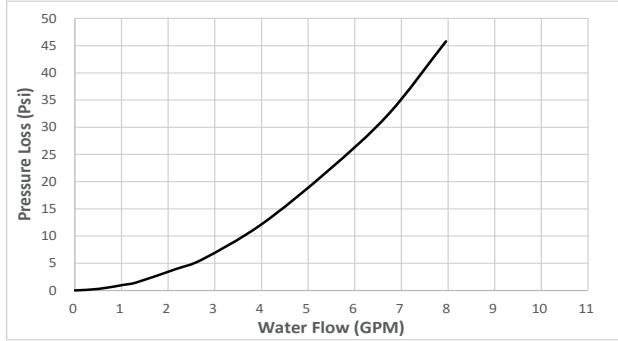

[NHW700-160AE/160AI]

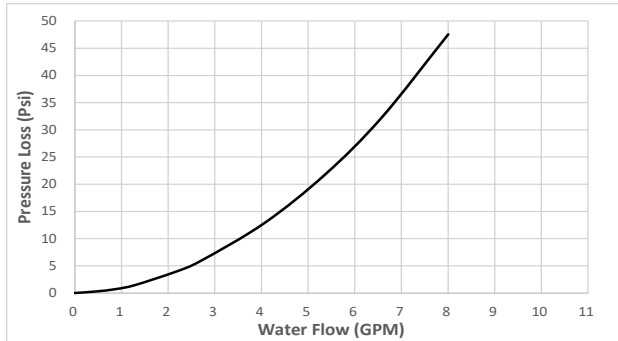

[NHW700-180AE/180AI]

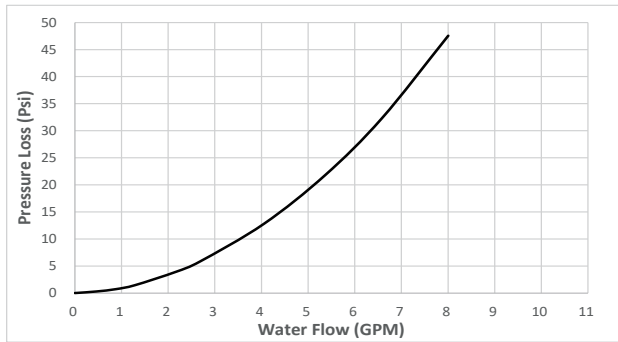

[NHW700-199AE/199AI]

6.2.3 Pump Curve (GPM vs Ft Head)

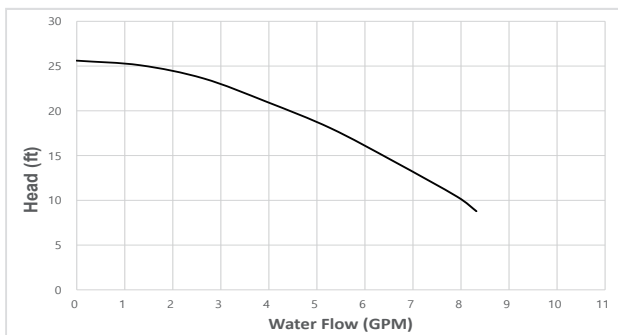

6.3 Wiring Diagram

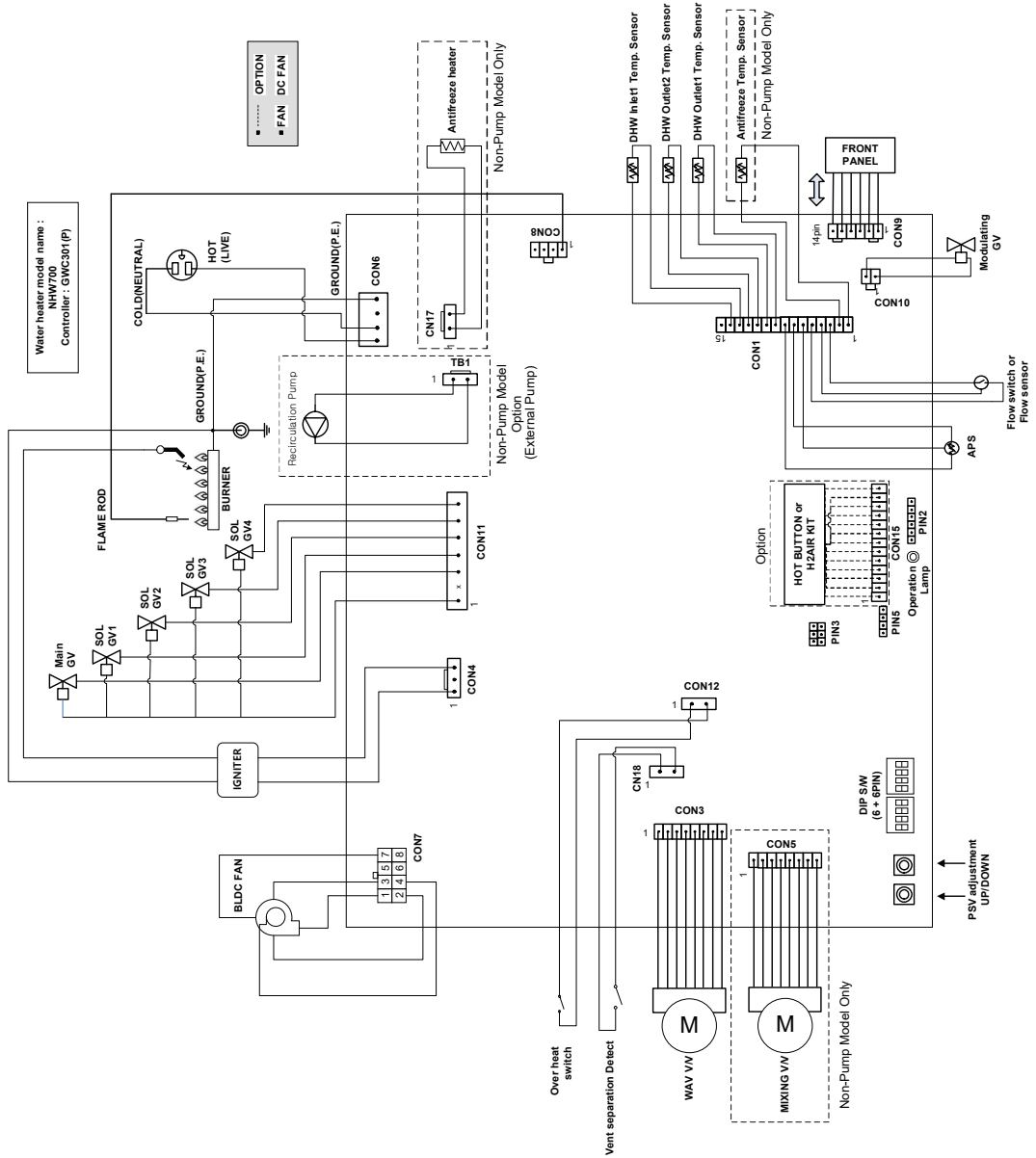

6.4 Ladder Diagram

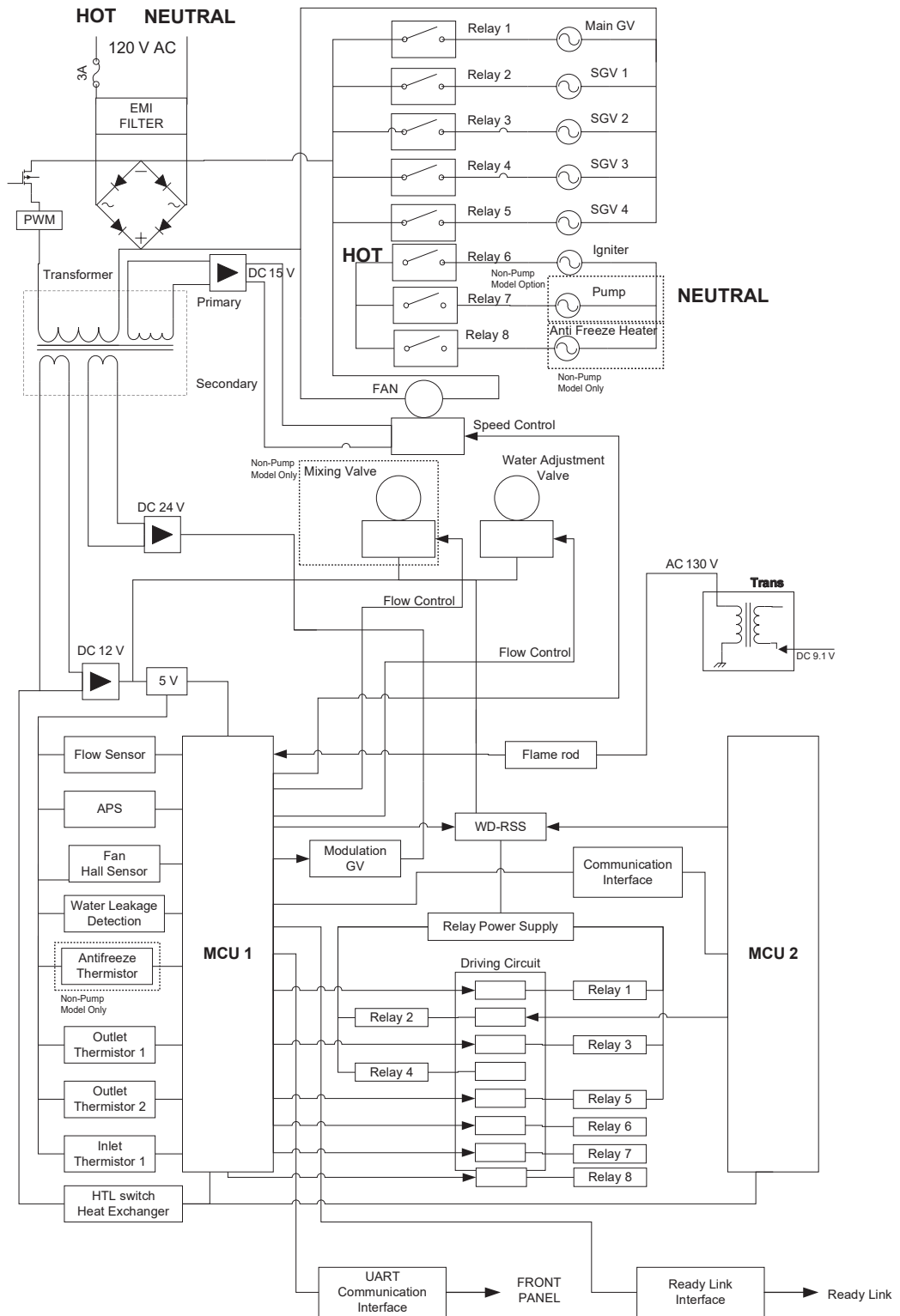

6.5 Component Assembly Diagrams and Parts Lists

6.5.1 Case Assembly (NHW700-160SU/180SU/199SU)

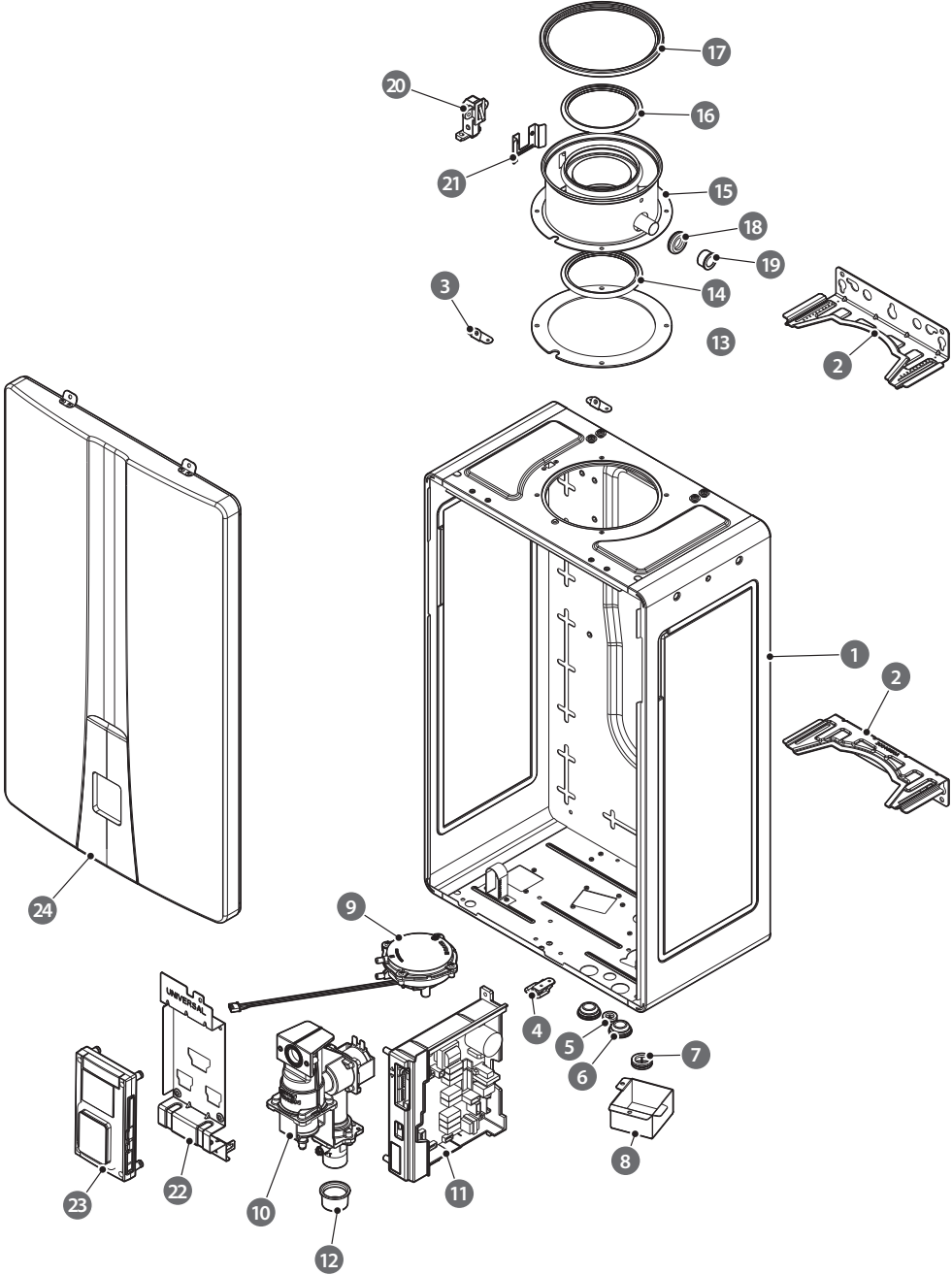

#	Description	Service Part #	Part #	Remark
1	Case	-	20055535A	160SU
		-	20055539A	180SU, 199SU
2	Case Bracket	-	20048190B	
3	Front Cover Bracket	-	20024042A	
4	External Base Toggle Latch	-	20007514B	
5	Rubber Cap	20006973*	20006973B	
6		20025127*	20025127A	
7		20029318*	20029318A	
8	Junction Box	-	20046065B	
9	Air Pressure Sensor	30010238*	30010238B	
10	Gas Control Valve	30022125*	30031342A	
11	PCB	30030638*	30030165A	
12	Pipe Cap	-	20012835A	
13	Exhaust Gasket	30022669*	20047330A	
14	Exhaust Rubber Packing		20046640A	
15	Intake Exhaust Pipe		20052298A	
16	Exhaust Rubber Packing		20046640A	
17	Intake Gasket		20046639A	
18	Condensate Drain Gasket		20046641A	
19	Condensate Drain Cap		20046642A	
20	Exhaust Switch		30024038A	
21	Exhaust Switch Bracket		20048967A	
22	Front Panel Bracket		-	20045993A
23	Front Panel	30030639*	30022766B	
24	External Cover	30032354*	20046455A	

6.5.2 Case Assembly (NHW700-160SE/180SE/199SE)

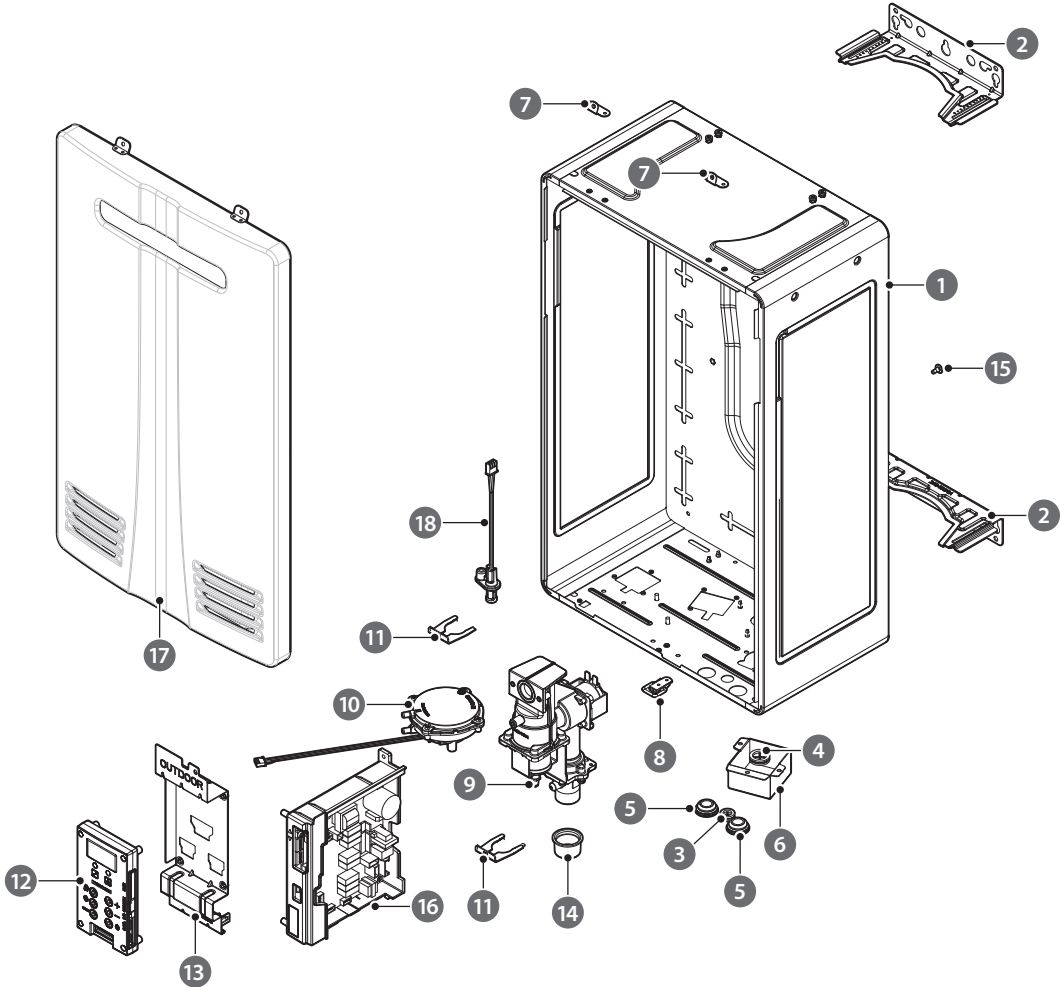

#	Description	Service Part #	Part #	Remark
1	Case	-	20047112B	120SE, 160SE
		-	20046059B	180SE, 199SE
2	Case Bracket	-	20048190B	
3	Rubber Cap	20006973*	20006973B	
4		20025127*	20025127A	
5		20029318*	20029318A	
6	Junction Box	-	20046065B	
7	Front Cover Bracket	-	20024042A	
8	External Base Toggle Latch	-	20007514B	
9	Gas Control Valve	30022125*	30031342A	
10	Air Pressure Sensor	30010238*	30010238B	
11	Pipe Clip	20045992*	20045992A	
12	Front Panel	30030640*	30022765C	
13	Front Panel Bracket	-	20045994A	
14	Pipe Cap	-	20012835A	
15	Rubber Seal Plug	-	20036041A	
16	PCB	30030638*	30030165A	
17	External Cover	30032355*	30022752A	
18	Anti-Freeze Sensor Assembly	30024489*	30024489A	

6.5.3 Case Assembly (NHW700-160AI/180AI/199AI)

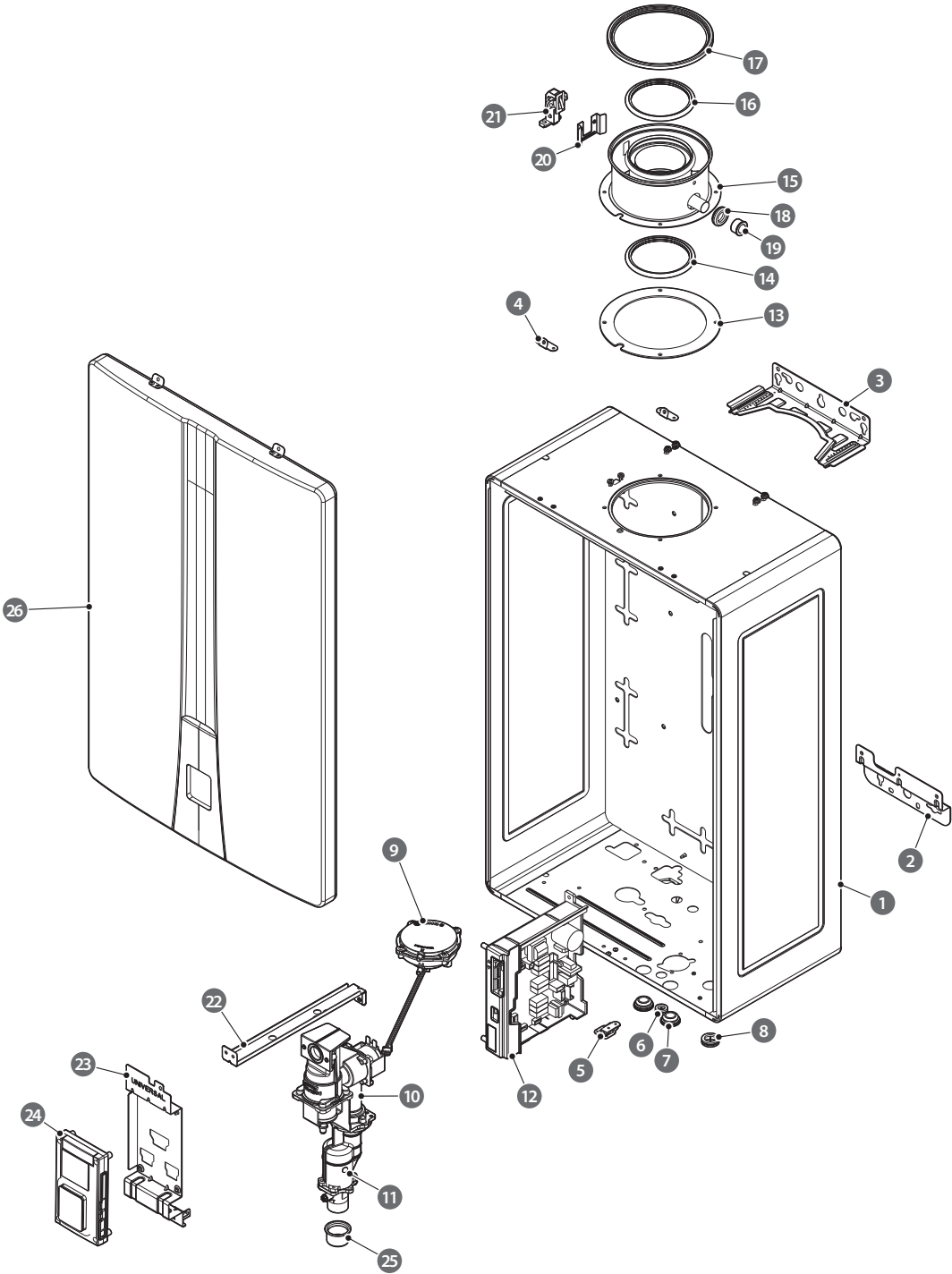

#	Description	Service Part #	Part #	Remark	
1	Case	-	20057546A	160AI	
		-	20057548A	180AI, 199AI	
2	Case Bracket (Lower)	-	20057580A		
3	Case Bracket (Upper)	-	20048190B		
4	Front Cover Bracket	-	20024042A		
5	External Base Toggle Latch	-	20007514B		
6	Rubber Cap	20006973*	20006973B		
7		20025127*	20025127A		
8		20029318*	20029318A		
9	Air Pressure Sensor	30010238*	30010238B		
10	Gas Valve	30022125*	30029845A		
11	Gas Valve Adapter	20057354*	20057354A		
12	PCB	30030638*	30030165A		
13	Exhaust Gasket	30022669*	20047330A		
14	Exhaust Rubber Packing		20046640A		
15	Intake Exhaust Pipe		20052298A		
16	Exhaust Rubber Packing		20046640A		
17	Intake Gasket		20046639A		
18	Condensate Drain Gasket		20046641A		
19	Condensate Drain Cap		20046642A		
20	VID Sensor Bracket		20048967A		
21	VID Sensor		30024038A		
22	Front Panel Support Bracket		-	20057369A	
23	Front Panel Bracket		-	20045993A	
24	Front Panel	30030639*	30022766B		
25	Pipe Cap	-	20012835A		
26	Front Cover	30030636*	30029816A		

6.5.4 Case Assembly (NHW700-160AE/180AE/199AE)

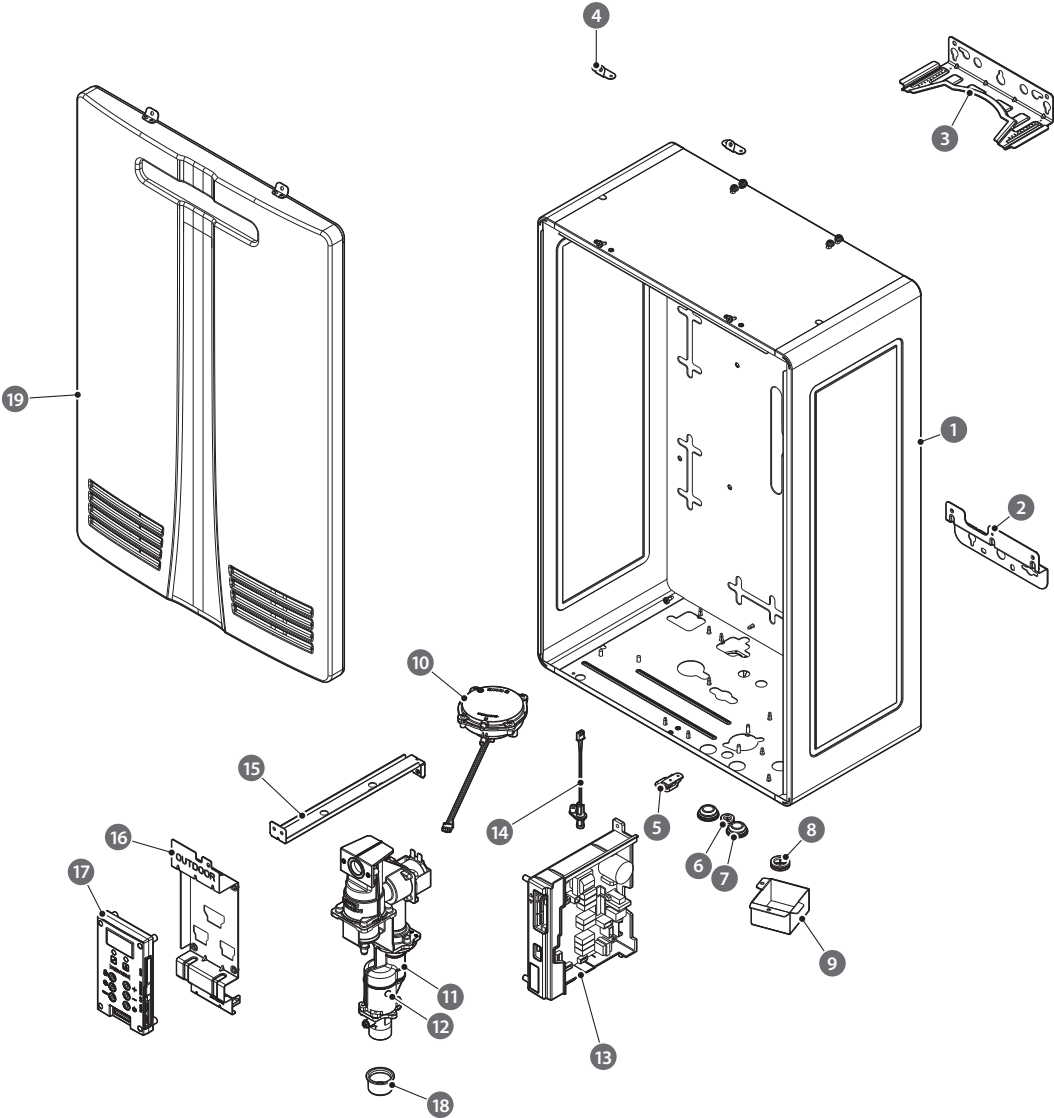

#	Description	Service Part #	Part #	Remark
1	Case	-	20057547A	160AI
		-	20057549A	180AI, 199AI
2	Case Bracket (Lower)	-	20057580A	
3	Case Bracket (Upper)	-	20048190B	
4	Front Cover Bracket	-	20024042A	
5	External Base Toggle Latch	-	20007514B	
6	Rubber Cap	20006973*	20006973B	
7		20025127*	20025127A	
8		20029318*	20029318A	
9	Junction Box	-	20061726A	
10	Air pressure Sensor	30010238*	30010238B	
11	Gas Valve	30029811*	30029845A	
12	Gas Valve Adapter	20057354*	20057354A	
13	PCB	30030638*	30030165A	
14	Freeze Protection Sensor	30024489*	30024489A	
15	Front Panel Support Bracket	-	20057369A	
16	Front Panel Bracket	-	20045993A	
17	Front Panel	30030640*	30022765A	
18	Pipe Cap	-	20012835A	
19	Front Cover	30030637*	30029817A	

6.5.5 Burner Assembly (NHW700-160SU/180SU/199SU)

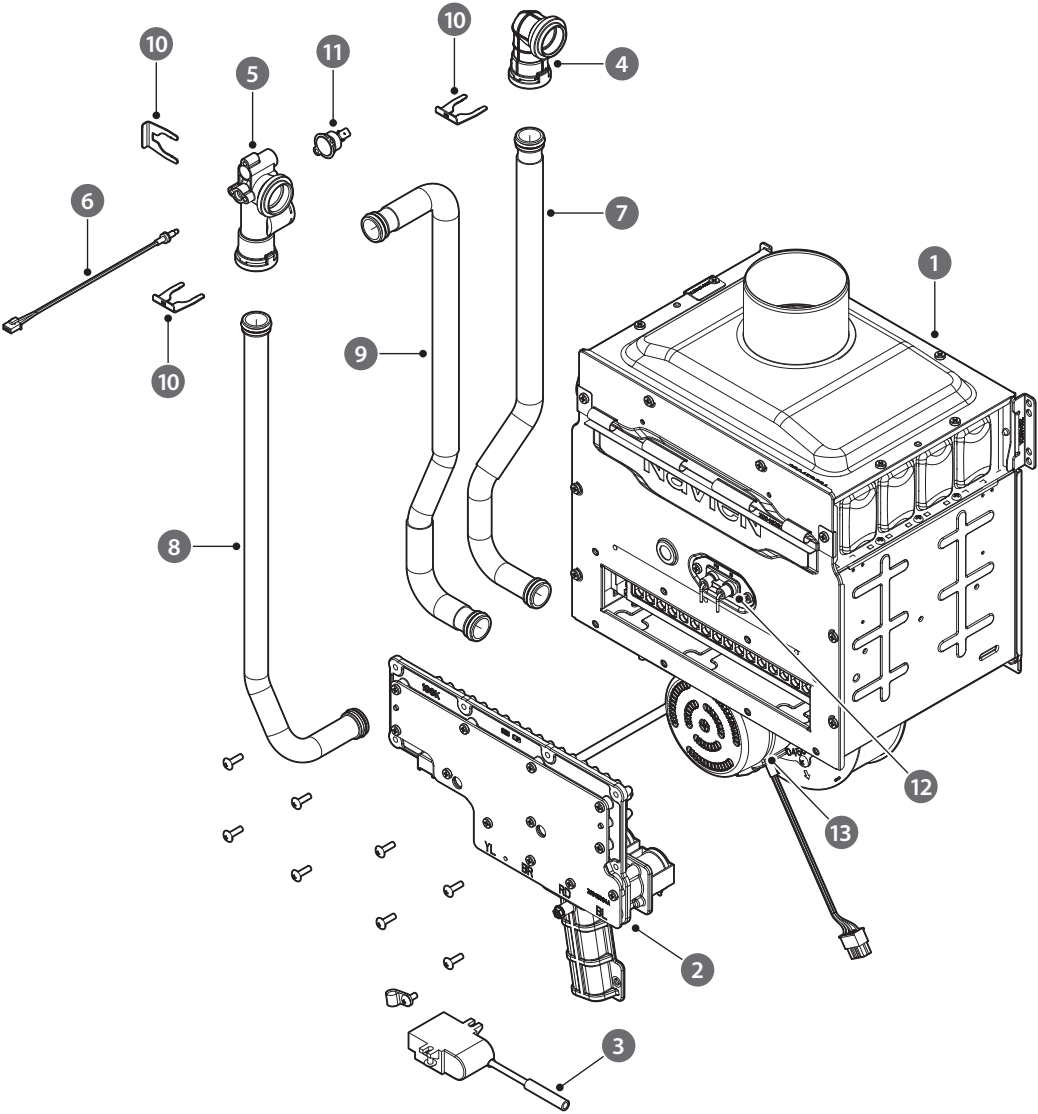

#	Description	Service Part #	Part #	Remark
1	Heat Exchanger Assembly	30032360*	30030237A	160SU
		30032358*	30030238A	180SU, 199SU
2	Gas Manifold	30030545*	30031335A	LNG; 160SU
		30030547*	30031337A	LNG; 180SU, 199SU
		30030546*	30031336A	LPG; 160SU
		30030548*	30031338A	LPG; 180SU, 199SU
3	Ignition Transformer	30023297*	30023297A	
4	Heat Exchanger Inlet Adapter	20045990*	20045990A	
5	Heat Exchanger Outlet Adapter	20045991*	20045991A	
6	Outlet Temperature Sensor	30015178*	30015178A	
7	Inlet Pipe	30022890*	30022890A	160S (U/E Both)
		30022711*	30022711A	180/199 (U/E Both)
8	Outlet Pipe	30022891*	30022891A	160S (U/E Both)
		30022712*	30022712A	180/199 (U/E Both)
9	Mixing Pipe	30022892*	30022892A	160S (U/E Both)
		30022713*	30022713A	180/199 (U/E Both)
10	Pipe Clip	20045992*	20045992A	
11	High Limit Switch	30002577*	30002577A	
12	Flame Rod Assembly	30022787*	30022787B	
13	Fan Assembly	30030134*	30030134A	160SU
		30030133*	30030133A	180SU, 199SU

6.5.6 Burner Assembly (NHW700-160SE/180SE/199SE)

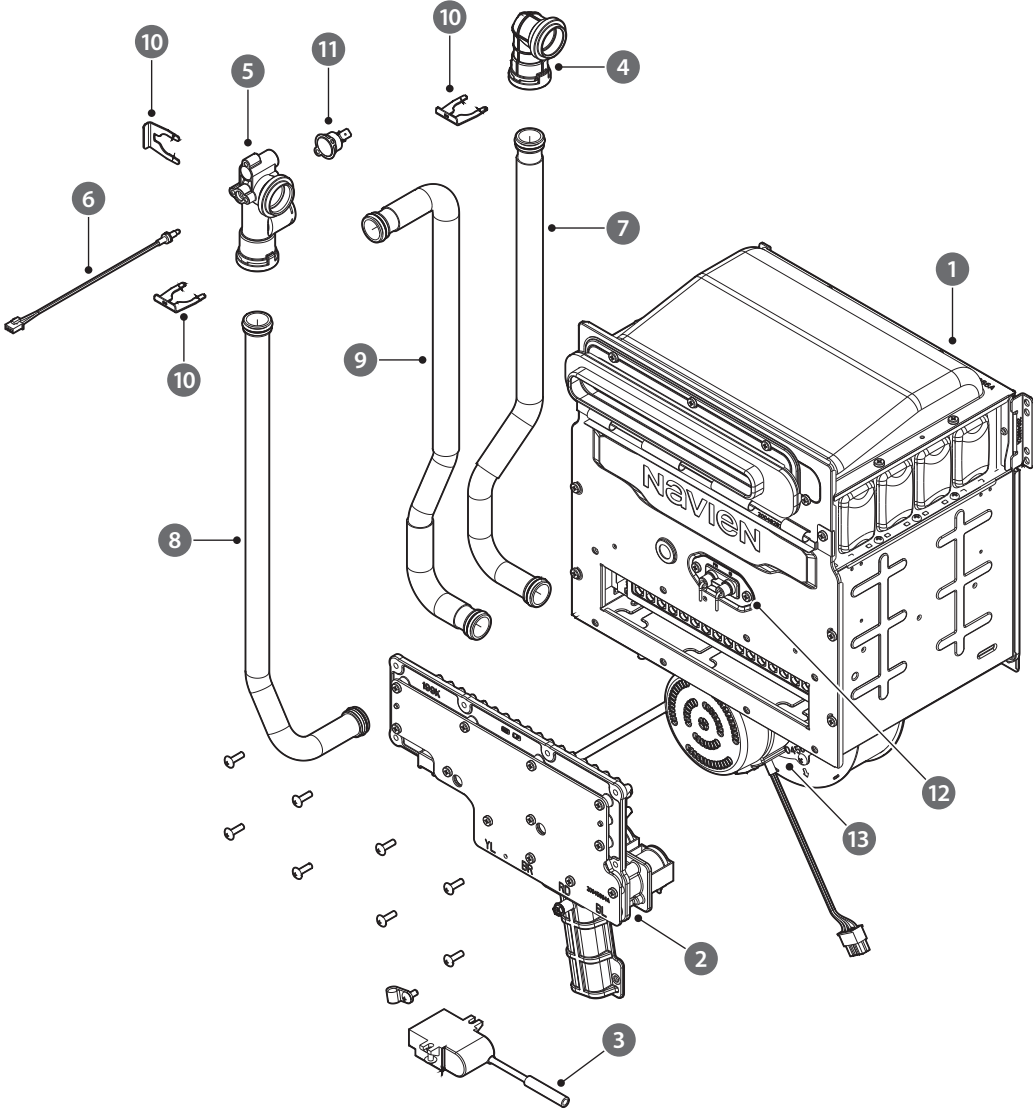

#	Description	Service Part #	Part #	Remark
1	Heat Exchanger Assembly	30032359*	30031377A	160SE
		30032357*	30031378A	180SE, 199SE
2	Gas Manifold	30030545*	30031335A	LNG; 160SE
		30030547*	30031337A	LNG; 180SE, 199SE
		30030546*	30031336A	LPG; 160SE
		30030548*	30031338A	LPG; 180SE, 199SE
3	Ignition Transformer	30023297*	30023297A	
4	Heat Exchanger Inlet Adapter	20045990*	20045990A	
5	Heat Exchanger Outlet Adapter	20045991*	20045991A	
6	Outlet Temperature Sensor	30015178*	30015178A	
7	Inlet Pipe	30022890*	30022890A	160S (U/E Both)
		30022711*	30022711A	180/199 (U/E Both)
8	Outlet Pipe	30022891*	30022891A	160S (U/E Both)
		30022712*	30022712A	180/199 (U/E Both)
9	Mixing Pipe	30022892*	30022892A	160S (U/E Both)
		30022713*	30022713A	180/199 (U/E Both)
10	Pipe Clip	20045992*	20045992A	
11	High Limit Switch	30002577*	30002577A	
12	Flame Rod Assembly	30022787*	30022787B	
13	Fan Assembly	30022990*	30022990A	160SE
		30022770*	30022770A	180SE, 199SE

6.5.7 Burner Assembly (NHW700-160AI/180AI/199AI)

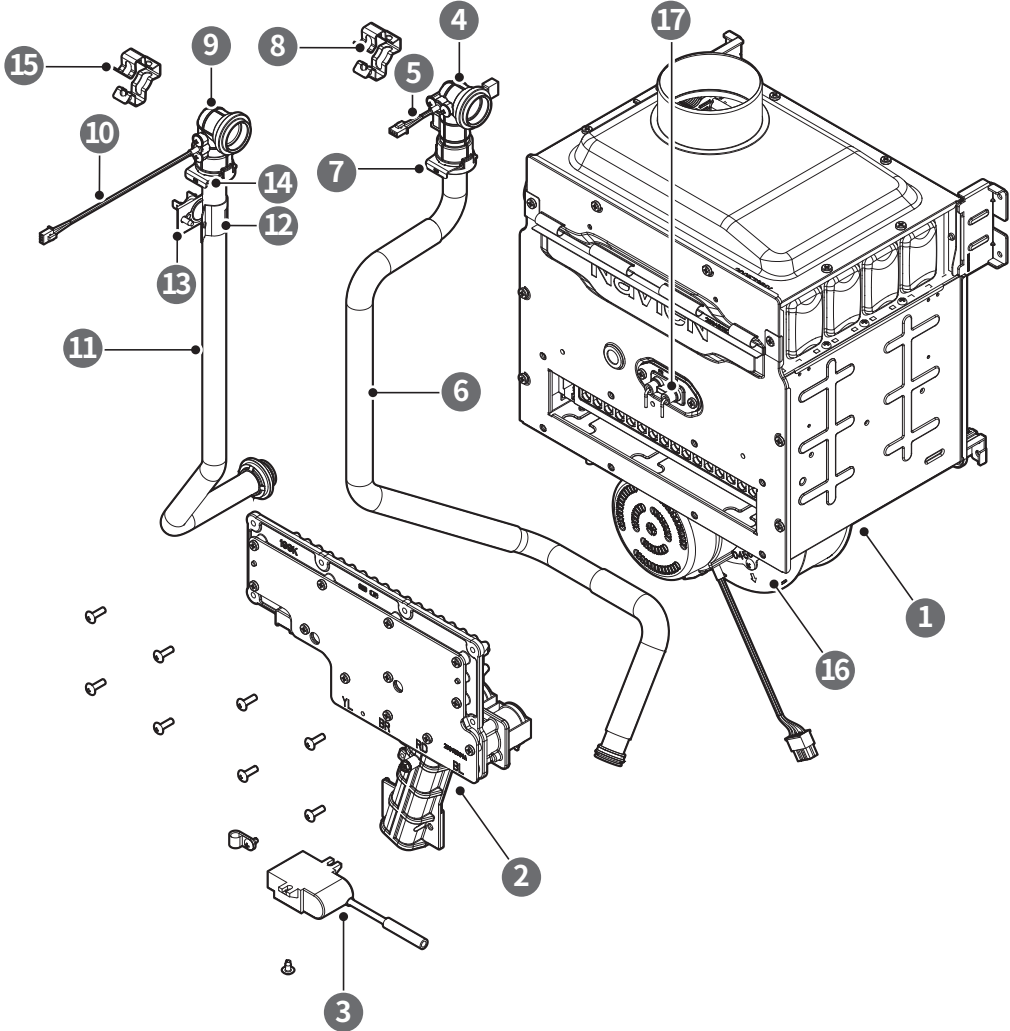

#	Description	Service Part #	Part #	Remark
1	Heat Exchanger Assembly	30030641*	30029771A	160AI
		30030643*	30029787A	180AI, 199AI
2	Gas Manifold	30030551*	20060738A	LNG; 160AI
		30030553*	20060740A	LNG; 180AI, 199AI
		30030552*	20060739A	LPG; 160AI
		30030554*	20060741A	LPG; 180AI, 199AI
3	Ignition Transformer	30023297*	30023297A	
4	Water Flow Sensor	30029799*	30031591A	
5	Inlet Temperature Sensor	30008366*	30008366A	
6	Inlet Pipe	30029798*	30029798A	
7	Clip	20045992*	20045992A	
8	Fastener	20007859*	20007859A	
9	Heat Exchanger Outlet Adapter	30029802*	30029802A	
10	Outlet Temperature Sensor	30015178*	30015178A	
11	Outlet Pipe	30029800*	30029800A	
12	Clamp	-	20027025A	
13	High Limit Switch	30002577*	30002577A	
14	Clip	20045992*	20045992A	
15	Fastener	20007859*	20007859A	
16	Fan Assembly	30030136*	30030136A	160AI
		30030135*	30030135A	180AI, 199AI
17	Flame Rod Assembly	30022787*	30022787B	

6.5.8 Burner Assembly (NHW700-160AE/180AE/199AE)

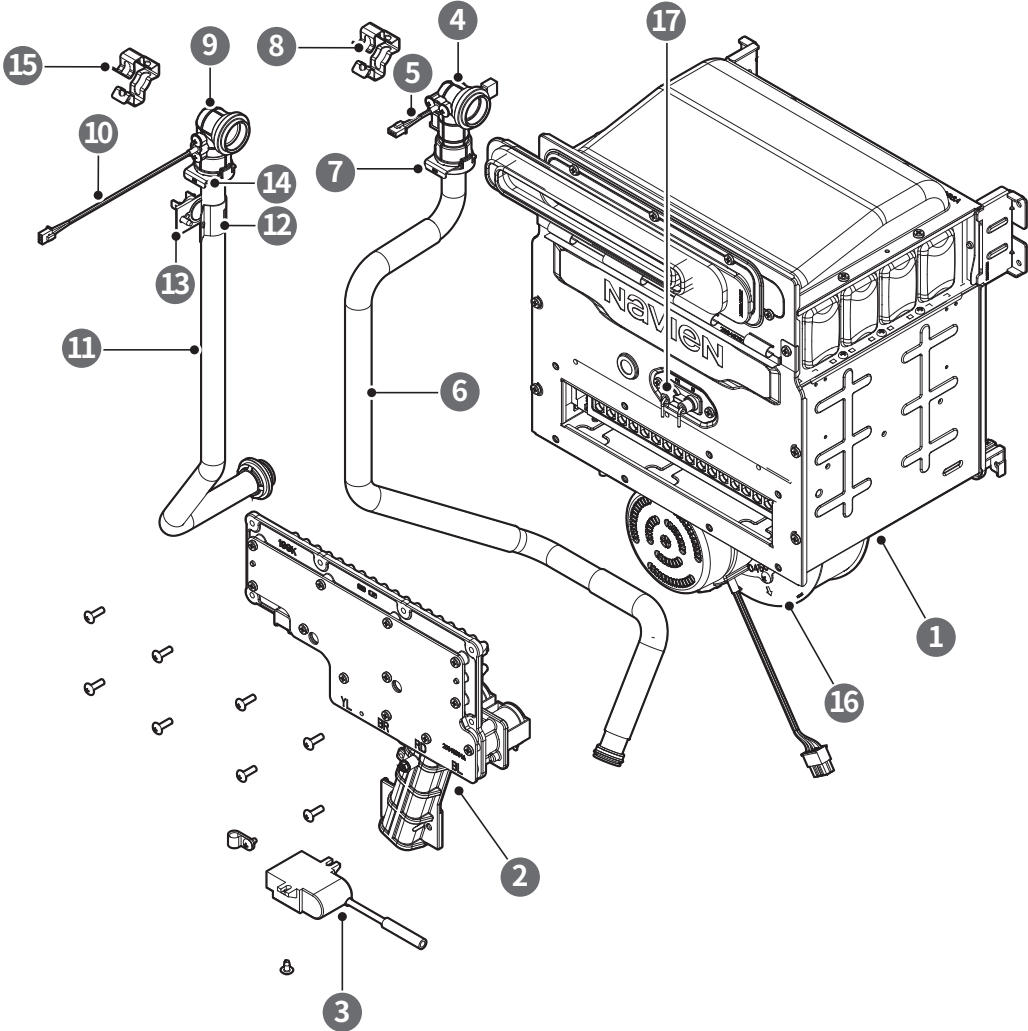

#	Description	Service Part #	Part #	Remark
1	Heat Exchanger Assembly	30030642*	30029772A	160AE
		30030644*	30029788A	180AE, 199AE
2	Gas Manifold	30030551*	20060738A	LNG; 160AE
		30030553*	20060740A	LNG; 180AE, 199AE
		30030552*	20060739A	LPG; 160AE
		30030554*	20060741A	LPG; 180AE, 199AE
3	Ignition Transformer	30023297*	30023297A	
4	Water Flow Sensor	30029799*	30031591A	
5	Inlet Temperature Sensor	30008366*	30008366A	
6	Inlet Pipe	30029798*	30029798A	
7	Clip	20045992*	20045992A	
8	Fastener	20007859*	20007859A	
9	Heat Exchanger Outlet Adapter	30029802*	30029802A	
10	Outlet Temperature Sensor	30015178*	30015178A	
11	Outlet Pipe	30029800*	30029800A	
12	Clamp	-	20027025A	
13	High Limit Switch	30002577*	30002577A	
14	Clip	20007859*	20007859A	
15	Fastener	20007859*	20007858A	
16	Fan Assembly	30030138*	30030138A	160AE
		30030137*	30030137A	180AE, 199AE
17	Flame Rod Assembly	30022787*	30022787B	

6.5.9 Water Assembly (NHW700-SE/SU Models)

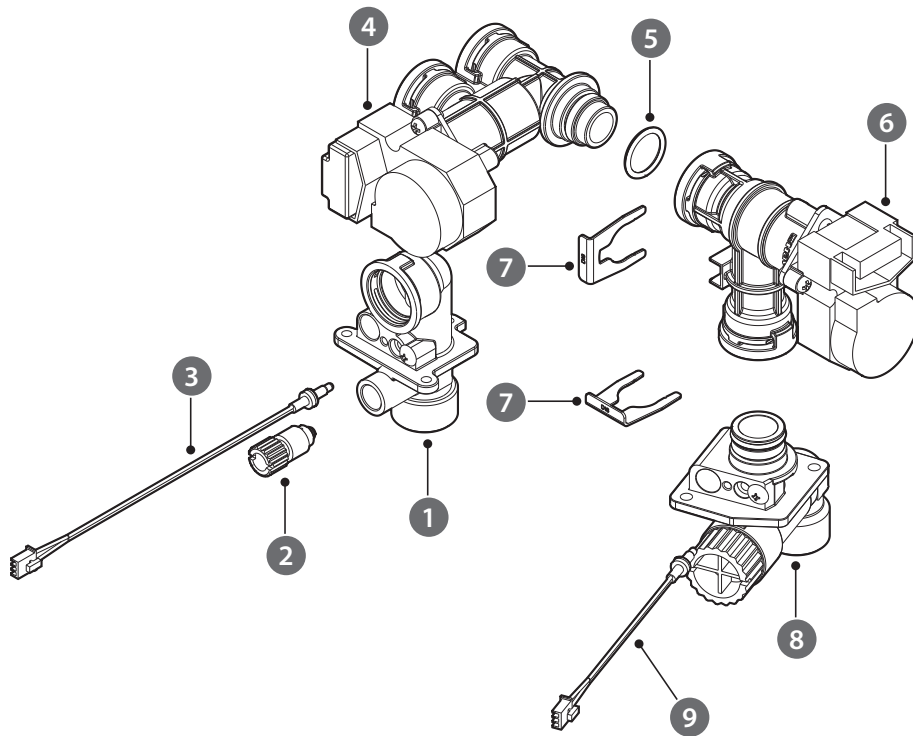

#	Description	Service Part #	Part #	Remark
1	Hot Water Supply Adapter	30030380*	30030380A	
2	Drain Cock	30008630*	30008630D	
3	DHW Outlet Temperature Sensor	30015178*	30015178A	
4	Mixing Valve	30022124*	30022124A	
5	O-Ring	20006947*	20006947A	
6	Water Adjustment Valve	30022123*	30022123A	
7	Pipe Clip	20045992*	20045992A	
8	Direct Water Inlet Adapter	30030379*	30030379A	
9	DHW Outlet Temperature Sensor	30008366*	30008366A	

6.5.10 Water Assembly (NHW700-AI/AE Models)

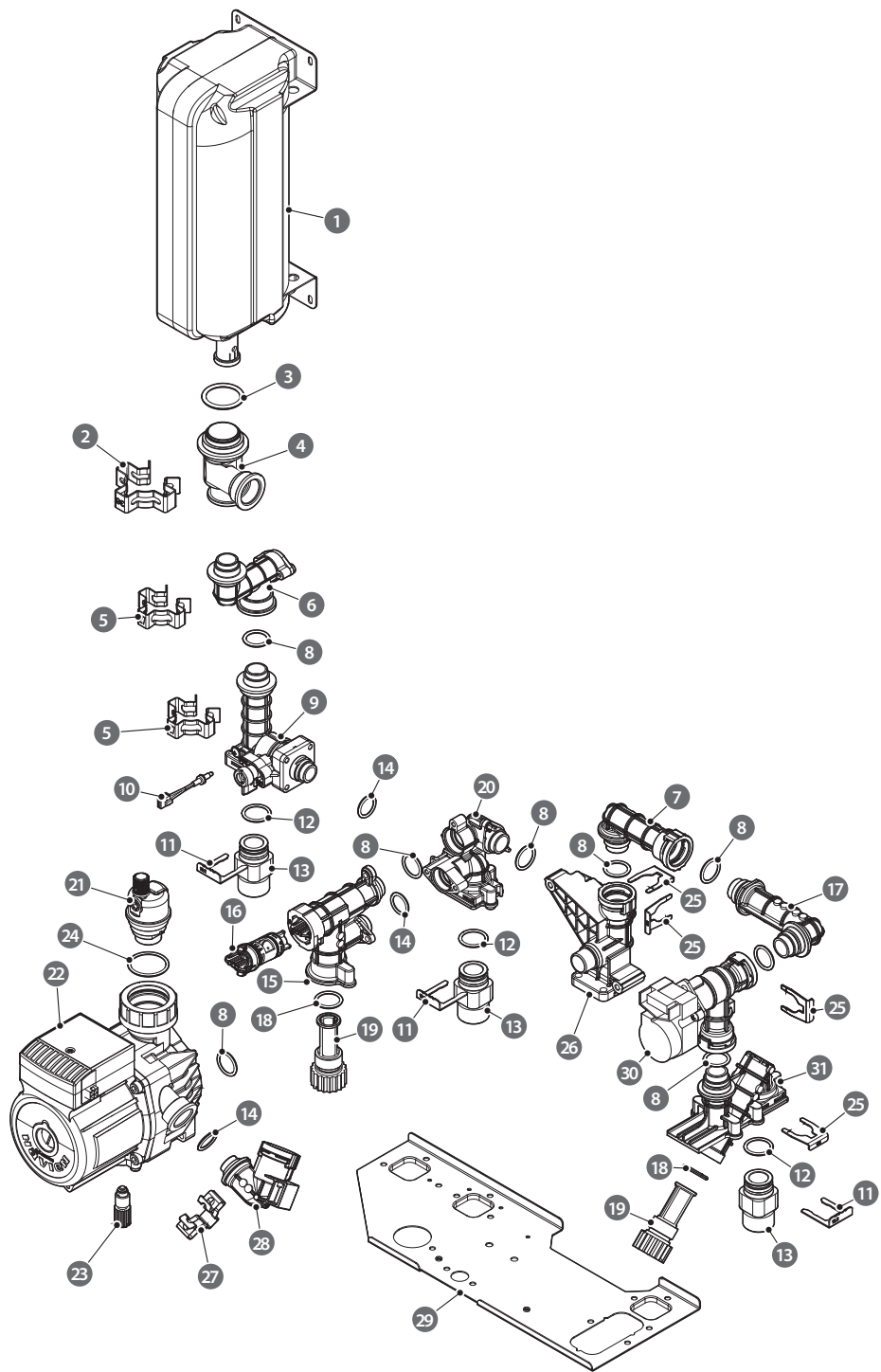

#	Description	Service Part #	Part #	Remark
1	Buffer Tank	30016125*	30016125A	
2	Fastener	20017724*	20017724A	
3	O-Ring	20017923*	20017923A	
4	Buffer Tank Adapter A	20035697*	20035697A	
5	Fastener	20017726*	20017726A	
6	Buffer Tank Adapter B	30029809*	30029809A	
7	Pump Connect Adapter	20048418*	20048418A	
8	O-Ring (P18)	20006947*	20006947A	
9	Hot Water Outlet Adapter	20017729*	30008338A	
10	Thermistor	30008366*	30008366A	
11	Clip	20007733*	20007733B	
12	O-Ring (P20)	20017212*	20017212A	
13	Cold Water Inlet Adapter	20024496*	20024496A	
14	O-Ring (P16)	20017210*	20017210A	
15	Check Valve Adapter	20048412*	20048412A	
16	Check Valve	30024442*	30008359B	
17	WAV Outlet Adapter	20048415*	20048415A	
18	O-Ring (P19)	20017211*	20017211A	
19	Water Filter	30008171*	30008171A	
20	Return Connect Adapter	20048405*	20048405A	
21	Pump Air Separator	30010780*	30013056A	
22	Circulation Pump		30008355D	
23	Drain Plug		30008630D	
24	O-Ring (P30)		20022322A	
25	Clip	20045992*	20045992A	
26	Pump Inlet Adapter	20048414*	20048414A	
27	Fastener	20007859*	20007859A	
28	Pump Outlet Adapter	20048419*	20048419B	
29	Bracket	-	20048396A	
30	Water Adjust Valve	30024183*	30024183A	
31	Cold Water Adapter	20048454*	20048454A	

6.6 Installation Check list

After installing the water heater, review the following checklist. You should be able to answer “Yes” to all of the items in the checklist. If not, review the appropriate sections to complete the installation. To troubleshoot any operational problems refer to “Troubleshooting” in the User’s Information Manual.

If you have additional questions or need assistance with installation, contact Technical Support at 1-800-519-8794 or 1-949-420-0420, or refer to the technical support section of Navien’s website (www.navieninc.com).

Installing the Water Heater	Yes	No
Have you maintained the required clearances from building openings and intake air vents?		
Have you minimized the distance between the water heater and the vent termination?		
Have you minimized the distance between the water heater and major fixtures?		
Have you maintained the proper service and maintenance clearances?		
Is the make-up air supply sufficient for proper operation?		
Is the make-up air supply free from dust, dirt, corrosive elements, and flammable vapors?		
Is the water heater and vent piping clear of combustible materials, including clothing, cleaning materials, and rags?		

Connecting the Gas Supply	Yes	No
Does the gas supply match the type specified on the water heater’s rating plate?		
Is the gas line at least 1/2 in or 3/4 in ID (Inner Diameter)?		
Is the gas supply line sufficient in length and diameter to deliver the required BTUs?		
Have you measured the pressure of the gas supply line?		
Is the gas supply pressure within the recommended ranges specified in this manual?		
Is the gas supply line equipped with a manual full port valve?		
Have you tested the gas line pressure and all fittings for leaks?		
Has the gas company inspected the installation, if required?		

Connecting the Water Supply	Yes	No
Is the water supply pressure sufficient (greater than 40 PSI)?		
Have you installed shut off valves on the inlet and outlet to facilitate cleaning of the inlet water filter?		
Have you bled the air out at each fixture?		
Have you checked each fixture to ensure hot water is being supplied?		
Have you cleaned the inlet water filter?		
If you installed a recirculation line, have you insulated the hot water pipes and the return line?		

Connecting a Pressure Relief Valve	Yes	No
Have you installed an approved pressure relief valve on the water heater?		
Does the rating of the pressure relief valve match or exceed the maximum BTU rating of the water heater?		
Is the pressure relief valve at least $\frac{3}{4}$ in in diameter?		
Have you installed the pressure relief valve on the hot water outlet pipe near the water heater?		
Have you installed a discharge drain tube from the pressure relief valve to within 6–12 in (150–300 mm) of the floor?		

Venting the Water Heater	Yes	No
Have you ensured that there are proper clearances around the vent and air intakes?		
Have you ensured that only the approved vent materials listed in this manual are used as venting for the water heater?		
Have you ensured that 1.3" of vent was inserted into the water heater vent collar then affixed with the included screws?		
Is the vent sloped upward toward the vent termination at a rate of $\frac{1}{4}$ in per foot (2 % grade)?		
Are all vent runs properly supported?		
Have you properly supported the vent termination?		
Have you properly sealed all air intake and exhaust joints, from the flue collar to the to the vent termination?		
Have you installed an end cap on the vent pipe?		
Have you checked the venting for leaks?		
Is the vent termination at least 12 in (300 mm) above the exterior grade?		
Have you ensured that sufficient make-up air is available?		
Is the total vent length within the maximum vent length restriction?		

Connecting the Power Supply	Yes	No
Is the supplied voltage 110-120 V AC?		
Is the water heater plugged into a properly grounded outlet?		
If you have made a direct power supply connection, have you installed a power switch to facilitate end-user maintenance?		
Have you checked the polarity of the electrical connection?		
Is the system properly set up for cascade operation (Main and Sub water heaters), if applicable?		

Setting the DIP Switches	Yes	No
Have you verified the positions of all DIP switches on the circuit board?		
Have you verified the positions of all DIP switches on the front panel?		

Operating the Water Heater	Yes	No
Have you shown the owner how to clean the inlet water filter?		
Have you given the Installation Manual and User's Information Manual to the owner for future reference?		
Have you shown the owner how to shut off the gas in case of an emergency?		

6.7 Navien H2Air Add-on Controller Kit (Optional)

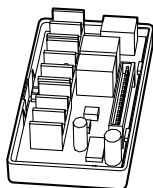

The Navien H2Air is an add-on controller for the water heater. It adds input and output functions to the water heater for a combination application where space heating and domestic hot water (DHW) are supplied simultaneously. With this add-on controller, a thermostat (1 or 2-stage) and an outdoor sensor can be installed along with a hydronic air handler to add space heating functionality to the system.

6.7.1 Basic Principles

The following diagram shows the basic operation of the heater system with the Navien H2Air add-on controller.

NOTICE

Do not configure the system for DHW recirculation when it is configured to run an air handler using the H2Air add-on controller. DHW recirculation and Navien H2Air configurations cannot be used at the same time.

System Diagram for NHW700-SE/SU Models

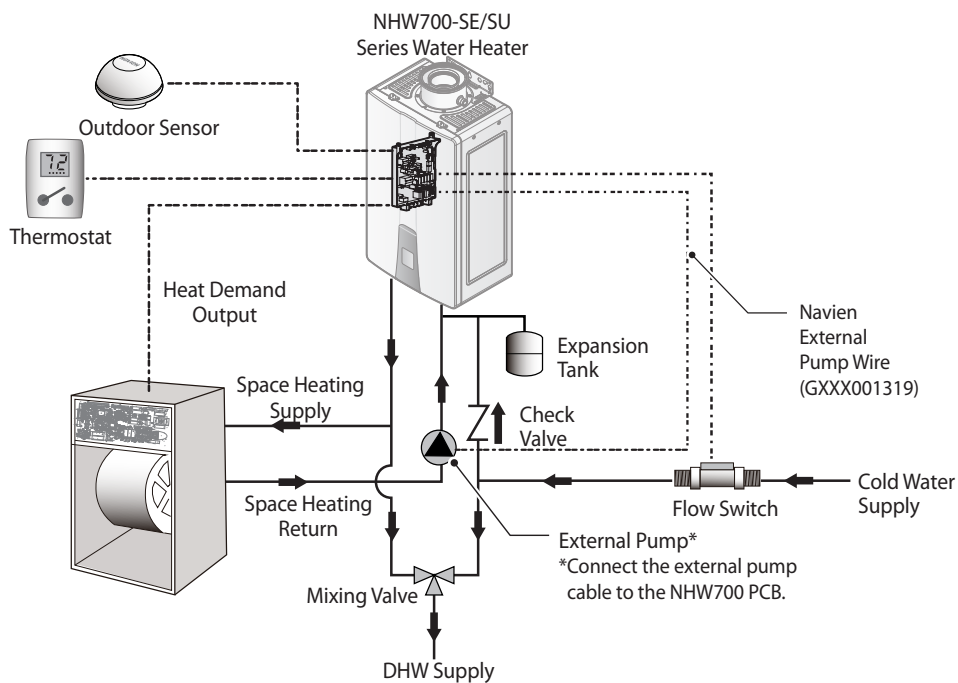

Note

Use a properly sized pump to allow 3-4 GPM of flow through the water heater. Refer to the Appendix for the pressure loss information on page 70.

For details, refer to the installation manual that is provided with the H2Air add-on controller kit.

System Diagram for NHW700-AI/AE Models

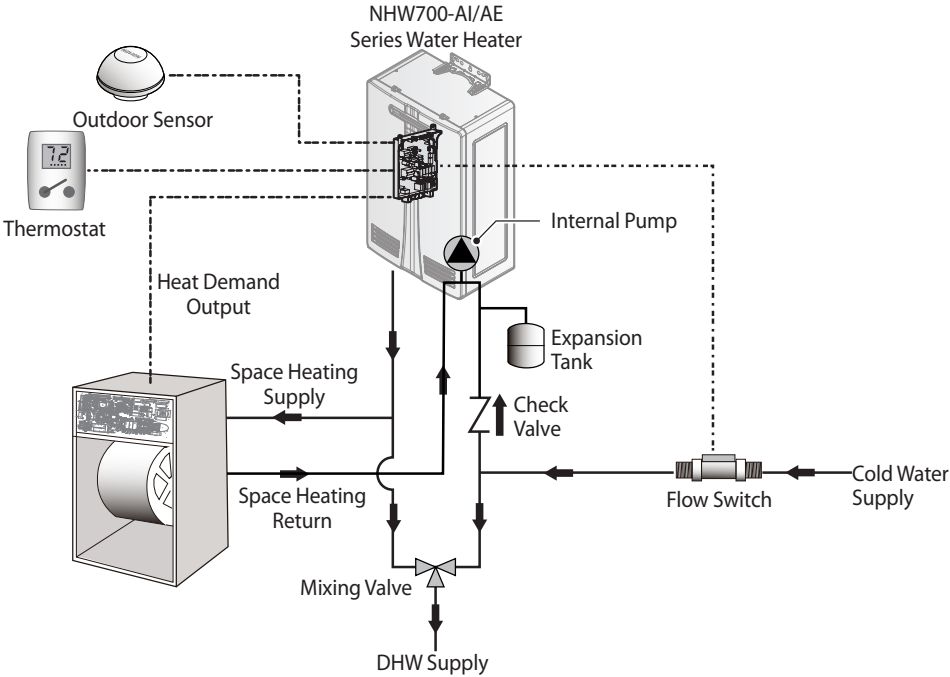

6.8 Requirements for the State of Massachusetts

NOTICE BEFORE INSTALLATION

This appliance must be installed by a licensed plumber or gas fitter in accordance with the Massachusetts Plumbing and Fuel Gas Code 248 CMR Sections 4.00 and 5.00.

IMPORTANT: In the State of Massachusetts (248 CMR 4.00 & 5.00)

For all side wall horizontally vented gas fueled equipment installed in every dwelling, building or structure used in whole or in part for residential purposes, including those owned or operated by the Commonwealth and where the side wall exhaust vent termination is less than seven (7) feet above finished grade in the area of the venting, including but not limited to decks and porches, the following requirements shall be satisfied:

1. INSTALLATION OF CARBON MONOXIDE DETECTORS. No installation or replacement of a vented gas appliance shall be permitted unless a battery powered or electrically hard wired carbon monoxide detector is present on the same floor as the appliance or on the next adjacent floor when the appliance is located in a crawl space unless the appliance is located in a detached, uninhabitable garage. For all residential dwellings, a carbon monoxide detector must also be present on each habitable level of the dwelling. These requirements shall not be deemed to waive any additional requirements imposed by M.G.L. c. 148 §26F1/2.
2. APPROVED CARBON MONOXIDE DETECTORS. Each carbon monoxide detector as required in accordance with the above provisions shall comply with NFPA 720 and be ANSI/UL 2034 listed and IAS certified.
3. SIGNAGE. Whenever any through-the-wall vent is installed less than seven feet above the finished grade, a metal or plastic identification plate shall be permanently mounted to the exterior of the building at a minimum height of eight feet above grade directly in line with the exhaust vent terminal. The sign shall read, in print size no less than 0.5 inches in size, "**GAS VENT DIRECTLY BELOW. KEEP CLEAR OF ALL OBSTRUCTIONS**".
4. INSPECTION. The state or local gas inspector of the side wall horizontally vented gas fueled equipment shall not approve the installation unless, upon inspection, the inspector observes carbon monoxide detectors and signage installed in accordance with the provisions of 248 CMR 5.09 and 5.12.

7. LIMITED WARRANTY NAVIEN, INC.

Effective Terms

This 15 year limited warranty on heat exchangers, 5 year limited warranty on parts, and 1 year Limited warranty on labor ("Warranty") covers defects in materials or workmanship when the Navien NHW700 Water Heater("Product") is installed by a properly licensed plumber or contractor and operated in strict compliance with the Installation & Operations manual procedures, subject to the terms within this Warranty document. Improper installation or use will void this Warranty. This Warranty runs from date of installation and extends to the original purchaser and subsequent owners, but only while the Product remains at the site of the original installation.

What is Covered?

Subject to the foregoing terms, Navien will repair or replace the covered Product or any part or component that is defective in materials or workmanship for a period of five (5) years in regard to parts and up to fifteen (15) Years in regard to the heat-exchanger for a Standard¹ or Controlled-Recirculation² installation in a Residential⁴ application. All repair parts must be genuine Navien parts. All repairs and replacements must be performed by an individual or servicing company that is properly licensed to do the type of repair.

When the Product is being used in an Uncontrolled-Recirculation³ installation in a Residential⁴ application, then the parts warranty will be reduced to three (3) years and the heat exchanger warranty to five (5) years as indicated in the Warranty Coverage Periods table.

When the Product is being used in an Standard¹ or Controlled-Recirculation² installation in a Combi⁴ or Commercial application, then the parts warranty will remain at five (5) years and the heat exchanger warranty will be reduced to five (5) years as indicated in the Warranty Coverage Periods table.

When the Product is being used in an Uncontrolled-Recirculation³ installation in a Combi⁴ or Commercial application, then the parts warranty will be reduced to three (3) years and the heat exchanger warranty to three (3) years as indicated in the Warranty Coverage Periods table.

Navien will pay labor charges for the warranty repair subject to Navien's prior written approval and in accordance with Navien's schedule of approved labor allowances for a period of one (1) year from the date of installation.

During the applicable warranty period, replacement of the Product or components may be authorized by Navien only. Navien does not authorize any person or company to assume for it any obligation or liability in connection with the replacement of the Product or its components. If it is determined that repair or replacement of a part, under warranty, is not possible, the Product will be replaced with a new Product having at least the same BTU capacity as the product at issue. The replacement component or product will be warranted only for the unexpired portion of the applicable warranty period for the original component or Product.

Warranty Coverage Periods				
Application		Labor Warranty	Parts Warranty	H/Ex Warranty
Residential ⁴	Standard ¹ or Cont-Recirc ²	1 year	5 years	15 years
	Uncont- Recirc ³	1 year	3 years	5 years
Commercial or Combi ⁴	Standard ¹ or Cont-Recirc ²	1 year	5 years	5 years
	Uncont- Recirc ³	1 year	3 years	3 years

⁴Applies only to single family, residential locations

¹ **Standard** means there is no recirculation being used

² **Controlled-Recirculation** means recirculation of the water through the water heater is controlled by either the water heater or an external aquastat.

³ **Uncontrolled-Recirculation** External pumps configured to circulate continuously through the water heater are subject to the uncontrolled recirculation warranty terms. An aquastat is the minimum pump control requirement for DHW or storage tank recirculation in order to maintain the full controlled recirculation warranty.

⁴ **Combi** refers to a combination potable water and space heating application.

Water Heaters cannot be use in space heating only applications or this warranty will be voided.

How do I get service?

You must contact the original installer of your Product. Your installer will need to contact Navien to report the issue. If the original installer cannot be identified or you no longer choose to use that service provider, you may choose any service provider who is properly licensed to complete the necessary repair. The installer and/or service provider must comply with Navien's warranty service and return policy procedures as available on Navien's website including contacting Navien's Technical Support Department at (800) 519-8794, option 2, prior to commencing any service.

Proof of the date of installation must be provided to Navien. At Navien's request, the defective Product or part must be returned to Navien. When the Product is installed in new construction, the date of installation shall be established as the date upon which the end-user takes title to the real property. If proof of the installation date is unavailable, then six months after the date of manufacture will be used.

Additional terms and conditions are continued on the reverse side.



Customer Name :	
Customer Address :	
Telephone :	Fax :
Email :	
Installer Name :	License No :
Installer Address :	
Place of Purchase :	
Model No :	
Serial No :	
Date of Purchase :	



Navien, Inc.
 20 Goodyear, Irvine, CA 92618
 Tel : 1-800-519-8794
 Fax : 949-420-0430
 www.navieninc.com

For instant warranty registration, please register your product online at www.navieninc.com

What is not covered?

Navien's Limited Warranty shall be void in the event of an occurrence of any of the following:

- Improper installation, including but not limited to failure to install in strict compliance with the Installation and Operation Manual, installation in violation of applicable rules, laws or building codes, inadequate water quality, condensate damage, improper venting, incorrect gas type, water pressure, improper conversion from Natural Gas source to Propane, improper conversion from Propane source to Natural Gas, reinstallation at another location, etc.
- Accident, abuse or misuse including but not limited to installation for non-recommended uses, failure to follow or comply with the User's Operational Manual, etc.
- Improper maintenance including but not limited to, scale buildup, vent blockage, failure to maintain, etc.
- Modification, alteration, addition of non-approved components, or misapplication of the Product in any manner.
- Any damage caused by local adverse conditions including but not limited to water quality, hard water deposits, lime or mineral build-up, operating in corrosive atmospheric elements, alterations in smell or taste of water that have an adverse reaction on the unit, etc.
- Damage or problems caused by gas flow issues, electrical surges, flooding, fire, freezing, abnormal external temperature, force majeure, riot, act of war, or any acts of God.
- Performance problems caused by improper sizing of the boiler, the gas supply line, the venting connection, combustion air openings, electric service voltage, wiring, fusing or any other components, parts or specifications.
- Vibration and noise unless caused by a defect in materials or workmanship. Any other causes other than defects in materials or workmanship.
- Operating the Product at water temperatures outside the factory calibrated temperature limits and/or exceeding the maximum setting of the high limit control.
- Subjecting the heat exchanger to pressures or firing rates greater or lesser than those shown on the rating plate or removal of or alteration to the rating plate.
- Installation at any location outside the United States.
- Improper conversion from natural gas to liquid propane gas or liquid propane gas to natural gas or attempt to operate with a type of gas not specified for the boiler.
- Accidental or intentional damage.
- Operating the Product when it is not supplied with potable water at all times.

There is no warranty on any Product purchased through the internet or from any installer that obtained the Product from a supplier or distributor not authorized by Navien.

Warranty Limitations

EXCEPT AS EXPRESSLY PROVIDED HEREIN, THERE ARE NO OTHER WARRANTIES, EXPRESSED OR IMPLIED, INCLUDING, BUT NOT LIMITED TO WARRANTIES OR MERCHANTABILITY OR FITNESS FOR A PARTICULAR PURPOSE, WHICH EXTEND BEYOND THE DESCRIPTION OF THE WARRANTY HEREIN AND FURTHER NAVIEN SHALL NOT BE LIABLE FOR INDIRECT, INCIDENTAL, SPECIAL, CONSEQUENTIAL, PUNITIVE OR OTHER SIMILAR DAMAGES THAT MAY ARISE, INCLUDING LOST PROFITS, DAMAGE TO A PERSON OR PROPERTY, LOSS OF USE, INCONVENIENCE, OR LIABILITY ARISING FROM IMPROPER INSTALLATION, SERVICE OR USE OF THE PRODUCT. ANY IMPLIED WARRANTIES OF MERCHANTABILITY AND FITNESS ARISING UNDER STATE LAW ARE LIMITED IN DURATION TO THE PERIOD OF COVERAGE PROVIDED BY THIS WARRANTY, UNLESS THE PERIOD PROVIDED BY STATE LAW IS LESS.

No one is authorized to make any other warranties on behalf of Navien. Some states do not allow the exclusion or limitation of incidental or consequential damages, or how long an implied warranty lasts, so the above limitation may not apply to you.

This Limited Warranty gives you specific legal rights and you may also have other rights which vary from state to state.

Rev. 9.20.2023

Retain this document for future reference.



Memo

Installation Manual

NHW700 Non-Condensing Water Heaters

Getting Service

If your water heater requires service:

- All repairs require pre-authorization by Technical Support.
- Request for your installer or any licensed professional to contact Technical Support at 1-800-519-8794 Option 2 once at the installation site.
- A short list of independent service providers in your area can be found on the website: www.navieninc.com/installers.
- Contact a licensed professional for the affected system (for example, a plumber, gas fitter, or electrician).

When you contact Technical Support, please have the following information at hand:

- Model number
- Serial number
- Date purchased
- Installation location and type
- Error code, if any appears on the front panel display

Version: 1.1 (February, 2024)



800.519.8794 | www.navieninc.com
20 Goodyear Irvine, CA 92618