

NPF Series



Condensing Hydro-furnaces



Water Fill



Introducing the new NPF Hydro-furnace



NPF700 Horizontal



NPF700 Upflow



Elevating comfort with advanced hydronic heating technology

Navien's legacy of hydronic heating innovation has established us as the leader in condensing tankless water heaters and wall-hung boilers across North America. Our stainless steel heat exchanger technology in our water heaters and boilers now power our hydro-furnace.



Heating air with warm water is so comfortable

In conventional gas furnaces the combustion heat exchanger is located in the conditioned airstream, subjecting the air to high temperatures that can deplete humidity levels. In contrast, the NPF Hydro-furnace heats water in a separate sealed heat exchanger, isolating it from the airstream. The heated water is pumped through a heat exchanger in the airstream to heat the air for the home, ensuring precise system control, safe heating, quiet operation, and minimal impact on humidity levels.

NPF Hydro-furnace

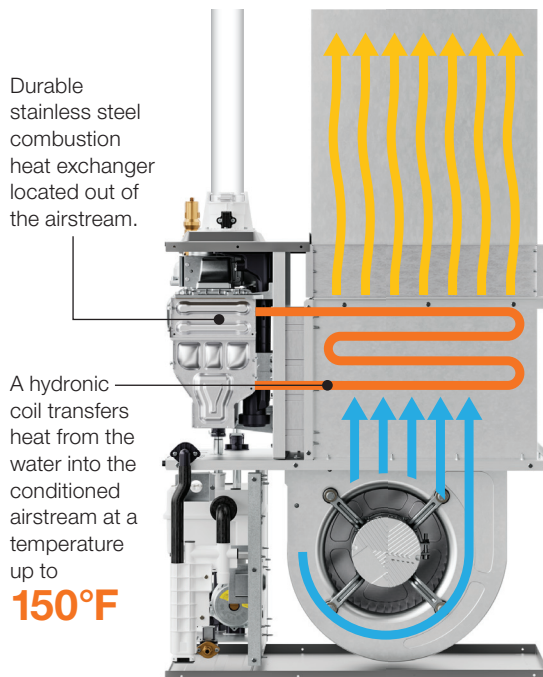

Conventional furnace

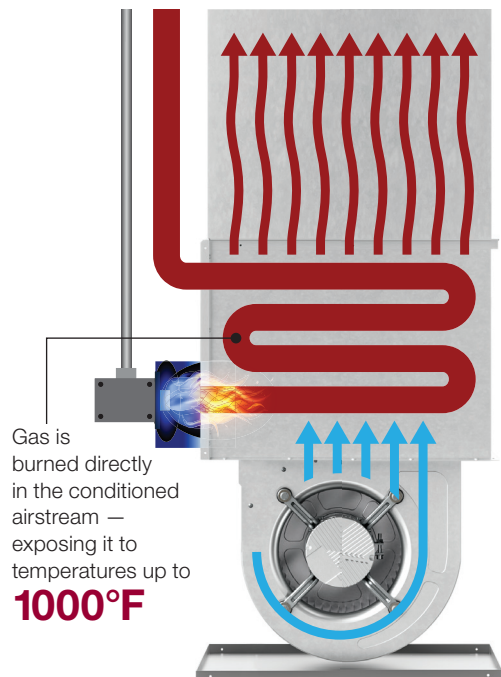

Our unique hydronic forced-air heating design keeps combustion in a separate, fully enclosed compartment for safe and quiet comfort.

High-efficient condensing technology allows for cost-saving PVC venting. Also, all models are equipped with a Vent Installation Detector (VID) for added safety during installation and maintenance.

The innovative stainless steel combustion heat exchanger is the heart of the Hydro-furnace. Positioned outside of the airstream, achieves an impressive 97% heating efficiency and is Ultra Low NOx compliant.

Easy access manual fill reservoir.

EZNav™ user-friendly backlit control panel provides hassle-free comprehensive operational data and diagnostics.

Industry-leading Variable Capacity Control System of 15% to 100%, which includes our ECM variable speed blower motor. This system optimizes energy savings and enhanced forced air comfort.

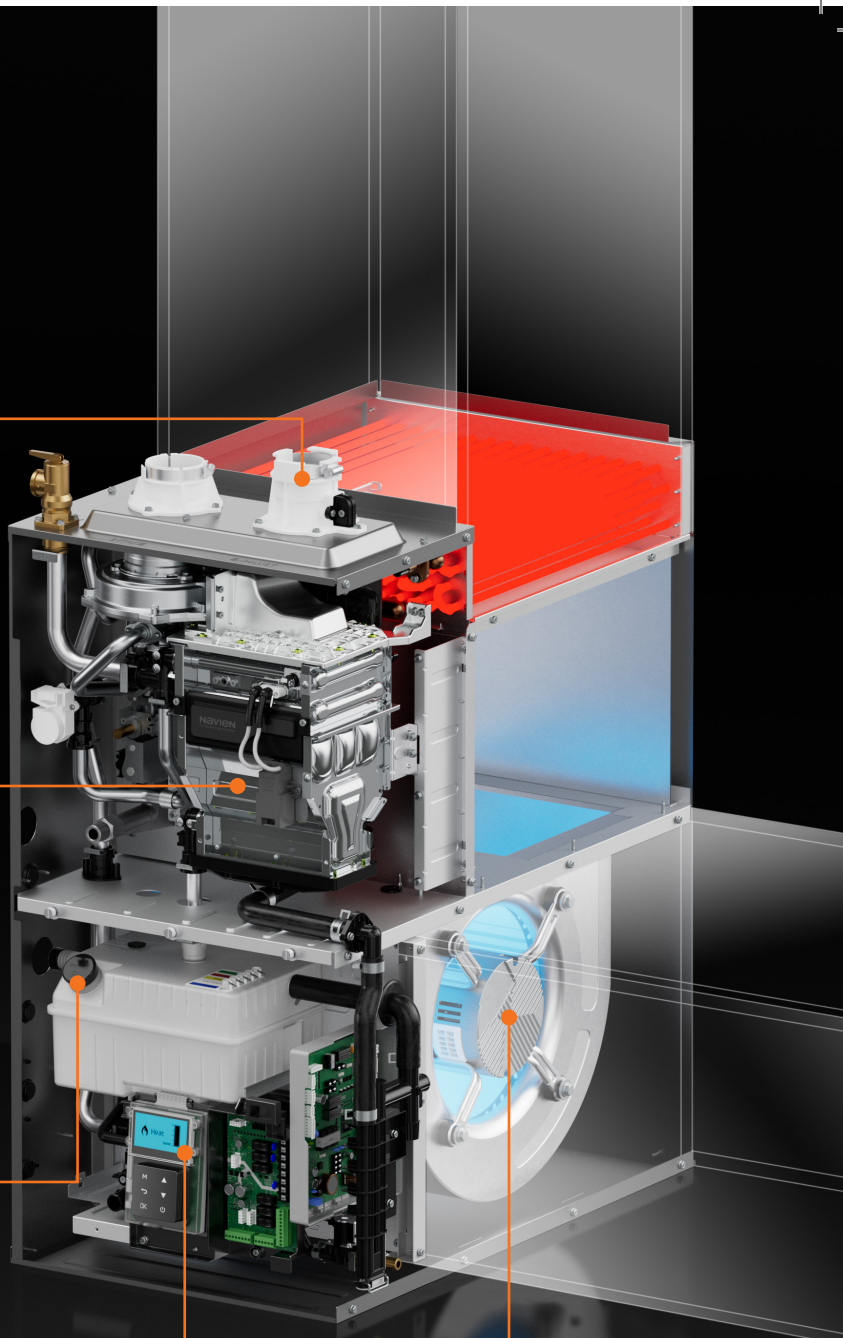

The next level of comfort for your

Quieter

One of the quietest furnaces in the industry is made possible by the isolated heating compartment and variable capacity operation.

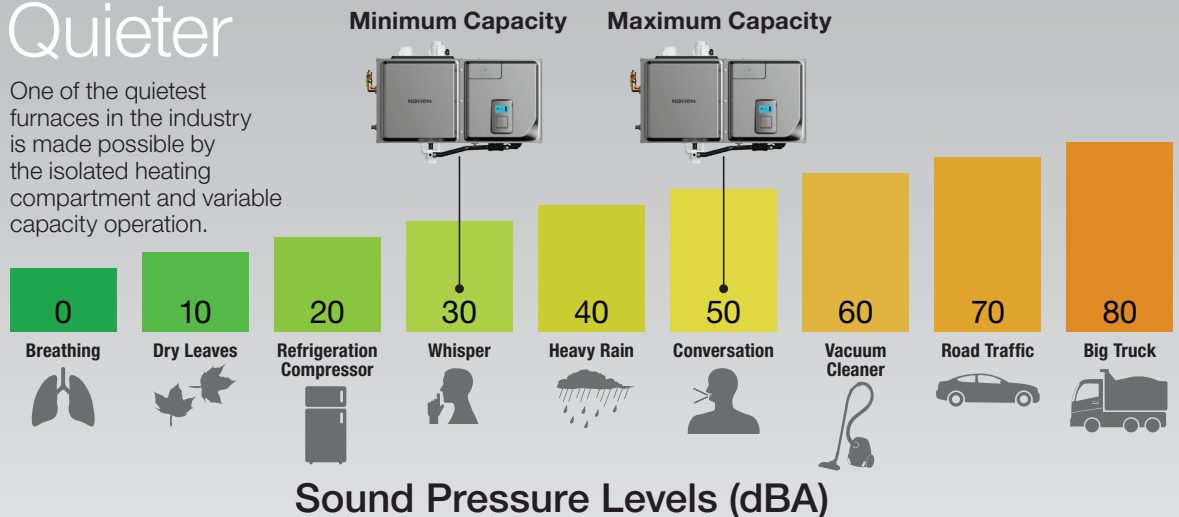

Sound Pressure Levels (dBA)

We test our products in a sound laboratory specifically built to resemble a typical residence. Sound level recordings produced at steady state minimum and maximum operation measured three feet from the furnace. Additional sound level information available at: www.ensafe.com/occupational-noise-exposure-key-osa-provisions.

Easier

The highly efficient NPF not only reduces your energy bills but also offers user-friendly controls and peace of mind with the heat exchanger's lifetime warranty. Simple, a great choice for forced-air heating.



*Limited warranties to original owner in residential applications with prompt registration.

20-year heat exchanger, 5-year parts, and 1-year labor for non-registered furnaces.

Visit Navieninc.com for complete warranty details and restrictions.

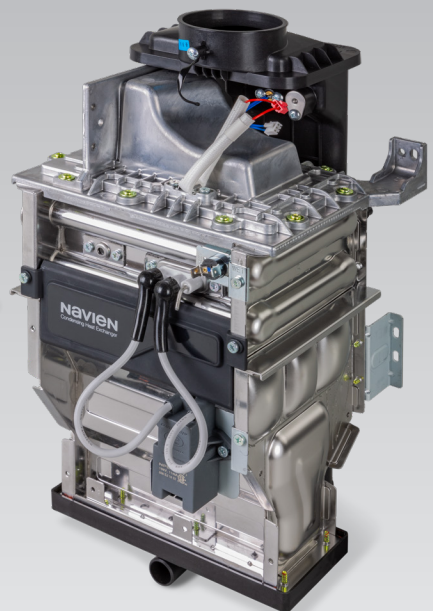

home, family and the environment

Smarter

The NPF's Variable Capacity Control System intelligently adjusts between 15% and 100% capacity to optimize air temperatures and airflow, enhancing both comfort and energy efficiency. Get the full value and comfort of a fully variable furnace while keeping the thermostat you're already familiar with.

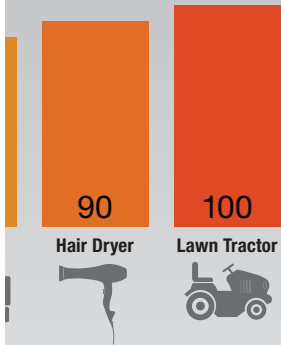
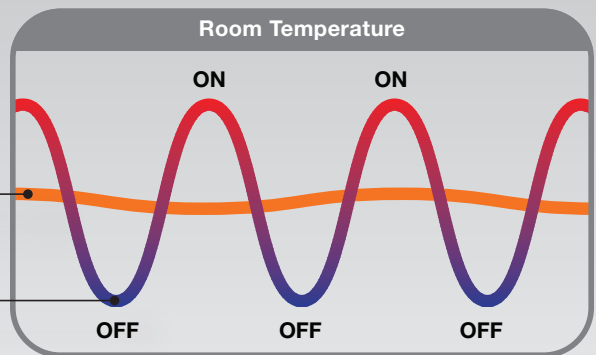

Greener

The NPF is designed with environmental sustainability in mind, boasting a 97% AFUE and Ultra Low NOx compliance. It qualifies for regional incentives, reduces energy bills, and enhances the efficiency of air conditioning and heat pump systems.

97%
AFUE

ULTRA
LowNOx

Complies with
SCAQMD Rule 1111



The ultimate in home heating comfort for all seasons

The NPF Hydro-furnace's Variable Capacity Control System can be configured to precisely adapt air temperatures and airflow to changing outdoor conditions. The result is a wonderfully quiet and gentle flow of hydronic-heated air that truly enhances your home's comfort.

To discover the exceptional comfort the NPF Hydro-furnace can bring to your home, get in touch with your local Navien dealer or visit Navieninc.com.

