

THIS DRAWING IS INTENDED ONLY AS A GUIDE AND NOT AS A REPLACEMENT FOR PROFESSIONALLY ENGINEERED PROJECT DRAWINGS. THIS CONCEPT SYSTEM DRAWING DOES NOT IMPLY COMPLIANCE WITH LOCAL BUILDING CODES. ACTUAL INSTALLATION MAY VARY DEPENDING ON INSTALLATION LOCATION AND PARAMETERS AND IT MUST BE DONE IN ACCORDANCE TO ALL LOCAL BUILDING CODES. VERIFY WITH LOCAL BUILDINGS OFFICIALS BEFORE COMMENCEMENT OF SYSTEM INSTALLATION. CHANGES OR MODIFICATIONS TO PIPING OR DESIGN IS NOT TO BE PERFORMED WITHOUT EXPRESSED WRITTEN PERMISSION BY NAVIEN, INC.

NFB-H UNIT CAN INTERNALLY CONTROL UP TO 3 ZONE CIRCULATORS/ZONE VALVES, WITHOUT A ZONE CONTROL PANEL INSTALLED. ANY ADDITIONAL ZONES SHALL REQUIRE A CIRC ZONE PANEL. REFER TO NAVIEN I & O MANUAL FOR ADDITIONAL INFORMATION.

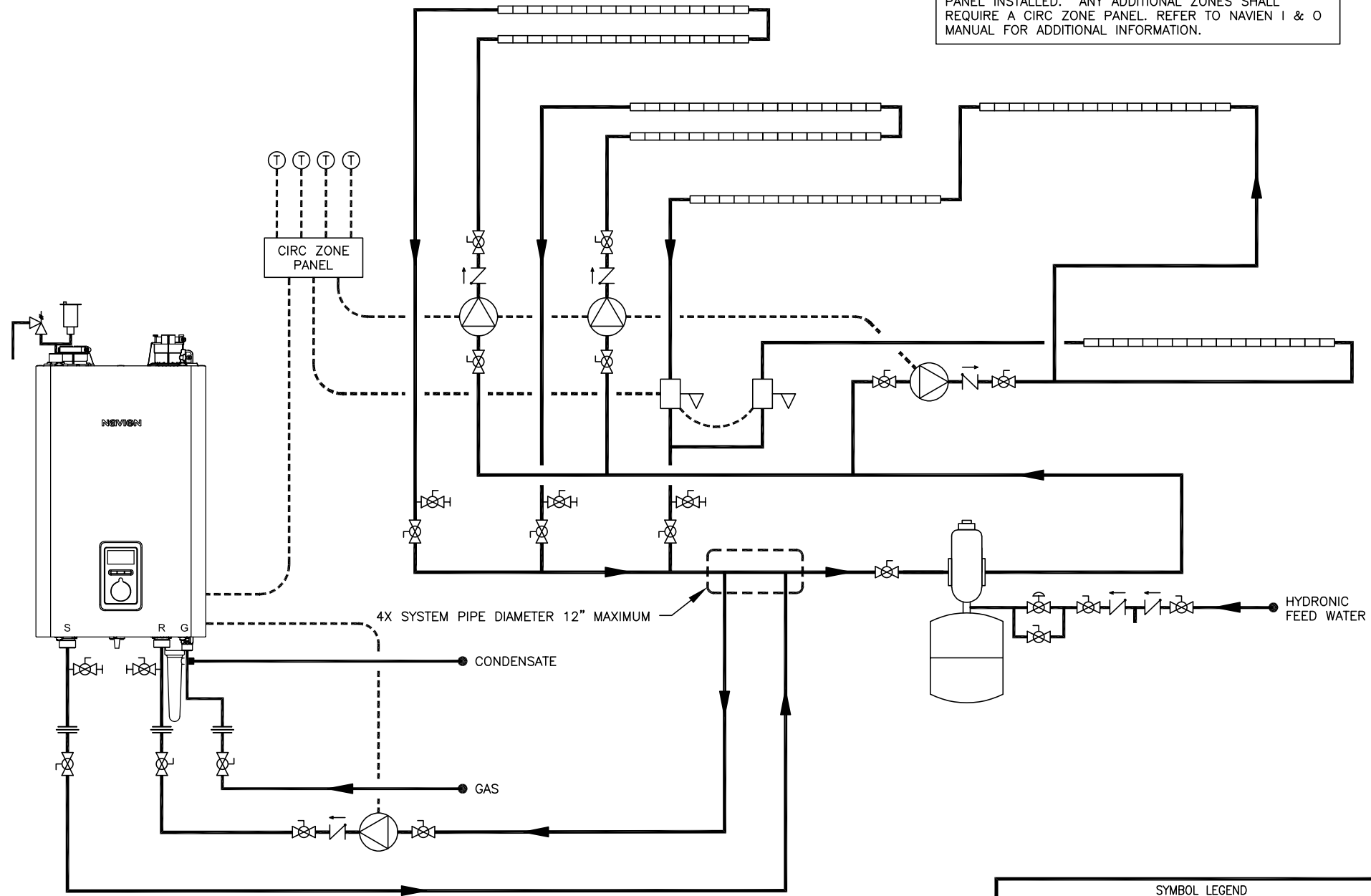

20 GOODYEAR  
IRVINE, CA 92618  
800-519-8794  
www.navienc.com

NFB-H SERIES BOILER

(1) NFB-H BOILER WITH MULTIPLE ZONE CIRCULATORS AND ZONE VALVES  
INCLUDES MODELS NFB-175H, 200H

DRAWN BY:

S. STOEKE

NFB-H-1-2ZP-2ZV

MAY 24, 2022

SYMBOL LEGEND

	BACKFLOW PREVENTER		CHECK VALVE		FULL-PORT VALVE		EXPANSION TANK
	CONTROL WIRING		PRESSURE RELIEF VALVE		CIRCULATOR		THERMOSTAT
	CONDENSATE TRAP		AIR ELIMINATION		UNION		ZONE VALVE
	PRESSURE REDUCING VALVE		AUTOMATIC AIR VENT		COPPER BASEBOARD FIN TUBE		BALL DRAIN VALVE